

GB740

SERIES INSTALLATION TOOL

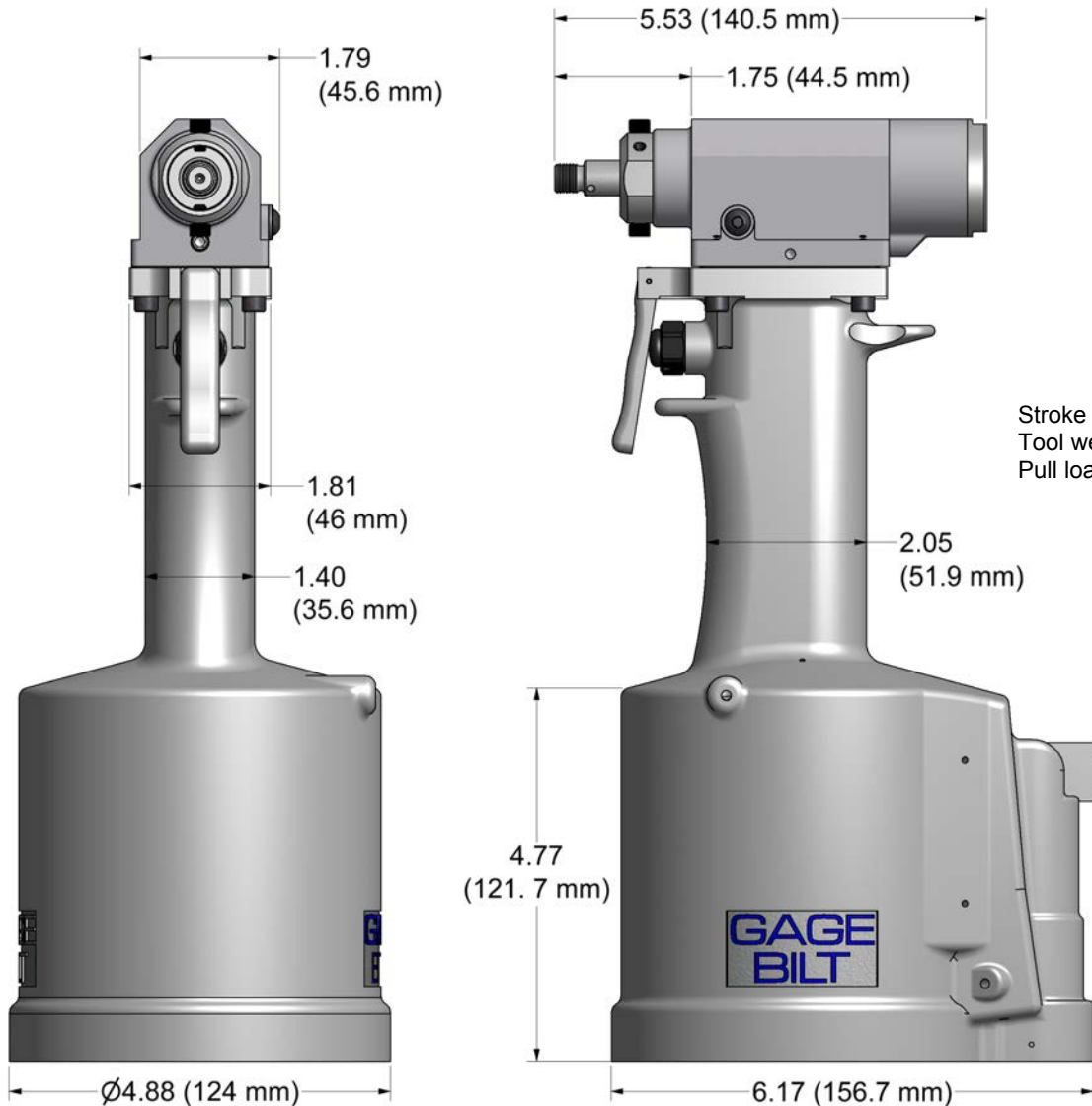

GB740

Stroke - 1.330" (33.78mm)
 Tool weight - 6.50 lbs. (2.9 kg)
 Pull load - 2,400 lbs. (10.7 kN)

DESCRIPTION

The GB740 is a heavy-duty, high speed production tool specifically designed for blind rivets. It weighs only 6.5 lbs. (2.95 kg) and can be operated in any position. With the use of a pneumatic-hydraulic system, it develops a pull load of 2,400 lbs. (10.7 kN) at 90 psi (6.2 bar) and has a 1.330" (33.78 mm) stroke.

The GB740 riveter operates on 90 to 100 psi. (6.2-6.9 bar) of air pressure, with 90 psi (6.2 bar) providing the maximum efficiency. At 90 psi (6.2 bar), the GB740 does not exceed 85 dB(A) and consumes 0.30 SCF/cycle (8.50 L/cycle).

The air inlet is provided with 1/4-18 female pipe thread for accepting the user's air hose fitting.

NOSE ASSEMBLIES ARE NOT FURNISHED WITH TOOL AND MUST BE ORDERED SEPARATELY.

GAGE BILT
 **MADE in USA**



INNOVATIVETOOLING

On the leading edge of Aircraft Tooling

 800-832-7009

 sales@innovativetooling.com

 innovativetooling.com



GB740 Series Installation Tool

ACCESSORIES

Air Bleeder Assy
#704153
(Equivalent to #700A77)
(Sold Separately)



Catcher Bag-Stem
#756610
(Sold Separately)



Catcher Bag-Stem
#704214
(Equivalent to #670A20)
(Sold Separately)



Adapter
#740715

Adapts 715 series nose
assy's to GB740 tool (See
chart).

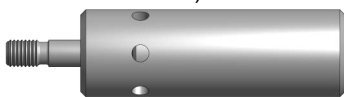

Riveter Kits Available
Contact Gage Bilt to create
your own custom kit.
(Sold Separately)



NOSE ASSEMBLY SELECTION CHART

STRAIGHT
(Sold Separately)

RIGHT ANGLE
(Sold Separately)

OFFSET
(Sold Separately)



FASTENER	DIA.	STRAIGHT	RIGHT ANGLE ^{1,2}	OFFSET ¹
MS20600 SERIES	1/8	4C-740B-52	4C-715A-54RA	4C-715A-40OS
MS/9SP/PT	5/32	5C-740B-52	5C-715A-54RA	5C-715A-40OS
NUT PLATE	3/16	6C-740B-52	6C-715A-54RA	6C-715A-40OS
BACR15CC/CF/DA/DR	1/4	8C-740B-52		
OLYMPIC LOK®	1/8	4A-740B-52	4A-715A-54RA	4A-715A-40OS
BULB LOK®	5/32	5A-740B-52	5A-715A-54RA	5A-715A-40OS
NAS1398A, NAS1399A	3/16	6A-740B-52	6A-715A-54RA	6A-715A-40OS
NAS1738A, NAS1739A	1/4	8A-740B-52		
CHERRYLOCK® 'A'				
CHERRYLOCK®	1/8	4C-640-64		4C-640A-50
NAS1398, NAS 1399 ₃	5/32	5C-640-64		5C-640A-50
NAS1738, NAS 1739 ₄	3/16	6C-640-64		6C-640A-50
	1/4	8C-640-64		8C-640A-50
GROUND STUD				
M83454	8/32	GS8-715B-43 ₁	GS8-715A-54RA	GS8-715A-40OS
BACSS3B1EA1/2				

CHERRYLOCK® IS A REGISTERED TRADEMARK OF CHERRY AEROSPACE. OLYMPIC LOK & BULB LOK® ARE REGISTERED TRADEMARKS OF ALLFAST FASTENING SYSTEMS INC.

GAGE BILT CERTIFIES THE GB740 WILL INSTALL THE ABOVE FASTENERS

1) REQUIRES 740715 ADAPTER.

2) RIGHT ANGLE NOSE ASSEMBLIES MAY REQUIRE MORE THAN 1 PULL.

3) 1/4 DIAMETER ALUMINUM & MONEL® ONLY.

4) THRU 3/16 DIAMETER ONLY.

*ALL COUNTERSUNK 'C' NOSE ASSEMBLIES MAY BE USED TO INSTALL BOTH UNIVERSAL AND COUNTERSUNK HEAD RIVETS.

NOTE: THE LAST 2 DIGITS OF THE NOSE ASSEMBLY REPRESENTS THE LENGTH THE NOSE
EXTENDS FROM THE TOOL. I.E. -52 = 5.2 INCHES

Grip Gage #269G3
(Similar to #269C3)

For CHERRYMAX® and CHERRYLOCK® rivets
(Sold Separately)



Grip Gage #GB105093
(Equivalent to #105093)

For NAS LOCKBOLTS and blind fasteners
(Sold Separately)



Gage Bilt also supplies pin & collar swage
inspection gages to certify swage installation.
(Sold Separately)

