

NOSE ASSEMBLY DATA SHEET

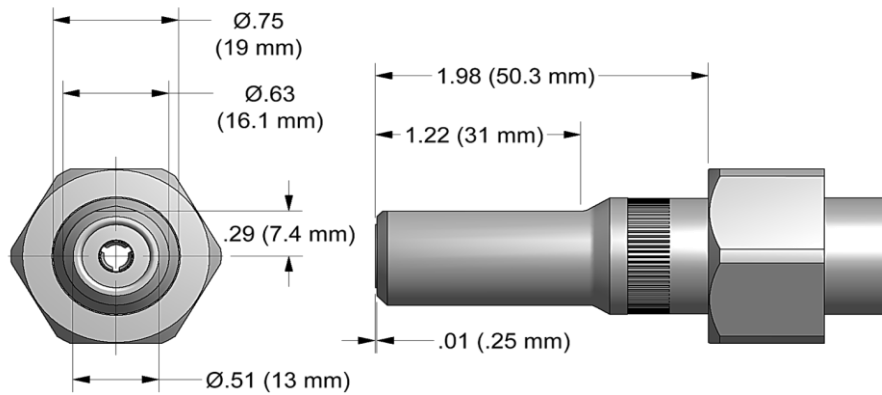

ASSEMBLY:

Note: If nose assy is assembled as it is when purchased new, follow steps 3-5 to attach to tool.

1. Insert super grip jaw assy (4) into rear of collet (3). (Note direction in exploded view).
2. Thread collet (3) to extension-collet (5) using flats provided.
3. Thread assembled collet (3) and extension-collet (5) onto piston of tool using flats provided and hex in rear of piston.
4. Slide anvil & holder assy (2) over collet (3).
5. Slide retaining nut stop and retaining nut over ears on anvil (see exploded view) and tighten to tool.

DISASSEMBLY:

Reverse assembly instructions.

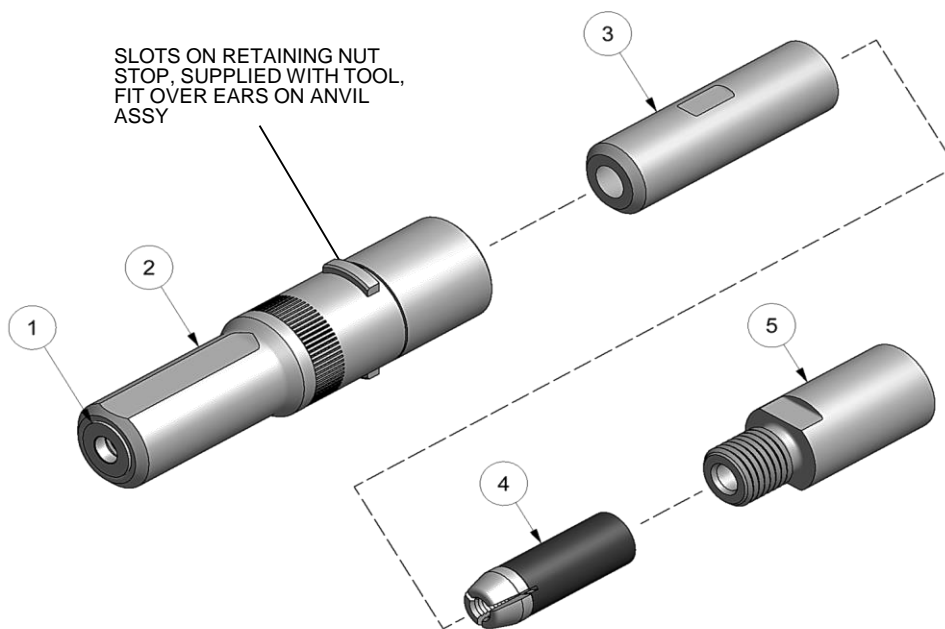

1/02 Rev. 1/18

*Anvil & Holder Assembly consists of #1 and 35208 retainer

GAGE BILT
MADE in USA

INNOVATIVE TOOLING
ON THE LEADING EDGE OF AIRCRAFT TOOLING
Est. 1986 | innovativetooling.com | 800-832-7009

Type:		Fastener:	Recommended Tool:
Non Self-Releasing 1/4" Ø		NAS9301-NAS9312 M7885 BACR15FP/FR BACR15GF/GK	GB722
			Alternate Tools: GB752 & GB2480(A)
Ref. No.	Qty.	Description	08MAX-752B-20
1	1	Anvil-Driving	18009
2	1	*Anvil & Holder Assy (Inc. #1)	17767
3	1	Collet	20717
4	1	Super-Grip Jaw Assy	30864-S
5	1	Extension-Collet	70550