

NOSE ASSEMBLY DATA SHEET

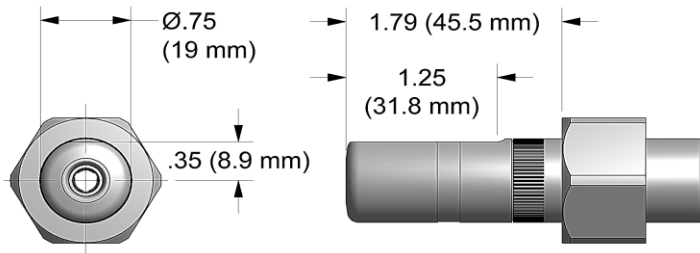

1. Drop jaws #3 into collet #2.
2. Snug extension #4 and collet #2 together using wrench on collet and hex key in rear of extension #4.
3. Thread assembly onto piston and snug with wrench on collet #2 and hex key (provided with tool) into rear of piston.
4. Slide anvil #1 over assembled collet #2 and extension #4.
5. Slide retaining nut stop and nut from tool over anvil #1 and tighten.

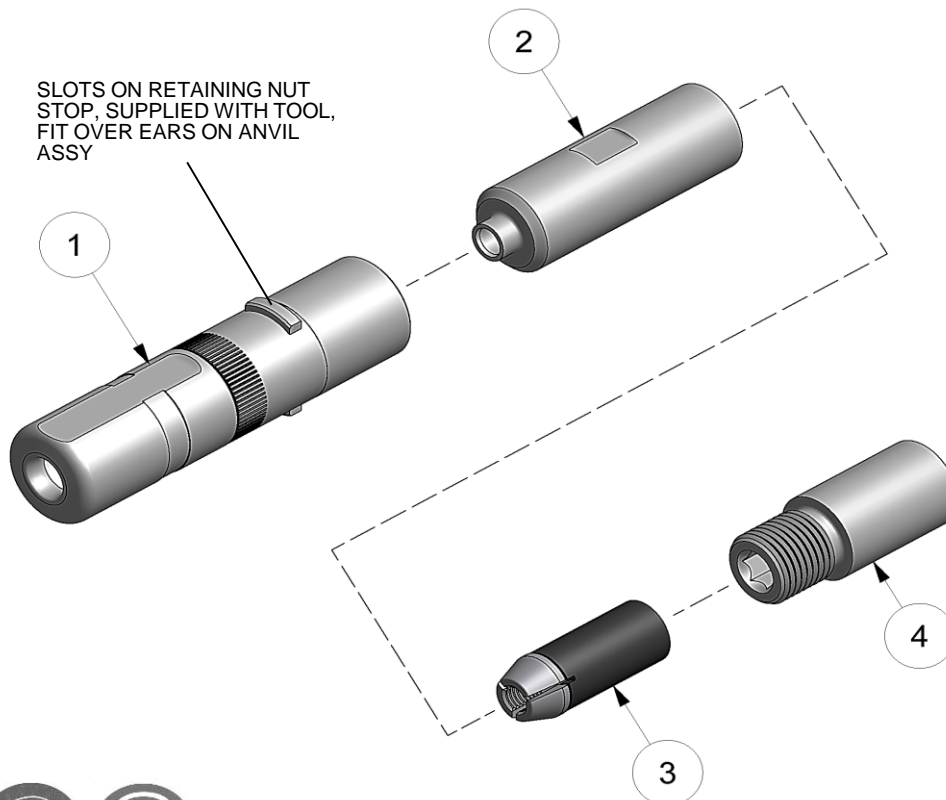

REV 1/16



*Anvil Assembly includes 35208 retainer.

**Yellow band designates nose assemblies for lightweight GP® fasteners.

GAGE BILT INNOVATIVE TOOLING
 ON THE LEADING EDGE OF AIRCRAFT TOOLING
 Est. 1986 | innovativetooling.com | 800-832-7009

Type:		Fasteners:	Recommended Tool: GB731
Non Self-Releasing 7/32" Ø		LGP® Lockbolts	Alternate Tools: GB730 & GB2480(A)
Ref. No.	Qty.	Description	LGP07-731-20
1	1	Anvil Assy	17001
2	1	Collet	20728
3	1	Super-Grip Jaw Assy	30705-CS
4	1	Extension-Collet	70835