

NOSE ASSEMBLY DATA SHEET

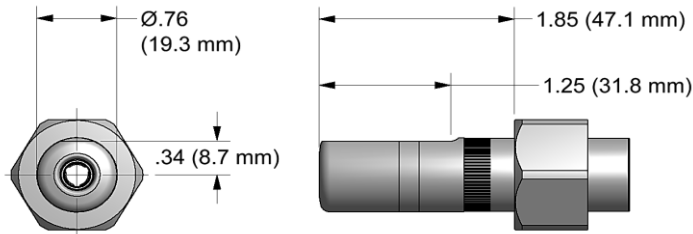

1. Drop jaws #3 into collet #2.
2. Snug extension #4 and collet #2 together using wrench on collet and hex key in rear of extension #4.
3. Thread assembly onto piston and snug with wrench on collet #2 and hex key (provided with tool) into rear of piston.
4. Slide anvil #1 over assembled collet #2 and extension #4.
5. Slide retaining nut stop and nut from tool over anvil #1 and tighten.

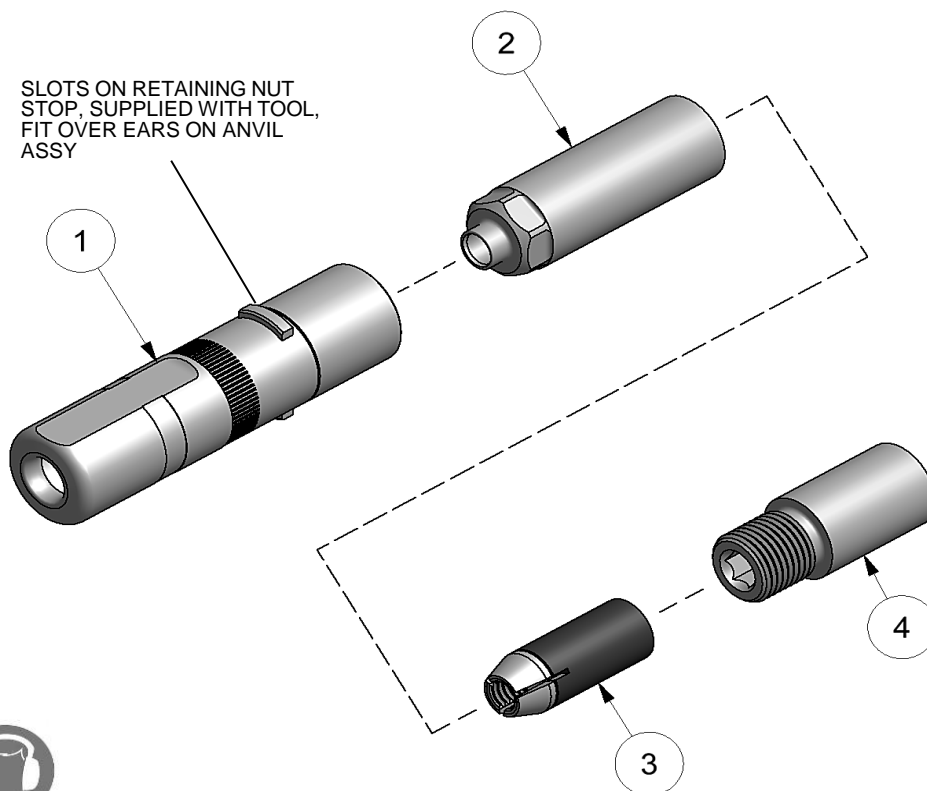

*Anvil Assembly includes 35208 retainer.

**Yellow band designates nose assemblies for lightweight GP® fasteners.

7/15 Rev. 3/17

GAGE BILT **INNOVATIVE TOOLING**
 MADE in USA ON THE LEADING EDGE OF AIRCRAFT TOOLING
 Est. 1986 | innovativetooling.com | 800-832-7009

Type:		Fasteners:	Recommended Tool:
Non Self-Releasing 1/4" Ø		LGP® Lockbolts ASNA2391-4 ASNA2392-4	GB731
			Alternate Tools: GB730 & GB2480(A)
Ref. No.	Qty.	Description	LGP08-2480-20
1	1	Anvil	10891
2	1	Collet	20869
3	1	Super-Grip Jaw Assy	30858-S
4	1	Extension-Collet	70835