

NOSE ASSEMBLY DATA SHEET

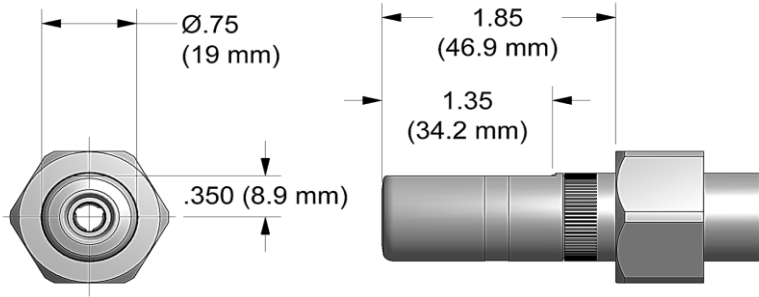

ASSEMBLY:

Notes:

A. Apply Vibra-tite® p/n/ 405125 to all threads and allow it to set 20 minutes prior to assembly.

B. If nose assy is assembled as it is when purchased new, follow steps 3-5 to attach to tool.

1. Insert super grip jaw assy (3) into rear of collet (2). (Note direction in exploded view).
2. Thread collet (2) to extension-collet (4) using hex key in front of collet-extension (4) and flats provided on collet (2).
3. Thread assembled collet (2) and extension-collet (4) onto piston of tool using flats provided and hex in rear of piston.
4. Slide anvil assy (1) over assembled collet (2).
5. Slide retaining nut stop and retaining nut over ears on anvil (see exploded view) and tighten to tool.

DISASSEMBLY:

Reverse assembly instructions.

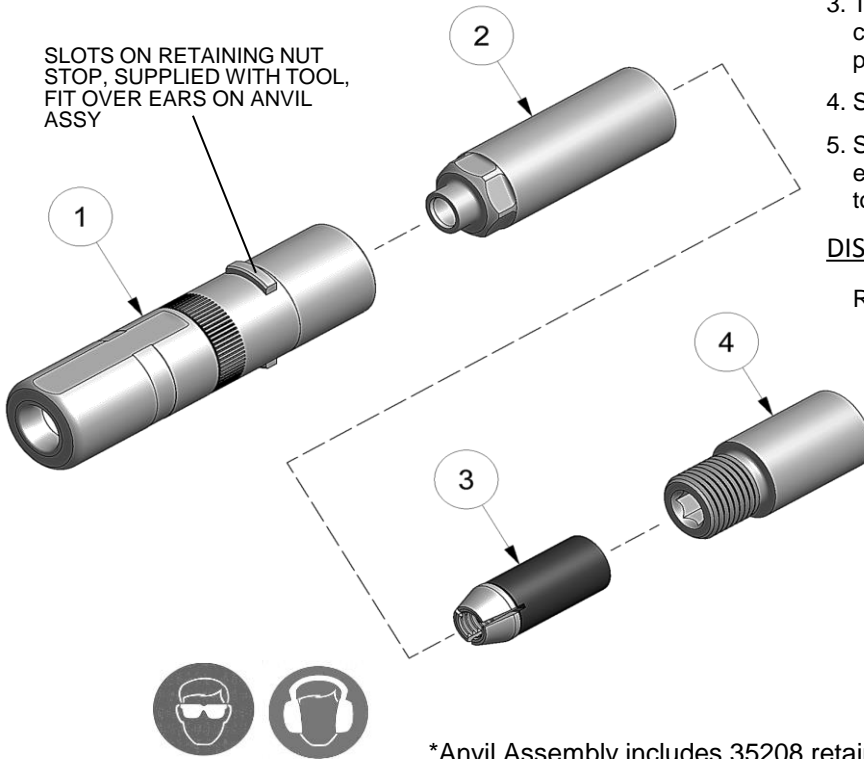

1/18 REV 10/18

*Anvil Assembly includes 35208 retainer.

**Blue band designates nose assemblies for metric GP® fasteners.

GAGE BILT
MADE in USA

INNOVATIVE TOOLING
ON THE LEADING EDGE OF AIRCRAFT TOOLING
Est. 1986 | innovativetooling.com | 800-832-7009

Type:		Fasteners:	Recommended Tool: GB731
Non Self-Releasing 6mm Ø		MGP® Lockbolts	Alternate Tools: GB2480(A)
Ref. No.	Qty.	Description	MGP6-2480-20
1	1	Anvil	16640
2	1	Collet	20666
3	1	Super-Grip Jaw Assy	30858-S
4	1	Extension-Collet	70835