

NOSE ASSEMBLY DATA SHEET

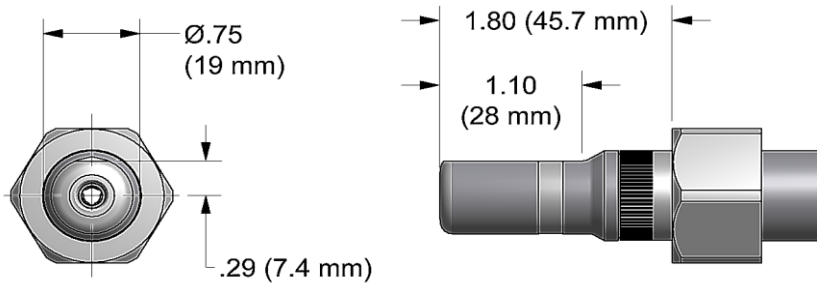

Use Hex-Key in rear of piston for nose assembly attachment.

Use Hex-Key in rear of extension-collet for collet disassembly.

SLOTS ON RETAINING NUT STOP, SUPPLIED WITH TOOL, FIT OVER EARS ON ANVIL ASSY

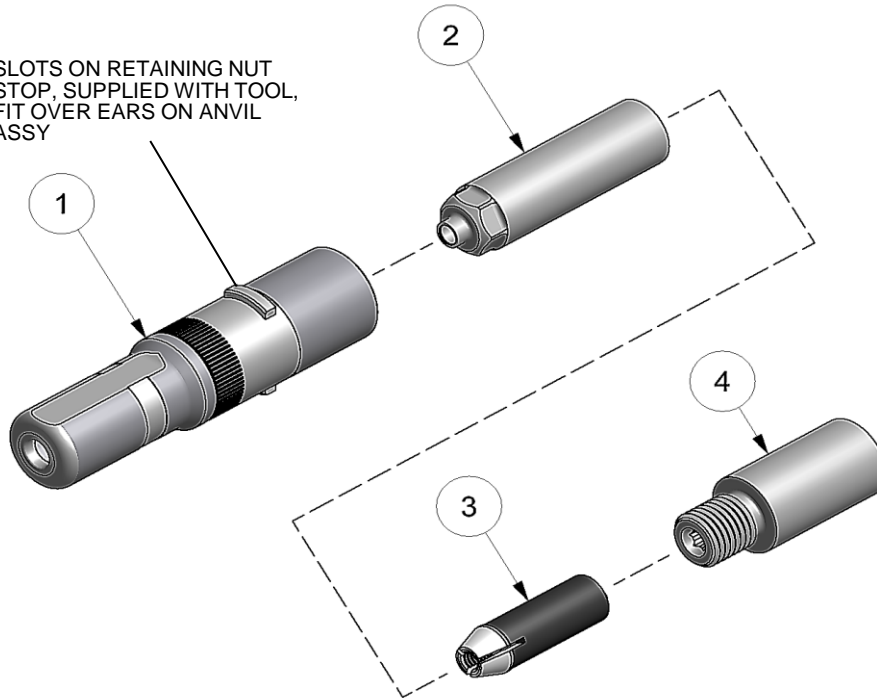

*Anvil Assembly includes 35208 retainer
 **Red band designates nose assemblies for metric lightweight GP® fasteners.

11/15



GAGE BILT **INNOVATIVE TOOLING**
 ON THE LEADING EDGE OF AIRCRAFT TOOLING
 Est. 1986 | innovativetooling.com | 800-832-7009

Type:		Fastener:	Recommended Tool:
Non Self-Releasing 4mm Ø		MLGP® Lockbolts	GB731
			Alternate Tools: GBP2480
Ref. No.	Qty.	Description	MLGP4-2480-20
1	1	Anvil Assy	10451
2	1	Collet	20537
3	1	Super Grip Jaw Ass'y	30542-S
4	1	Extension-Collet	70550