

NOSE ASSEMBLY DATA SHEET

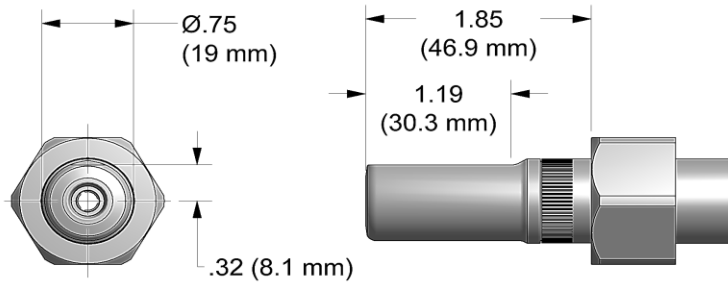

ASSEMBLY:

Note: If nose assy is assembled as it is when purchased new, follow steps 3-5 to attach to tool.

1. Insert super grip jaw assy (3) into rear of collet (2). (Note direction in exploded view).
2. Thread collet (2) to extension-collet (4) using flats provided .
3. Thread assembled collet (2) and extension-collet (4) onto piston of tool using flats provided and hex in rear of piston.
4. Slide anvil & holder assy (1) over collet (2).
5. Slide retaining nut stop and retaining nut over ears on anvil (see exploded view) and tighten to tool.

DISASSEMBLY:

Reverse assembly instructions.

Slots on retaining nut stop, supplied with tool, fit over ears on anvil assembly

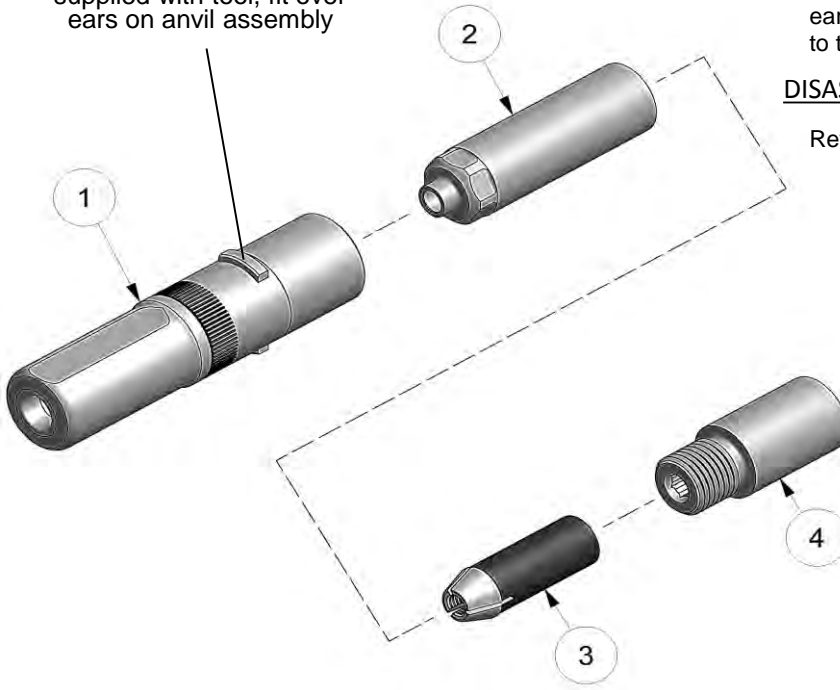

3/16 REV 9/17

*Anvil Assembly includes 35208 retainer.

GAGE BILT INNOVATIVE TOOLING
 ON THE LEADING EDGE OF AIRCRAFT TOOLING
 Est. 1986 | innovativetooling.com | 800-832-7009

MADE in USA

Type:		Fasteners:	Recommended Tool: GB731
Non Self-Releasing 3/16" Ø		NAS Shear and NAS Tension Pull Type Lockbolts, C6L® & GP® Lockbolts	Alternate Tools: GB730 & GB2480(A)
Ref. No.	Qty.	Description	NAS06-2480-20
1	1	Anvil Assy	16601
2	1	Collet	20569
3	1	Super-Grip Jaw Assy	30651-S
4	1	Extension-Collet	70636