

# NOSE ASSEMBLY DATA SHEET

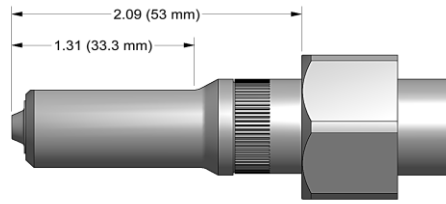

SLOTS ON RETAINING NUT STOP, SUPPLIED WITH TOOL, FIT OVER EARS ON ANVIL ASSY

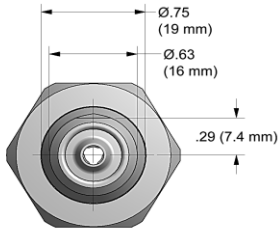
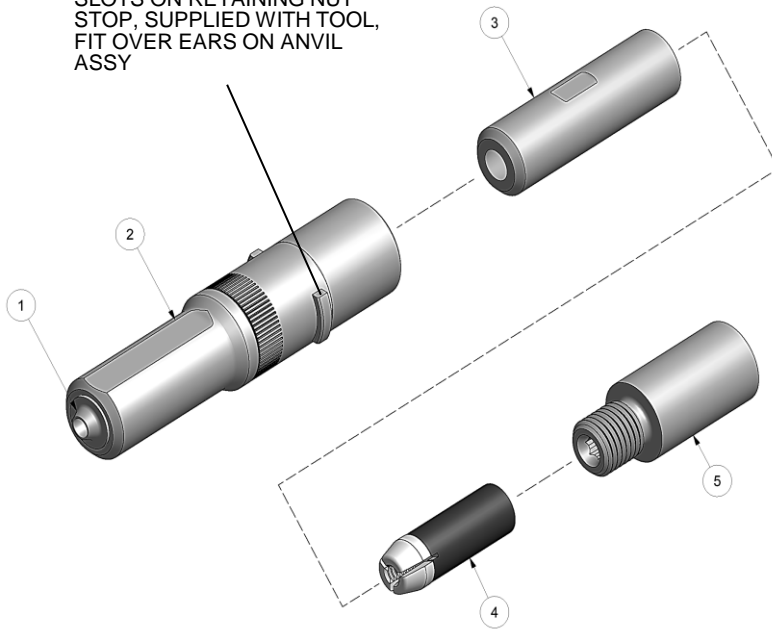

## ASSEMBLY:

### Notes:

- A. Apply Vibra-tite® p/n/ 405125 to all threads and allow it to set 20 minutes prior to assembly.
  - B. If nose assy is assembled as it is when purchased new, follow steps 3-5 to attach to tool.
1. Insert super grip jaw assy (4) into collet (3).
  2. Snug tighten assembled collet (3) to collet-extension (5) using flats on collet (3) and hex in extension-collet (5).
  3. Tighten assembly to piston on tool using flats provided.
  4. Slide anvil (2) over assembled collet (3).
  5. Slide retaining nut stop (see note in exploded view) and retaining nut over anvil (2) and tighten nose assembly to tool.

## DISASSEMBLY:

Reverse assembly instructions.



Rev. 10/18

\*Anvil Assembly includes 35208 retainer.

**GAGE BILT**  
MADE in USA

**INNOVATIVE TOOLING**  
ON THE LEADING EDGE OF AIRCRAFT TOOLING  
Est. 1986 | [innovativetooling.com](http://innovativetooling.com) | 800-832-7009

Type:		Fasteners:	Recommended Tool: <b>GB752</b>
Non Self-Releasing 3/16" Ø		<b>BLIND BOLT (SINGLE ACTION) WITH OR W/OUT DRIVE WASHER</b> MS90353S & U / MS90354S & U MS21140S & U / MS21141S & U MAXI-BOLT®, BACB30YY, YU, & YT	Alternate Tools: GB713, GB722 & GB2480(A)
Ref. No.	Qty.	Description	<b>SB06-752B-20</b>
1	1	Anvil-Driving	16024
2	1	Anvil & Holder Assy (Includes #1)	17744
3	1	Collet	20717
4	1	Super-Grip Jaw Assy	30655-S
5	1	Extension-Collet	70550