

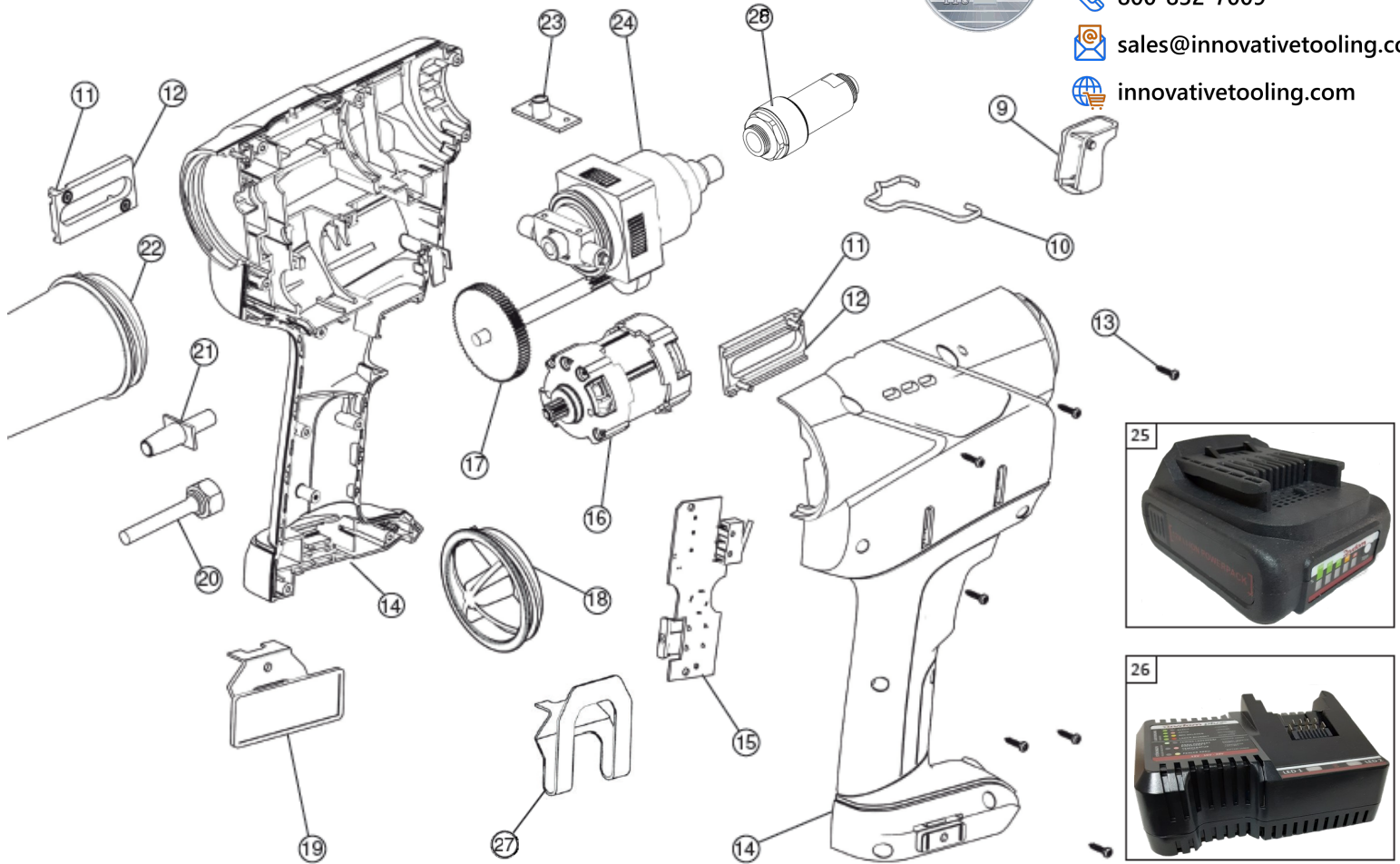

## GB110AOS PARTS LIST



REF NO.	PART NO.	DESCRIPTION	QTY.
9	VP1316	TRIGGER AND PRESSURE SPRING	1
10	VP1317	HANGER	1
11	VP1007	SCREW FOR BEARING (2 PIECES)	1
12	VP1285	GEAR BOX BEARING	1
13	VP1011	HOUSING SCREWS (1 SET = 10 PIECES)	1
14	VP1346	HOUSING (LEFT AND RIGHT)	1
15	VP1615	ELECTRONIC ASSEMBLY COMPLETE	1
16	VP1348	MOTOR	1
17	VP1349	PINION SHAFT ASSEMBLY	1
18	VP1321	COVER CAP	1
19*	VP1323	NAME PLATE	1
20	VP1387	MANDREL DISCHARGE TUBE	1
21	VP1351	PLASTIC TUBE	1
22a	VP1002	MANDREL CONTAINER L (8.0 CM)	1
22b*	VP1356	MANDREL CONTAINER L+ (8.0 CM)	1
22c*	VP1425	MANDREL CONTAINER XL+ (11.0 CM)	1
23	VP1004	MAGNET HOLDER WITH MAGNET	1

REF NO.	PART NO.	DESCRIPTION	QTY.
24	VP1352	GEAR BOX COMPLETE	1
25a	VP1086	Li-Ion BATTERY 20V / 2.0 Ahh	2
25b*	VP1357	Li-Ion BATTERY 20V / 4.0 Ahh	2
26	VP1087	UNIVERSAL QUICK CHARGER 110V	1
27	VP1322	BELT CLIP	1
28**	110206	ADAPTER-ROTATABLE	1
28a**	756262	SPLIT RING	1
28b**	400787	O'RING	1
28c**	756263	RETAINING SLEEVE	1
28d**	110210	ADAPTER ANVIL-OFFSET	1
28e**	110211	EXTENSION ADAPTER-DRAWBAR	1
28f**	110212	ADAPTER ASSEMBLY-DRAWBAR	1
28g**	110213	ADAPTER NOSE-TOOL SIDE	1
28h**	408423	RETAINING RING	1
28i**	731244	CAP-DRAWBAR ADAPTER	1
NO FIG	VP1327	SCREW FOR ELEC. ASSEMBLY	1

\* Sold Separately

GB110AOS/2-4Ah SHOWN ABOVE

\*\*Adapter-Rotatable (110206) (28) includes: 756262 (28a), 400787 (28b), 756263 (28c), 110210 (28d), 110211 (28e), 110212 (28f), 110213 (28g), 404423 (28h) & 731244 (28i).

Apply blue Loctite® #242 to threads of piston on tool and on male threads of extension adapter nose-tool side (110213) before installation.

GB110AOS SERIES	
GB110AOS	Includes (1) VP1086 (2Ah Battery)
GB110AOS/2	Includes (2) VP1086 (2Ah Batteries)
GB110AOS-4AH	Includes (1) VP1357 (4Ah Battery)
GB110AOS/2-4AH	Includes (2) VP1357 (4Ah Batteries)

