



## **BP7000** AIR-HYDRAULIC POWER UNIT MAINTENANCE HANDBOOK



**INNOVATIVE TOOLING**  
ON THE LEADING EDGE OF AIRCRAFT TOOLING  
Est. 1986 | [innovativetooling.com](http://innovativetooling.com) | 800-832-7009

## **SECTION 1: INTRODUCTION**

### **1-1 SERVICE POLICY**

Handbook provides maintenance and care instructions that are recommended for your BP7000 Power Unit. Power Unit was designed and built to first class standards in workmanship and materials. The routine maintenance, proper care, and use of this Power Unit will increase the life of your equipment. Please follow routine maintenance intervals.

### **1-2 REPAIRS**

Repairs should be performed by a trained professional. Please contact our customer service department for assistance and support with servicing or repairs of this Power Unit.

### **1-3 WARRANTY**

HS Tooling/U.S. Industrial Tool Co. provides a limited warranty and will cover all manufacturing defects of materials or parts within one (1) calendar year from the date of shipment of the Power Unit. All warranty claims will require a return authorization number (RMA) from our customer service department before any units are returned for evaluation. Warranty does not cover defective units caused by operator error or misuse of equipment, attempts to repair or modification of the Power Unit to the model designed purchased or any negligence or damage due to improper use of the power unit. U.S. Industrial Tool Co. reserves the right to review all claims made against the considered unit.

Note: All units that are not traceable back to U.S. Industrial Tool Co. Tool via assigned tool serial number will not be covered under our specified warranty.

# 1

## INTRODUCTION



### 1-4 POWER UNIT, GUN AND DRIVING TOOLS

A. The B7250 POWER UNIT and GUN is comprised of the BP7000 Air-Hydraulic Power Unit, the BG2500 Gun, and the BK4 Tool Kit. The BK7 Tool Kit may be substituted for the BK4 on request. BK8 Tool Kit may be ordered at additional cost. See Table 2 for contents of kits.

	B7250 Complete Installation Unit
Overall Length	39-5/8"
Overall Width	17-1/2"
Overall Height	25-1/2"
Weight of Power Unit & Gun	83.5 lbs.

**TABLE 1. LEADING PARTICULARS - POWER UNIT**

- B. BP7000 POWER UNIT uses compressed air to operate the pump which in turn supplies hydraulic pressure to actuate the BG2500 Gun. See Figure 1.
- C. BG2500-22251 gun is a modified version of the BG2500 Gun and installs Blind Bolt diameter sizes -5 (5/32) thru - 10 (5/16) and Blind Nut sizes - 440 (4-40) thru - 1032 (10-32). See Figure 2.
- D. BG2500 Gun installs HS Tooling fasteners up to 1/2". It is recommended for use on Blind Bolts in sizes -8 (1/4) and larger, and Blind Nuts in size -832 (8-32) and larger. The gun can drive all smaller size fasteners, but because of its low pressure settings operates with relative slow action in the smaller sizes. See Figure 2.
- E. A set of DRIVING TOOLS - a Mandrel, Chuck and Anvil -- are assembled on the nose of the gun to install a specific type and size of fastener. If another type fastener is encountered, it requires a matching size of Driving Tools. Sets of Blind Bolt or Blind Nut Driving Tools are furnished with each Power Unit and Gun combination.
- F. Refer to Publication 2-1033, "Blind Bolt and Blind Nut Brochure", for ordering information on Power Units, Guns, and Driving Tools.

\* Conversion kit #22251 is to convert BG2500 gun to BG2500-22251 and is available \*

**TOOLING FOR BG2500 AND BG2500-22251 IS IDENTICAL**

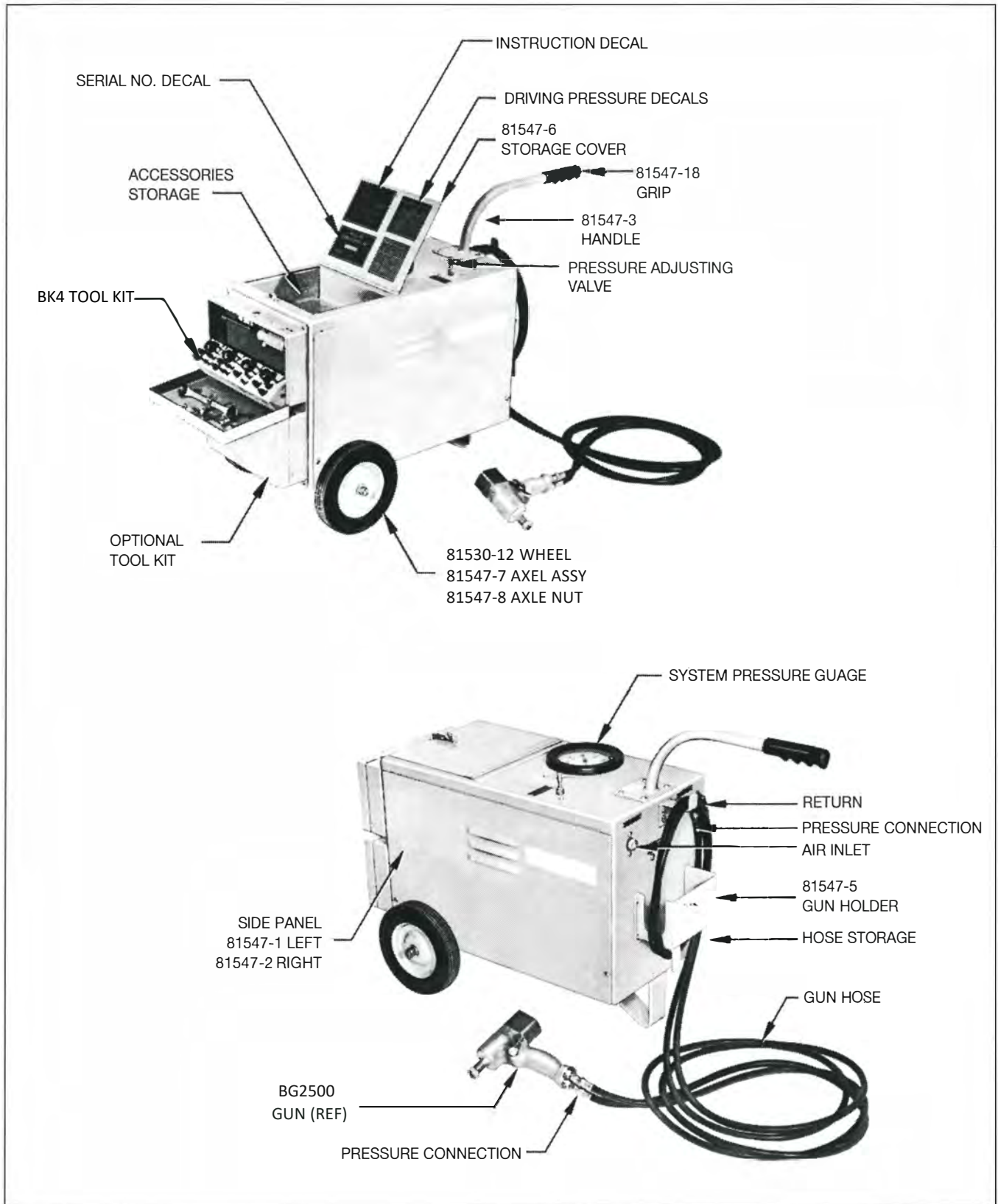

**FIGURE 1. B7250 POWER UNIT SHOWN WITH BG2500 GUN**

# 1

## INTRODUCTION

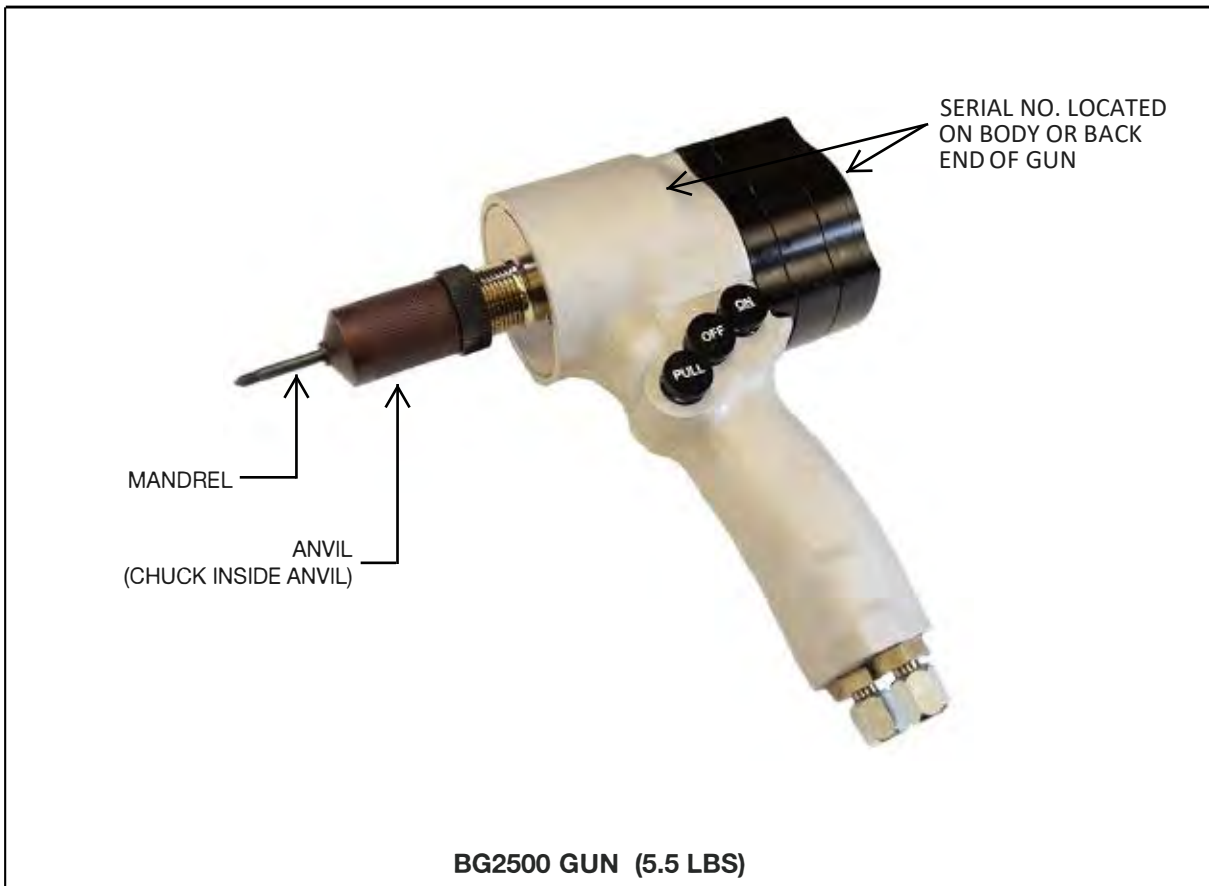

FIGURE 2. GUNS TO INSTALL HI-SHEAR FASTENERS



**FIGURE 3. TYPICAL BK (BLIND BOLT OR BLIND NUT) SERIES TOOL KIT  
(SEE TABLE 2 FOR CONTENTS)**

# 1

## INTRODUCTION



### Blind Bolt™ and Blind Nut™ Tool Kits

Contents of BK4 Took Kit for use with the BG2500 Gun. Quantites in ( ).

BB351, BB352					
BB365, BB366, Blind Bolt					
Bolt First Dash No.	Anvil	Chuck	Mandrel	Core Bolt Driver	Other
-5	A21-5(1)	C2-5(2)	M1-5(4)	440-1 Phillips #1(4)	Open End Wrench
-6	A21-6(1)	C2-6(2)	M1-6(3)	440-F Frearson (4)	3/8, 7/16 (1)
-8	A21-8(1)	C2-8(1)	M1-8(2)	440-2 Phillips #2(2)	T-Handle, 1/4" Drive(1)
-10	*A21-10(1)	C2-10(1)	M1-10(1)	HTS3 Hi-Torque(2)	T-Handle, 3/8" Drive(1)
-12	A21-12(1)	C2-12(1)	M1-12 (1)	HTS4A Hi-Torque(2)	Screwdriver(1)

Contents of BK7 Took Kit for use with the BG2500 Gun (may be substituted for BK4). Quantites in ( ).

BB360, BB372					
Blind Nut					
First Dash No.	Anvil	Chuck	Mandrel	Core Bolt Driver	Other
-440	A27-440(1)	C2-5(2)	M1-5(4)		Open End Wrench
-632	A27-632(1)	C2-632(2)	M1-632 (3)		3/8, 7/16 (1)
-832	*A25-832(1) - A27-832(1)	C2-8 (1)	M1-8(2)		
-1032	*A25-1032(1) A27-1032(1)	C2-1032(1)	M1-1032(1)		
-428	*A25-428 (1) A27-428(1)	C2-12(1)	M1-12(1)		

Contents of BK8 Took Kit for use with the BG2500 Gun (available at additional cost). Quantites in ( ).

88351, 88352					
88365, 88366, Blind Bolt					
Bolt First Dash No.	Anvil	Chuck	Mandrel	Core Bolt Driver	Other
-12	A21-12(1)	C2-12(2)	M1-12(2)	HTS4A(1)	Open End Wrench
-14	A21-14 (1)	C2-14(1)	M1-14 (1)	HTS5(1)	3/8, 7/16(1)
-16	A21-16 (1)	C2-16(2)	M1-16(2)	HTS6(1)	T-Handle, 3/8" Drive (1)
BB360, BB372					
Blind Nut					
First Dash No.	Anvil	Chuck	Mandrel	Core Bolt Driver	Other
-428	*A25-428 (1) A27-428(1)	Use Chucks	Use Mandrels		
-524	A257524 (1) *A27-524(1)	Listed Above	Listed Above		
-624	*A25-624(1) A27-624(1)				
-720	A27-720(1)		M1-720 (1)		
-820	*A27-820(1)	C3(2)	M1-820(1)		

All kits are packaged in metal boxes which attach to the end of the Power Unit.

\* T these tools are for BN359 Blind Nuts.

**TABLE 2. BK TOOL KITS (CONTENTS)**

## **SECTION 2: OPERATION**

### **2-1 GENERAL**

BP7000 Power Unit is a precision piece of hydraulic equipment. U.S. Industrial recommends that all services and repairs be done by trained personnel. For additional assistance, please contact our customer service department.

### **2-2 PRELIMINARY SERVICE**

- A. Remove Power Unit from shipping container.
- B. Remove handle from inside Power Unit (shipping storage). Attach with furnished screws (see Figure 5).
- C. Remove shipping plug from filler neck on top of reservoir. Replace with furnished breather cap/dip stick assembly.

**\*\*\* PLEASE NOTE: IMPORTANT - CAUTION \*\*\***

THIS POWER UNIT IS SHIPPED WITHOUT OIL IN THE RESERVOIR. PLEASE MAKE SURE TO ADD OIL BEFORE STARTING THE UNIT.

U.S. INDUSTRIAL TOOL DOES NOT TAKE RESPONSIBILITY FOR DAMAGE TO UNITS CAUSED BY OPERATING UNIT WITHOUT OIL.

The following oil types are recommended for operation:

MIL-H-6083

MIL-H-5606



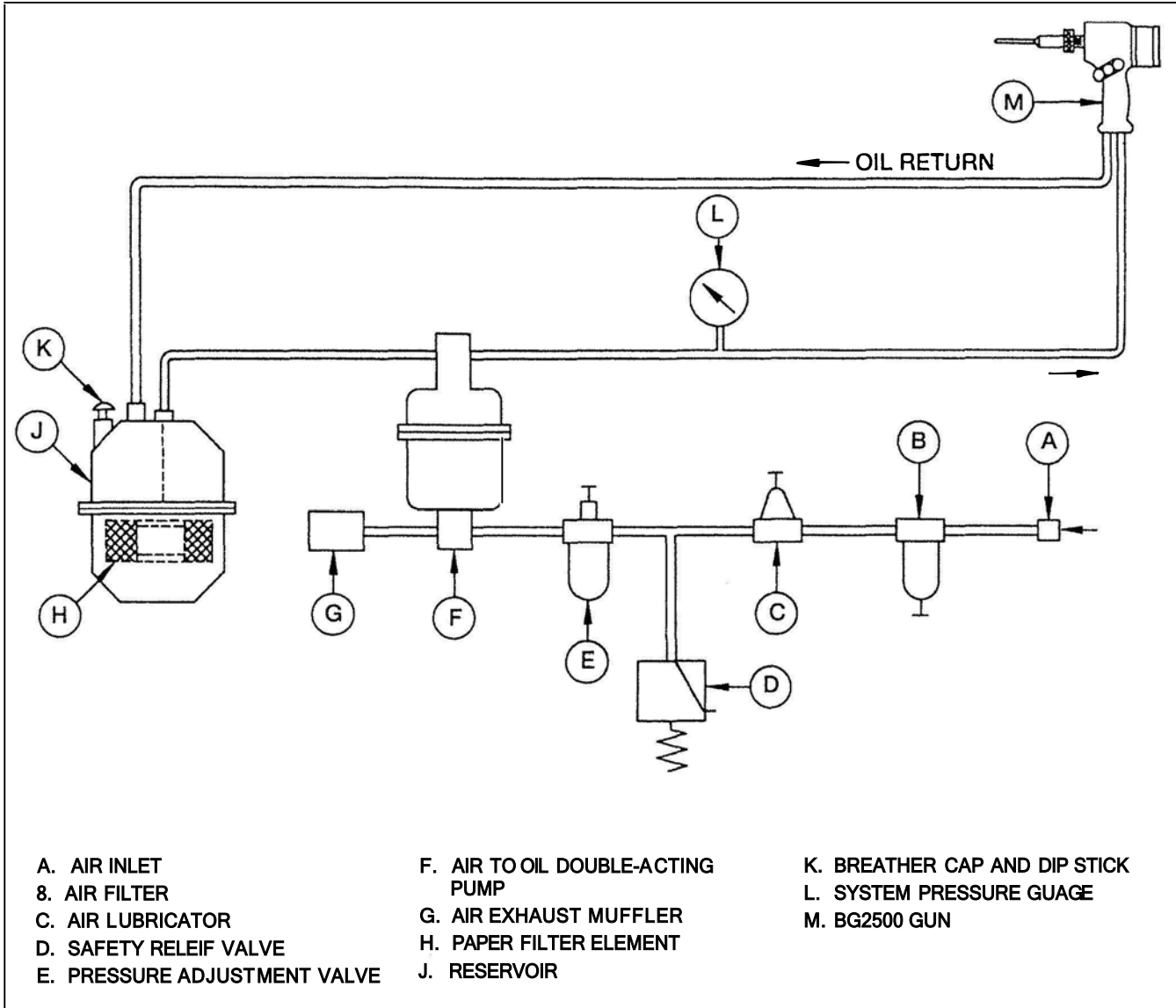

FIGURE 4. BP7000 AIR-HYDRAULIC POWER UNIT SCHEMATIC

**2-3 STARTING THE POWER UNIT**

**WARNING**

Do not operate this unit over 2500 psi.

- A. Connect the factory air supply to the Power Unit air inlet (3/8 female pipe thread). For maximum efficiency, the air supply line should have the same or larger inside diameter as the air inlet. Installation of a pressure regulator is recommended at the connection. Normal factory air pressure (at least 90 psi) is sufficient to drive all sizes of HS Tooling fasteners.

**CAUTION**

The air lubricator's oil level, located on the air supply side of the pump, must be checked and maintained. A light machine oil is recommended.

- B. Select from driving pressure based on the driving pressure tables (Table 3) relative to the size and type of fastener to be driven for the BG2500 Gun.
- C. Turn the "Pressure Adjusting Valve" until the desired pressure is indicated on the pressure gauge dial (clockwise to increase pressure, counterclockwise to decrease pressure). Unit is now ready for fastener installation.
- D. At completion of operation (if unit is to be out of use for an extended period of time), relieve pressure by turning the "Pressure Adjusting Valve" counterclockwise.
- E. The Power Unit is equipped with a safety relief valve to limit the pump system pressure to 2800 psi.

Blind Bolt Size	Blind Nut Size	BG2500-22251 Gun	BG2500 Gun
-5 (5/32)	-440 (4-40)	500 psi	250 psi
-6 (3/16)	--	700 psi	350 psi
	-632 (6-23)	800 psi	400 psi
-8(1/4)	-832 (8-32)	1100 psi	650 psi
-10 (5/16)	-1032 (10-32)	1850 psi	950 psi
-12(3/8)	-428(1/4-28)		1450 psi
-14(7/16)	-524 (5/16-24)		1900 psi
-16(1/2)	-624 (3/8-24)		2250 psi
-720	-720 (7/16-20)		2250 psi
-820	-820 (1/2-20)		2250 psi

**TABLE 3. SYSTEM DRIVING PRESSURES FOR BLIND BOLTS AND BLIND NUTS**

# 2

# OPERATION



## 2-3 STARTING THE POWER UNIT (continued)

P-Nut Size	BG2500-22251 Gun		BG2500 Gun	
	7075-T6 Aluminum	Mild Steel (Rockwell - A Scale 43)	7075-T6 Aluminum	Mild Steel (Rockwell-A Scale 43)
-632	1000 psi	750 psi	540 psi	440 psi
-832	1450 psi	900 psi	760 psi	580 psi
-1032	1900 psi	1550 psi	980 psi	820 psi
-428			1400 psi	1050 psi
-524			1660 psi	1410 psi
-624			1860 psi	1740 psi

**TABLE 4. SYSTEM DRIVING PRESSURES FOR P-NUTS**

Blind Press Nuts	BG2500 Gun
-1032 (10-32)	700 psi
-428 (1/4-28)	1000 psi
-528 (5/16-28)	1500 psi
-624 (3/8-24)	1800 psi

**TABLE 5. SYSTEM DRIVING PRESSURES FOR BLIND PRESS NUTS**

## 2-4 STOPPING THE POWER UNIT

A. Shut off air supply to stop pump.

B. Turn Pressure Adjusting Valve counterclockwise until pressure is relieved. (Skip is unit is only to be temporarily shut off and if the same driving pressure is to be continued.)

**3****SERVICE****3-3 TROUBLESHOOTING - POWER UNIT**

TROUBLE	PROBABLE CAUSE	REMEDY
A. Power Unit is overheating.	Results from lack of normal oil circulation or because of sustained or continuous usage at high driving pressures.	Do not operate the Power Unit at continuous high pressure when not in use. Reduce air pressure or stop unit during employee rest or lunch hours or at the end of a day's work.
B. Excessive popping noise.	Probably leak in pump air exhaust.	Check air line from pump to air exhaust muffler for leakage or loose connection.
C. System pressure does not build up when pump appears to be operating.	Full oil circulation through system requires a minute or two to build up pressure before Gun can be used.	When starting air pump, turn Pressure Adjusting Valve several turns clockwise and wait for gauge to indicate a pressure rise before setting system driving pressure.
	Insufficient oil in system.	Replenish oil in reservoir.
	Gun Control Button stuck in depressed position.	Remove Gun Slide Valve and clean.
	Leakage in Power Unit's hydraulic system.	Check Power Unit for visible leakage in plumbing or hose connection
		Determine if leakage is in Gun. Disconnect hose from Gun and then cap hose to seal. Operate Power Unit at selected driving pressure, and if pressure remains stable, the leakage is in the Gun.
		If leakage is in Power Unit, check the Safety Relief Valve which may be set too low. Reset to 2800 psi.

## **SECTION 4: OVERHAUL**

### **4-1 GENERAL INSTRUCTIONS POWER UNIT**

- A. All service or repair work should be done **ONLY BY A MECHANIC WHO IS WELL-QUALIFIED IN HYDRAULIC SPECIFICATIONS AND TECHNIQUES.**
- B. During disassembly of Power Unit or components, cap all lines and fittings to prevent dirt from entering system.
- C. Clean all parts as follows:
  - 1. Immerse and wash all hydraulic metallic parts in solvent (Federal Specification P-S-661 or equivalent). Give special attention to internal areas and threads.
  - 2. Dry the metallic parts by compressed air or evaporation only.
  - 3. Clean the O-rings and seals in hydraulic oil. Leave in oil until reassembly. Do not dry.
- D. Inspect component parts as follows:
  - 1. Check all parts for scoring, burrs, chips, corrosion, distortion, and excessive wear. Give particular attention to internal areas and threads.
  - 2. Check O-rings and seals for twists and nicks. Check seals to see if they are collapsed.
  - 3. Check snap rings for excessive wear or abuse.
- E. Repair or replace as follows:
  - 1. Deburr all surfaces. Polish ball and valve seats. Polish all seal seating surfaces.
  - 2. Replace all internal metal parts that exceed clearance tolerances or where burrs, scratches, or scoring cannot be removed.
  - 3. Replace twisted or nicked O-rings and abused snap rings.
- F. During assembly of component parts, apply a thin coat of oil (same as used in Power Unit reservoir, see paragraph 2-2 to internal machined surfaces of parts.

# 4

# OVERHAUL

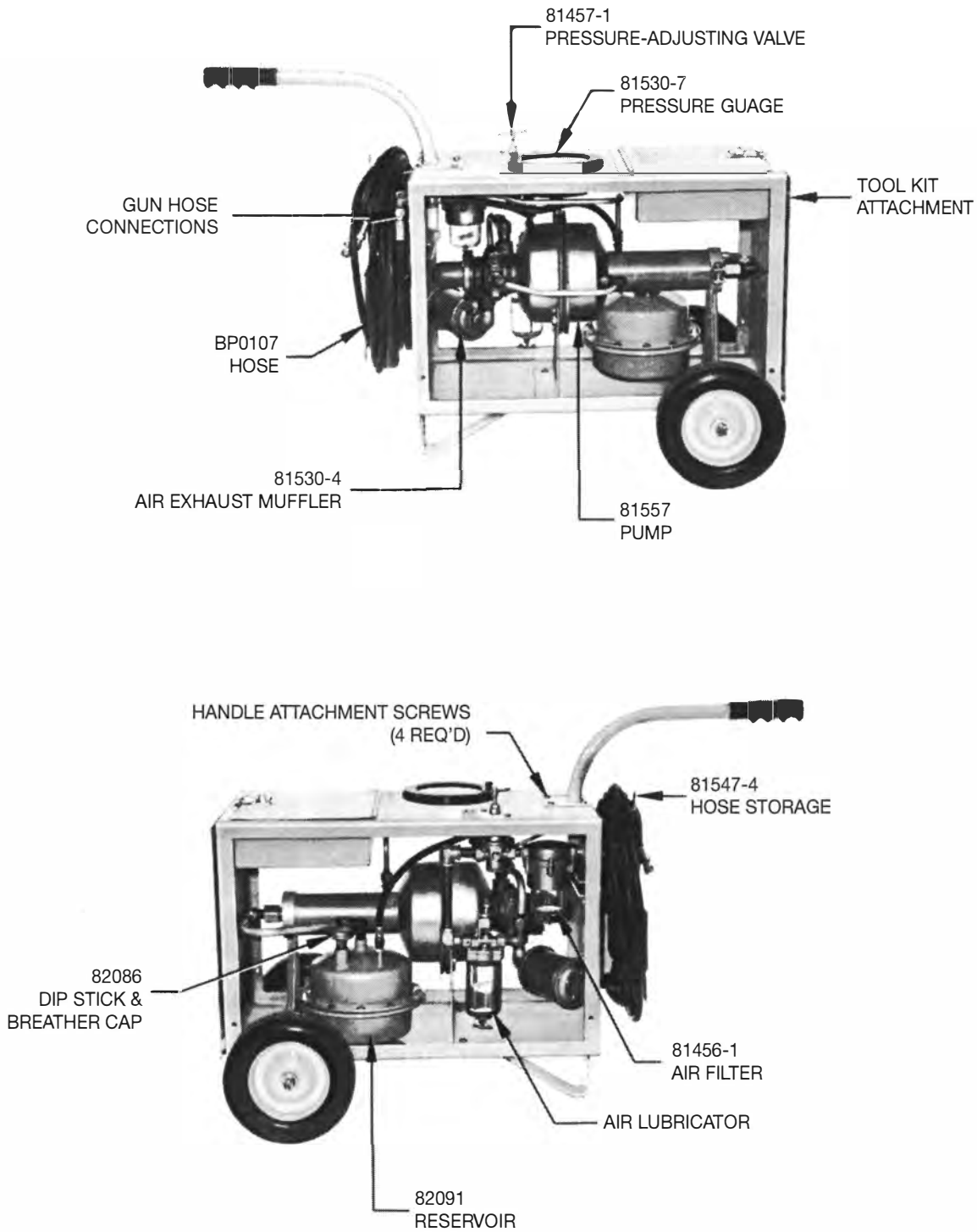

FIGURE 5. BP7000 POWER UNIT WITH SIDE PANELS REMOVED

**SECTION 5: ORIGINAL MANUFACTURER'S DATA**

**HANDBOOK**

Operation and Service  
with  
Illustrated Parts Breakdown

**AIR OPERATED PUMP**  
Model 81557

## TABLE OF CONTENTS

Section		Page
I	INTRODUCTION AND DESCRIPTION	
1.1	Introduction	17
1.2	Purpose of the Equipment	17
1.3	General Description	17
II	INSTALLATION	
2.1	General	18
2.2	Installation	18
III	OPERATING INSTRUCTIONS	
3.1	General	20
3.2	Start	20
3.3	To Set Output Pressure	20
3.4	Stop	20
IV	INSPECTION AND MAINTENANCE	
4.1	Service Tools Required	21
4.2	Inspection and Maintenance	21
4.3	Air Filter Maintenance	21
4.4	Lubricator Maintenance	22
4.5	Pump Maintenance	23
4.6	Pump Trouble Shooting	23
4.7	Trouble Shooting Chart	24
V	DISASSEMBLY, INSPECTION, REPAIR AND REASSEMBLY	
5.1	Disassembly	25
5.2	Inspection	25
5.3	Repair and Replacement	26
5.4	Reassembly	26
5.5	Test Conditions	28
VI	ILLUSTRATED PARTS BREAKDOWN	
6.1	Introduction	29



**LIST OF ILLUSTRATIONS**

Figure No.		Page
2-1.	Table of Accessories	18
2-2.	Installation	18
4-1.	Table of Inspection and Maintenance	21
4-2.	Trouble Analysis Chart	24
6-1.	Pump Assembly	30
6-2.	Lubro-Control Unit	33-36

## **SECTION I**

### **INTRODUCTION AND DESCRIPTION**

#### **1.1 INTRODUCTION**

This publication is issued as the basic Handbook of Operations and Service Instructions with Illustrated parts Breakdown and Recommended Spares for the Model 81557 (BP7000) Air-Operated Hydraulic Pump.

#### **1.2 PURPOSE OF THE EQUIPMENT**

The Model 81557 Pump is designed for high pressure fluid pumping applications.

#### **1.3 GENERAL DESCRIPTION**

The pump is a piston type, double acting, air-operated incorporating an automatically operated, snap action air selector valve. The pump is ready-to-use, requiring only connection to an operating air supply, fluid supply and the system to be serviced to place it in operation.

a. The pump develops the following flows at 100 psig operating air pressure:

2 gpm at 500 psig

1/4 gpm at 3000 psig

b. Pumping action is produced by three moving parts: a Drive Piston, Driven Piston and an Air Selector Valve.

1. The Drive Piston and the Driven Piston are threaded together and operate as a unit.

2. Air pressure to operate the Drive Piston is directed alternately to the top and bottom of the piston by the Air Selector Valve. This valve, in turn, is shifted by the Drive Piston at end of its stroke.

3. Directional control of the fluid flow between the suction and delivery strokes is maintained by inlet and outlet check valves.

4. Pump delivery depends upon the differential between the total force exerted by the Drive piston and the total force developed by the Driven piston. As these two forces approach equality, pump delivery decreases, ceasing entirely when the two forces are in balance. The pump operates intermittently, thereafter to maintain the forces in balance.

## SECTION II

### INSTALLATION

#### 2.1 GENERAL

The Model 81557 Pump is complete and requires only connection to an operating air supply, fluid supply, and mounting to prepare for use.

A Lubro-Control unit should be installed in the operating air line. For maximum operations efficiency certain accessories are recommended. Figure 2-1 lists these accessories by name, part number and manufacturers.

PART NAME	PART NUMBER	MANUFACTURERS
Lubro-Control	Type BO1	Norgren
Muffler	Model 5	Allied Witan
Gauge (0 to applicable range) Output pressure	Figure 50 3 1/2 in. dial	Marshalltown Mfg.
Angle Valve, Operating Air	907BS 1/2 in.	Luckenheimer
Needle Valve, Outlet Shutoff	10F 1/4 inch or 3/8 inch	Dragon Eng. Corp.

**FIGURE 2-1. TABLE OF ACCESSORIES**

The Lubro-Control unit provides the filtration, regulation, and lubrication of the operating air required by the pump. The pressure gauge indicates the adjusted operating air pressure.

Exhaust air noise may be reduced by installing a muffler in the pump's Air Exhaust outlet.

A valve installed in the operating air line, ahead of the Lubro-Control unit provides on-off control of pump operation.

#### 2.2 INSTALLATION

- a. Install the pump in the required location. Bolt pump in place, see Figure 2-2 for installation dimensions.
- b. Install accessory components in the operating air supply and high pressure system in accordance with the installation in which the unit is being used, see Figure 2-2 for installation methods.
- c. Adjust and fill operating air lubricator, refer to paragraph 4.4.
- d. Connect external system to pressure outlet.
- e. Connect operating air supply to the 3/8 inch NPT port on air line filter or the operating air shutoff valve.

**KEY**

- 1. Operating Air Shutoff
- 2. Lubro-Control Unit
- 3. Operating Air Pressure Gage
- 4. Muffler
- 5. Output Pressure Gage
- 6. Outlet Shutoff Valve

Air Inlet Port 1/2 - 14 NPT

Air Exhaust Port 1/2-14 NPT

Fluid Inlet Port 3/8-18 NPT

Fluid Outlet Port 1/4-18 NPT

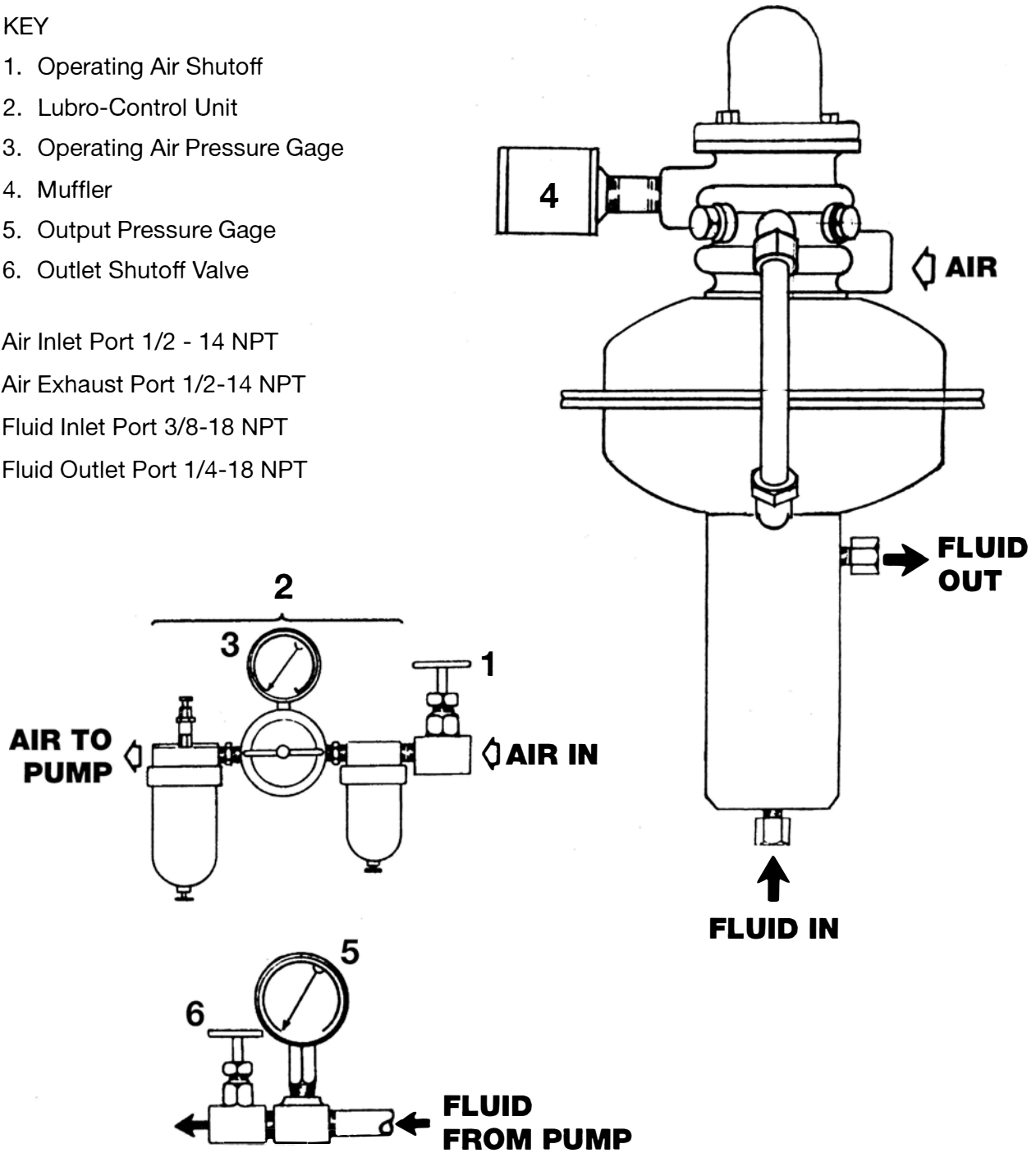

**FIGURE 2-2. INSTALLATION**

## SECTION III

### OPERATING INSTRUCTIONS

#### 3.1 GENERAL

These operating instructions are general and must be supplemented as required to agree with the type of installation and accessories used.

#### 3.2 START

- a. Turn operating air supply on.
- b. Adjust operating air regulator for required output pressure.

CAUTION: Do not exceed 100 psig maximum operating air pressure.

1. The Model 81557 has an approximate ratio of 36 psig output pressure for each psig operating air pressure. The pump has an operating pressure of 3000 psig. It has a maximum output pressure of approximately 3250 psig and will continue to operate intermittently to maintain this pressure.

- c. Slowly open outlet shutoff valve.

#### 3.3 TO SET OUTPUT PRESSURE

- a. Adjust operating air pressure regulator for required output pressure.
- b. Allow pump to build up pressure and stall out.

Note output pressure.

Adjust operating air pressure until required pressure is obtained.

#### 3.4 STOP

- a. Close operating air shutoff valve.
- b. Close outlet shutoff valve.

**SECTION IV**

**INSPECTION AND MAINTENANCE**

**4.1 SERVICE TOOLS REQUIRED.**

No special tools are required for servicing the unit.

**4.2 INSPECTION AND MAINTENANCE**

- a. The maintenance schedule, Figure 4-1, is intended as a guide, recommended inspection periods may require adjusting to comply with local conditions or as warranted by experience.
- b. A trouble shooting chart is included, Figure 4-2 to check the pump in a systematic manner to isolate and eliminate the source of trouble.

ITEM	PERIOD	PROCEDURE
Operating Air Filter	10 hours	Drain condensate.
	50 hours	Check filter element for clogging. Clean as required. Refer to 4.3 for procedure.
Operating Air Lubricator	10 hours	Check oil level. Use SAE #10 oil. Check lubricator adjustment. Refer to 4.4 for procedure.
Pump	10 hours	Check pump and fittings for evidence of external leakage. Repair as required.
Pressure Gauge	10 hours	Zero out.
	50 hours	Calibrate against a master gauge.

**FIGURE 4-1. INSPECTION AND MAINTENANCE**

**4.3 AIR FILTER MAINTENANCE (See Figure 6-2)**

- a. Maintenance of the air filter is minimized due to the absence of moving parts. To inspect or repair the filter, proceed as follows:

**CAUTION:** Do not attempt to unthread the retaining ring until line pressure to the filter has been shut off and the pressure bled from the filter.

1. Unthread ring and remove bowl.
2. Unthread filter retaining nut and remove filter element.
3. Wash element in a cleaning solvent and blow out with compressed air.
4. Reassemble, make sure "O" ring is properly placed.

**NOTE:** Inspect "O" ring for nicks and cuts. If damaged, replace.

#### 4.4 LUBRICATOR MAINTENANCE (See Figure 6-2)

- a. Normal operating temperature of the lubricator is 60°F. A high quality lubricating oil of approximately 150 to 200 seconds S.U.V. (SEAE #10) at 100°F. in accordance with Military Specification MIL-L-2104, is recommended.
- b. Adjust lubricator as follows: Close lubricator needle valve; turn on air; allow pump to operate; slowly open and adjust needle for 1 to 4 drops of oil minute.
- c. If servicing of the lubricator is necessary, proceed as follows:
  1. Turn off air supply. Remove top plug and drip gland and inspect for impurities in the oil passage and on top of and in the drip gland. Thoroughly clean parts with petroleum solvent and blow out with compressed air.
  2. If oil or air leaks around the sight feed glass:
    - a. Remove top plug and tighten drip gland.
    - b. If trouble persists, unscrew drip gland and inspect gasket on top and bottom of sight feed glass. Replace gasket if necessary. Reassembly, tightening drip gland firmly but carefully.
  3. If there is a leak around the needle valve:
    - a. Tighten needle valve packing nut.
    - b. If trouble persists, unscrew valve packing nut and inspect packing. Replace if necessary.
  4. If a leak occurs between bowl and body:
    - a. Make certain internally threaded clamp ring is firmly tightened.
    - b. If trouble persists, remove bowl and inspect "O" ring. Replace if necessary. When re-assembling, make certain "O" ring is properly place in groove.

CAUTION: If bowl requires cleaning, wash in a petroleum solvent. DO NOT USE ACETONE, ETHYL ACETATE, ETHYLENE DICHLORIDE TOULUENE, etc., as these solvents will damage and deteriorate the bowl.

#### 4.5 PUMP MAINTENANCE

A four detent Air Valve and Housing Assembly is used on the 31557 pump. Parts to maintain the detent assembly are procurable and listed in the Illustrated Parts Breakdown.

- a. **EXCLUSION OF FOREIGN MATTER.** All openings in the hydraulic system must be properly covered to exclude foreign matter.

**NOTE:** When the pump is disassembled for repairs, all matched parts should be carefully handled to avoid damage to lapped or honed surfaces.

- b. **REPLACING GASKETS AND SEALS.** It is recommended that all gaskets and seals that have been removed, be replaced with new ones.
- c. **REPLACEMENT PARTS.** Use only parts shown in the Illustrated Parts Breakdown.
- d. **LUBRICATION.** Lubrication of the Driven Piston is provided by the hydraulic fluid. Lubrication of the other moving parts in the pump is provided by lubricant from the air line lubricator.

#### 4.6 PUMP TROUBLESHOOTING

- a. The following **TROUBLE ANALYSIS CHART** has been made as comprehensive as possible to expedite pump repair by maintenance personnel. The chart lists the troubles that may possibly be encountered, indicates the probable causes, and states the remedy for each trouble. To eliminate unnecessary disassembly of the pump, the probable causes of pump troubles are listed in the following order.
  1. Causes that can be corrected without disassembly of the pump for correction.
  2. Causes requiring partial disassembly of the pump.
  3. Causes requiring complete disassembly of the pump for correction. It is recommended that the service mechanic trouble shoot the unit for trouble causes in the order listed.
- b. For complete instructions on Disassembly, Reassembly, and Repair Procedures, refer to Section V. For Replacement Part Numbers, refer to Illustrated Parts Breakdown.



# 5

## ORIGINAL MFG'S DATA



TROUBLE	PROBABLE CAUSE	REMEDY
Pump not delivering	1. Operating Air Supply line disconnected, or Air Shutoff Valve closed.	1. Reconnect Air Supply open Air Shutoff Valve.
	2. Air Pressure Regulator not adjusted.	2. Adjust Air Pressure Regulator
	3. Fluid Supply Low.	3. Add Fluid as required.
	4. Foreign material lodged in Inlet Check Valves.	4. Remove and clean Check Valves.
	5. Air Selector Valve sticking or Spring (43) broken or Pins (44) worn.	5. Replace detent pins (44). Replace Spring if broken.
	6. Connecting Rod (19) improperly adjusted. (This trouble may be encountered after pump had been disassembled for service).	6. Re-adjust connecting rod. (Refer to Para. 5.4, steps q thru r.)
	7. Spring (10) broken.	7. Replace Spring.
	8. Spring (16) broken.	8. Replace Spring.
	9. Drive piston or driven piston binding due to misalignment.	9. Realign Housing on Body. Loosen NUT (24) and refer to para. 5. steps i thru k.
Pressure Drops or Failure to Build Up Pressure	1. Foreign material lodged in outlet check valves. Burrs or nicks on seat.	1. Remove and clean check valve. Remove and inspect seat for nicks or burrs or excessive wear.
	2. Defective "O" ring and Backup Rings in Body	2. Replace defective "O" ring and Backup rings.
	3. Defective "O" ring on Drive Piston allowing Operating Air Pressure to escape to Exhaust Outlet.	3. Replace "O" ring (22). Inspect cylinder for scores or scratches.
	4. Both Check Valves leaking.	4. Remove and inspect both Check Valves for foreign material lodged on valve seats, burrs or nicks. Service as required and replace.
	5. Defective "O" ring on Driven Piston	5. Replace "O" ring (33) and Backup Ring (34).
Pump fails to build up to maximum pressure.	Connecting rod (19) incorrectly adjusted.	Readjust connecting rod, (Refer to para. 5.4, step q thru r.
Hydraulic fluid in exhaust air	Defective "O" ring and backup rings in body, or scores on driven piston	Replace "O" ring and backup rings. Inspect piston for scores marks and polish if required.
Air leak at the air valve housing assembly cover	Cover loose or defective gasket.	Tighten cover bolts or replace "O" ring as required.
Air leak between flanges of upper and bottom housing.	Attaching bolts loosen or defective "O" ring.	Tighten bolts or replace "O" ring as required.
Air leak between bottom housing and piston body.	Body not assembled tightly to bottom housing, or defective gasket.	Tighten as required, or replace gasket if defective.
Air in system.	1. Small air leak at pump inlet check valves.	1. Tighten or replace fittings.
	2. Fluid supply level below pump suction.	2. Refill supply.

FIGURE 4-2. TROUBLE ANALYSIS

**SECTION V****DISASSEMBLY, INSPECTION, REPAIR AND REASSEMBLY****5.1 DISASSEMBLY**

This section provides disassembly instructions for the Model 81557 Pump. It should be noted, that for the replacement of specific parts, the pump need only be disassembled as far as is necessary to permit access to the part involved. The numbers in parenthesis following the part names, correspond to the Index Numbers on the applicable Illustrated Parts Breakdown Illustration.

To facilitate disassembly, the body may be held in a vise. Aluminum or brass jaws should be installed on the vise to prevent mutilation of the body.

**CAUTION:** Do not place body in vise with body threads contacting jaws. To prevent distortion of matched parts, **DO NOT TIGHTEN VISE JAWS EXCESSIVELY.**

- a. Remove pump from installation for complete disassembly.
- b. Disassemble the pump in the order of the key index numbers assigned to the pump illustration. (See Fig. 6-1).
- c. Immerse and wash all metallic parts in solvent, Federal Specification P-D-680. Dry thoroughly with moisture-free compressed air at 20psig maximum, or use a clean lint-free cloth.

**WARNING:** Use cleaning solvent in a well ventilated area. Avoid breathing fumes.  
Keep away from open flames.

Remove hardened sediment with a soft bristled brush. Do not scrape parts with a metal tool.

**5.2 INSPECTION (See Figure 6-1)**

- a. Under a strong light and preferably under magnification, visually inspect all applicable parts for cracks, pitting, scoring and corrosion.
- b. Inspect all threads for chipped, crossed, or stripped threads.
- c. Check free length of spring (43), to be 3/4 in. lg.
- d. Check free length of spring (10), to be 7/8 in. lg.
- e. Check free length of spring (16), to be 5/8 in. lg.
- f. Roll spring (10, 43, 16) over a flat surface to check for wobble and permanent set.
- g. Inspect air valve (13) lands for excessive wear caused by detent pins (44).

**CAUTION:** The air valve and housing assembly is a matched assembly.  
Be careful not to scratch ID of body.

### 5.3 REPAIR AND REPLACEMENT

- a. Remove minute imperfections, minor scratches or scoring from ferrous parts by carefully polishing with crocus cloth, Federal Specification P-C-458, from non-ferrous parts with P-C-451.
- b. Piston and Body. Minor nicks or scratches on the piston may be removed by polishing with wet-04-dry paper, grip No. 400-A. Minor scratches or scores in the body bore may be polished out on a hone. Use a very fine grit polishing stone for the honing operation.
- c. Air valve-housing Assembly. Repair minor defects in this assembly in the same manner as outlined in step b.

**CAUTION:** The operational efficiency of the pump depends upon close tolerances between the parts of the Air-Valve-Housing Assembly and the Piston and Body; keep polishing and honing to an absolute minimum. If parts are badly nicked or scored, replace the entire assembly.

### 5.4 REASSEMBLY

Lubricate "O" ring packings, backup retainers and threads with hydraulic fluid, Federal Specification MIL-H-5606 or petrolatum, Federal Specification VV-P-236. Avoid excessive application of lubricant.

NOTE: Item numbers used to identify parts agree with the key index numbers on figure 6.1.

- a. Reassembly in the reverse order of disassembly.
- b. Thread shifting nut (17) on connecting rod (19) with top of the nut facing toward the center of the connecting rod. Thread nut (17) up the connecting rod, covering all the threads.
- c. Place "O" ring (26) on body (40). Install housing (25) on body (40). Install nut (24) and tighten only to retain body and housing in position.
- d. Install elbows (2 and 3).
- e. Place air valve - housing on housing (25). Line up air inlet with the fluid outlet port of the piston body (40).
- f. Install tube (1) on elbow (2). Rotate housing (25) until elbow (3) lines up with tube (1). Remove tube (1) and air valve housing.
- g. Insert cylinder (15) in housing (25).
- h. Install the drive piston (21) and rod assembly (19) in housing (25) guide the driven piston (32) carefully into the piston body (40).

NOTE: Do not install "O" rings and backup retainers in the piston body until the following adjustment has been completed.

- i. Slowly rotate drive piston (21) through 360 degrees, checking for binds between drive piston and cylinder or driven piston (32) and body (40). Remove binds by shifting housing (25) on body (40) as required.
- j. When piston (21) can be rotated 360 degrees without binding at any point, remove drive piston and driven piston, tighten nut (24) securely.
- k. Install set screws (23) and tighten.
- l. Install backup ring (38) and "O" ring (39) in piston body (40).
- m. Insert spring, ball guide and ball (37) into piston (32). Install "O" ring (36), thread check valve body (35) into piston (32) and tighten.
  - 1. Install backup ring (33) and "O" ring (34) on piston (32). Guide driven piston (32) into piston body (40). Exercise care not to damage piston "O" ring.

Install "O" ring (22) on drive piston (21). Install drive piston in housing and tighten on driven piston (32) by holding driven piston at the check valve body using a 1 inch socket.

- n. Install check nut (20) on driven piston (32) and tighten. Install lock washer (18) and thread connecting rod (19) into driven piston (32) until it bottoms. Tighten shifting nut (17), place spring (16) over shifting nut.
- o. Position air valve (45) in air valve housing (13) with the top of the air valve just below the top groove in the valve housing as illustrated in figure 6.1. Install detent pins (44), spring (43) and bolts (41) with "O" rings (42) in detent holes. Tighten each bolt (41) until it bottoms.
- p. Install "O" ring (14) in housing (25). Place air valve housing on housing (25), align elbows (2 & 3) and evenly tighten bolts (11 & 12).
- q. With the air valve and drive piston (21) in the up position, install spring (10) and nut (9) on connecting rod. Place lock washer (8) and lock nut (7) on connecting rod and tighten until the bottom of nut (9) is flush with the top of the air valve.

NOTE: The air valve and piston may be operated up and down by applying air pressure (10 psig maximum) alternately to elbows (2 & 3).

- r. Check air valve shifting; cycle pump several times. If air valve does not shift at the end of each stroke, turn nut (9) down 1/2 turn; recheck shifting. Install tube (1).
- s. Install ball, ball guide and spring in check valve body (27). Install gasket (29) and thread check valve into plug (30). Install "O" ring (31) on plug (30) and thread into piston body (40) until it bottoms.

**5.5 TEST CONDITIONS**

- a. Install pump in a typical circuit such as illustrated in figure 2-2. operate in accordance with operating instructions in Section III.
- b. TEST. Conduct a series of tests, operating the pump with different operating air pressures. Close the shutoff valve in the pressure line each time to permit the pump to build up to its maximum output pressure.

## **SECTION VI**

### **ILLUSTRATED PARTS BREAKDOWN**

#### **6.1 INTRODUCTION**

- a. **GENERAL.** This Illustrated Parts Breakdown List, describes and illustrated the assemblies, subassemblies and detail parts for the Model 81557 Air-Operated Pump.
- b. **REPLACEMENT PARTS.** Order replacement parts by part number and nomenclature only. Always reference pump series and model number. Index numbers are referenced to the illustrations and are used mainly to assist in locating parts in the Group Assembly Parts List.
- c. **ILLUSTRATIONS.** Each parts list is accompanied by an illustration which identifies all component parts and is arranged to show the relationship of the parts to each other. Index numbers on the illustration refer to the accompanying Group Assembly Parts List and are assigned in the order of disassembly.
- d. **PART NUMBERING SYSTEM.** AN, AND and MS numbers are Government Standard Parts. The symbol COML has been inserted in the "PART NUMBER" column to indicate parts to which no Government standard or manufacturer's part number has been assigned. Such parts generally are procurable from many sources and are completely identified in the "DESCRIPTION" column for purpose of procurement.
  1. The quantities specified in the "RECOMMENDED SPARES" column are per unit and are based on two years maintenance requirements.
- e. **UNITS PER ASSEMBLY.** Quantities specified in the "QUANTITY" column are the total number of each part required per assembly.

## 6.1 ILLUSTRATED PARTS BREAKDOWN

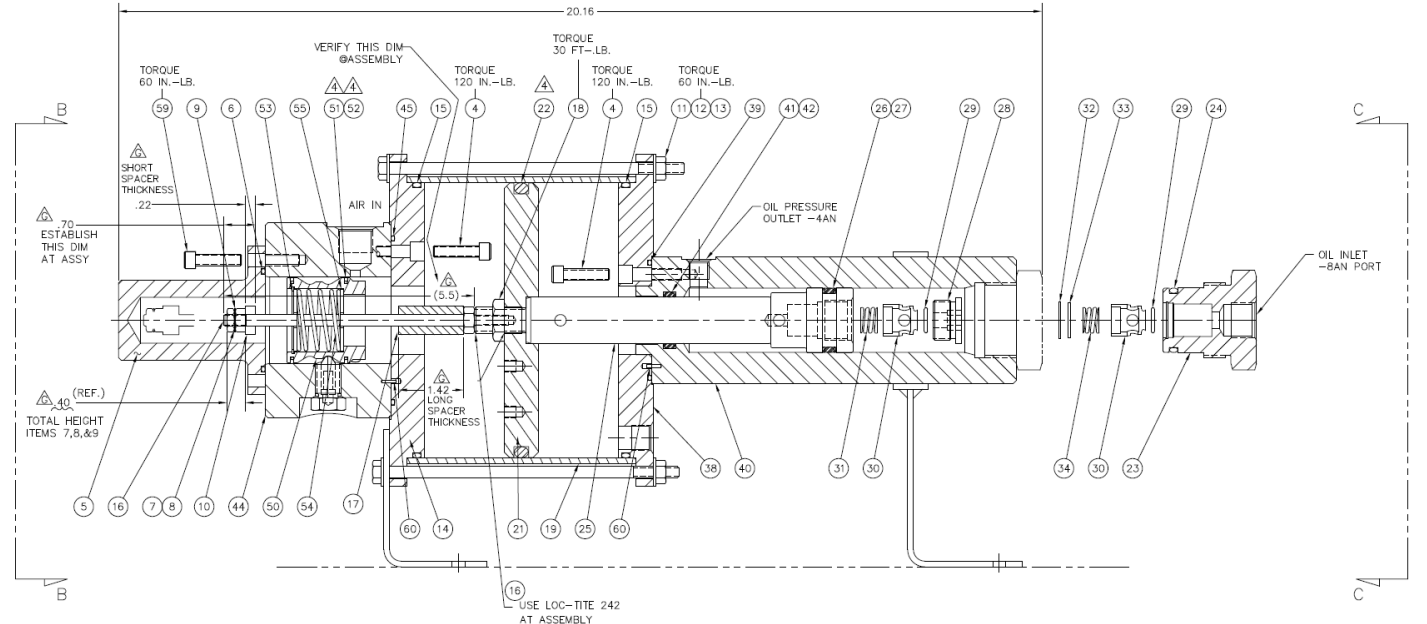

### NOTES

1. OPERATE WITH LUBRICATED AIR MAX. INLET AIR PRESSURE 100 PSIG
2. AIR OIL PISTON RATIO = 36:1
3. FLOW: 2 GPM @ 500 PSI  
25 GPM @3000PSI
4. APPLY BARIUM GREASE TO SLIDING SURFACES OF SEALS (ITEMS 22, 51, 52) AND THEIR PERSPECTIVE BORES @ ASSEMBLY

### SECTION A-A

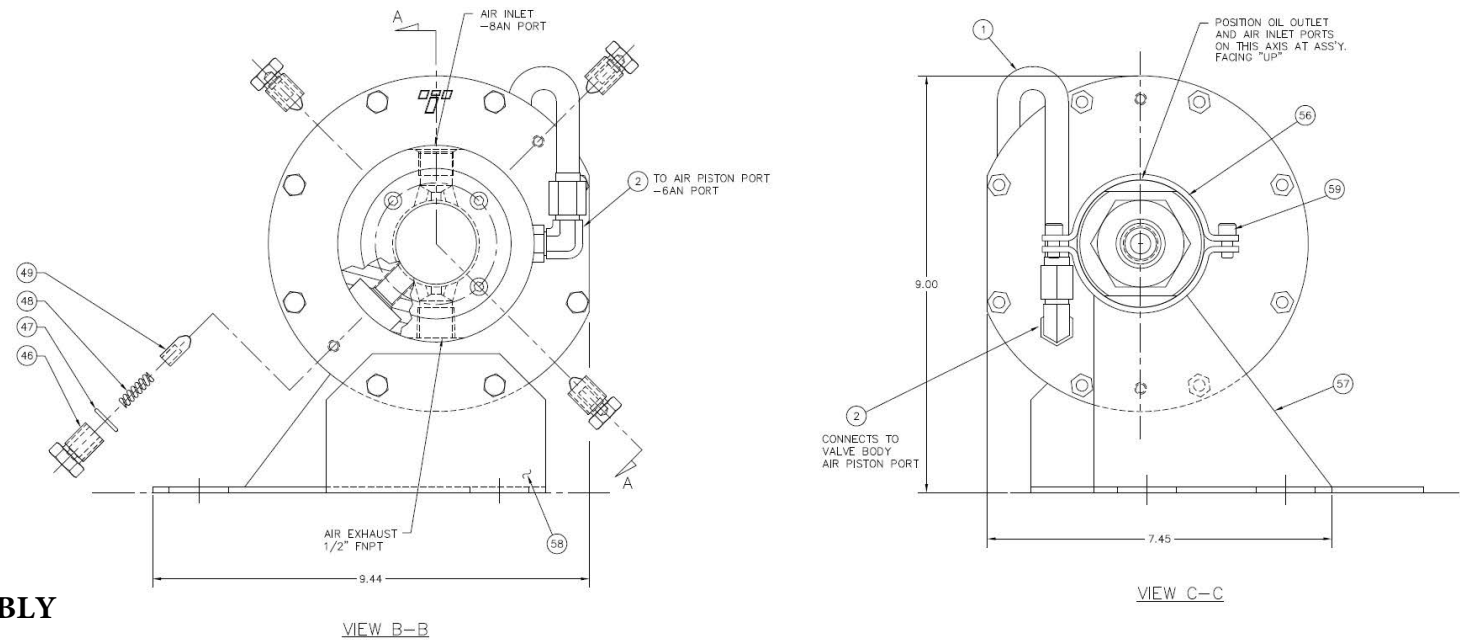



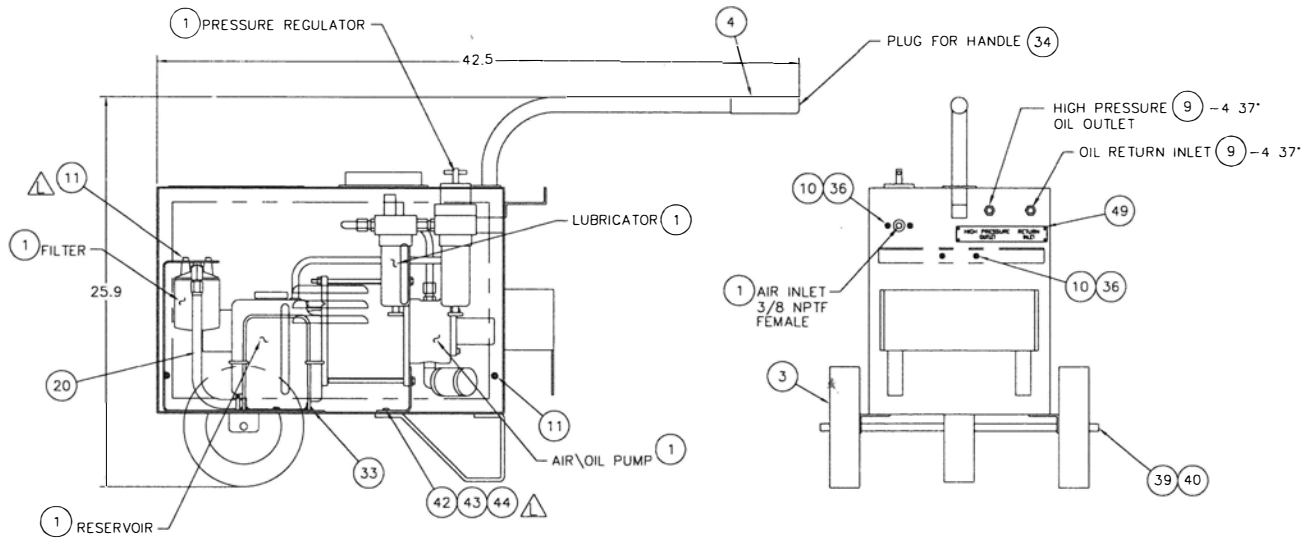
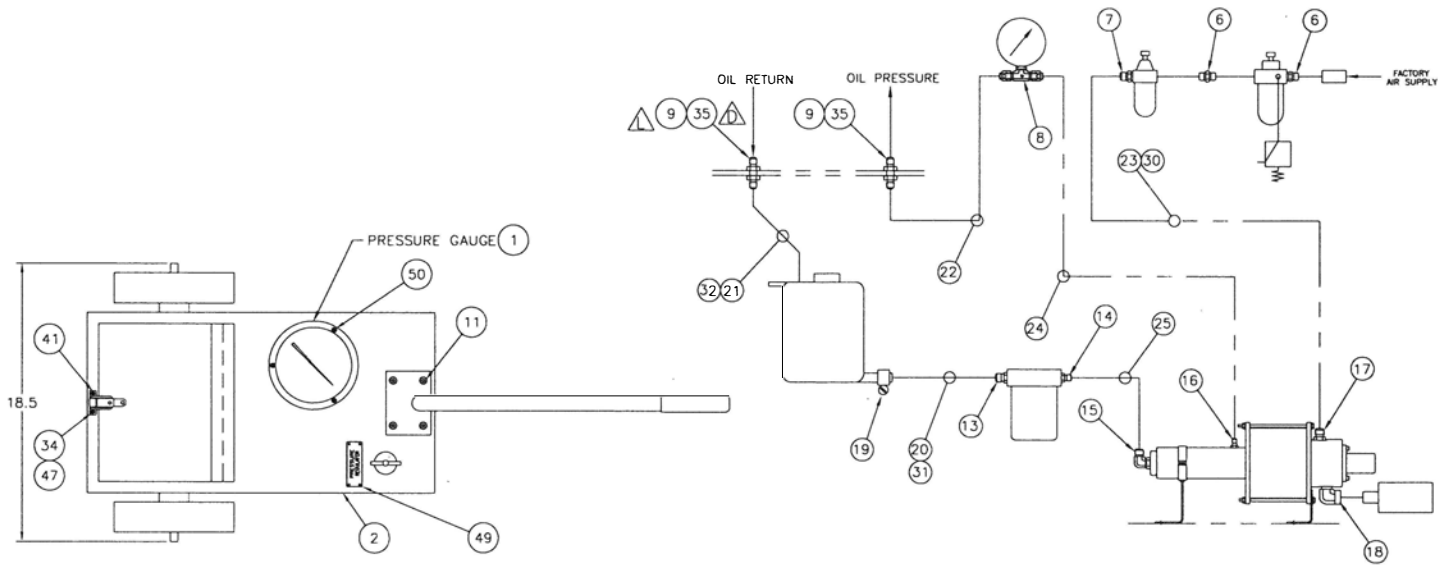

FIGURE 6-1 PUMP ASSEMBLY

## 6.1 ILLUSTRATED PARTS BREAKDOWN (continued) - PARTS LIST

ITEM	PART NUMBER	SUPPLIER	DESCRIPTION	QUANTITY
1	3437731	Team	Hose Assembly	
2	6C50X-S	Parker	Straight Thread Elbow	
3	6C50X-S	Parker	Straight Thread Elbow	
4	1/4"- 20 x 1.0" Lg		SHCS	4
5	3437715	Team	Cover, Air Valve	1
6	2-137N674-70	Parker	O-Ring	
7	1/4"- 20	McMaster	Shifting Nut (deformed)	
8	1/4"	McMaster	Star Washer	
9	1/4"- 20	McMaster	Hex Nut	
10	3437720	Team	Spacer, Short	
11	1/4"- 20		Hex Nut	8
12	1/4"	SAE	Washer, Flat	16
13	1/4"- 20 x 6.5" Lg		H.H.C.S., Grade 2	8
14	3437712	Team	Upper End Plate, Air Cyl.	1
15	2-256N674-70	Parker	O-Ring	2
16	3437709	Team	Connecting Rod	
17		Team	Spacer, Long	
18	9/16"- 18		Hex Jam Nut	
19	3437714	Team	Tube, Air Cylinder	
20	2-256N674-70	Parker	O-Ring	2
21	3437711	Team	Piston, Air Cylinder	
 22	2-433N674-70	Parker	O-Ring	
23	3437716	Team	Fitting, Oil Inlet	
24	2-216N674-70	Parker	O-Ring	
25	3437702	Team	Piston, Oil Cylinder	
26	2-216N552-90	Parker	O-Ring	1
27	MS28782-21		Backup Ring (Teflon)	2
28	3437717	Team	Fitting, Check Valve	1
29	2-110N552-90	Parker	O-Ring	2
30	3437703	Team	Check Valve	2
31	3437722	Team	Spring, Check Valve	2
32	I.R.R. 3000-X75		Snap Ring, Internal	1
33	91083A030	McMaster	Washer, 11/32" ID x 11/16" OD x 1/16" THK.	1
34	3437722	Team	Spring, Check Valve	2
35	3437703	Team	Check Valve	2
36	2-110-N552-90	Parker	O-Ring	1
37	1/4"- 20 x 1.0" Lg.		SHCS	4
38	3437713	Team	Lower End Plate, Air Cyl.	1
39	2-143N674-70	Parker	O-Ring	
40	3437704	Team	Body, Oil Piston	
41	2-214N552-90	Parker	O-Ring	1
42	MS28782-19		Backup Ring (Teflon)	2
43	1/4"- 20 x 1.0" Lg.		SHCS	4
44	3437708	Team	Body, Air Valve	
45	2-153N674-70	Parker	O-Ring	1
46		Team	Housing, Detent	4
47	3-906	Parker	Gasket	4
48	3437721	Team	Spring, Detent	4
49	3437707	Team	Plunger, Detent	4
50	3437701	Team	Spool, Air Valve	1
 51	3437718	Team	Seal, Air Valve Spool	2
 52	2-029N674-70	Parker	O-Ring	2
53	I.R.R. 3000-137		Snap Ring, Internal	
54	3437723	Team	Spring, Spool	
55	3437710	Team	Keeper, Spring	
56	3437738	Team	Pump Clamp	
57	3437739	Team	Pump Support Clamp	
58	3437740	Team	Pump Support	1
59	1/4"- 20 x .75"		SHCS	2
60	1/16" O.D. x 5/16"		Roll Pin	2





**SPECIFICATIONS**

1. REQ'D AIR SUPPLY: 90 PSIG
2. REQ'D. OIL: MIL-H-5606
3. MAX PRESSURE: 2500 PSI
4. FLOW: .25 GPM @ 2500 PSI  
2 GPM @ 500 PSI

“DESIGNER SERIES” FILTER REGULATOR

1/4" & 3/8" • FOR COMPRESSED AIR SERVICE

OPERATION

Flow through the directional louvers (A) forces air into a swirling pattern. Liquids and heavy solids in the air stream are directed away from the filter element and held against the inside of the bowl by centrifugal force. They move down the bowl wall into the quiet zone (B) below the baffle. The baffle (C) maintains the quiet zone in the lower part of the bowl to prevent air turbulence from picking up the liquid and returning it to the air stream. Air then flows inward and passes through the filter element (D) which further cleans the air and removes the fine solids. Liquids accumulated in the filter quiet zone are drained off through the manual drain or an automatic drain (J).

Clean air flows from the filter element directly to the regulator valve (E). As the adjusting screw is turned in, it applies a load to the adjusting spring which is transmitted to the valve through the diaphragm and the valve pin, thus opening the valve. As the regulated pressure increases, the pressure against the diaphragm increases, causing the diaphragm to compress the adjusting spring until the load exerted by the regulated pressure equals the spring load. If there is no flow demand, this state of equilibrium will occur with the valve closed. If there is a flow demand, this state of equilibrium will occur with the valve open just the amount necessary to compensate for the demand, thus maintaining the desired regulated pressure.

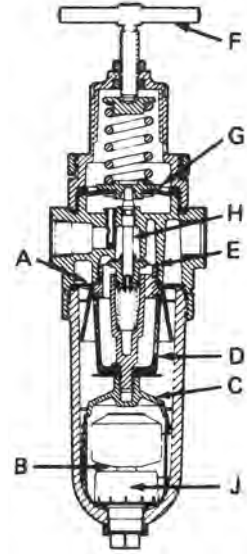

INSTALLATION

Install with air flow through unit in the direction indicated by the arrow located on the body.

Pipe should be same size as porting in the regulator. In cyclic operation the regulator is normally located upstream of control valves.

Before turning on air pressure rotate adjusting screw or knob in counter-clockwise direction to relieve any loading on main regulating spring. Check gauge ports. Pipe plugs or gauge should be installed in gauge ports if not used as auxiliary flow ports.

Turn on air pressure and adjust required secondary pressure by turning adjusting screw or knob in clockwise direction. For correct pressure setting, always adjust to the required pressure from a lower pressure. When re-adjusting from a higher secondary pressure, adjust below required pressure setting first and then adjust up to required pressure.

When filter/regulator is located in an inaccessible position, or when excessive amounts of water are encountered, auto-matic drain models should be used. Manual drain models must be drained periodically. Water level in bowl should not be allowed to raise above the baffle or water will carry over downstream.

GRAPHIC SYMBOL

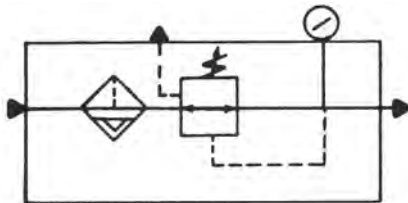

CAUTION

THIS FILTER/REGULATOR SHOULD NOT BE USED WHERE PRESSURE OR TEMPERATURE MAY EXCEED SPECIFIED MAXIMUM RECOMMENDED OPERATING CONDITIONS. USE WITH MEDIA OTHER THAN COMPRESSED AIR IS NOT RECOMMENDED. USE ONLY CLEAN, WARM WATER OR KEROSENE TO CLEAN POLYCARBONATE BOWL.

SPECIFICATIONS

PIPE SIZES: 1/4", 3/8"

FILTER ELEMENTS

SINTERED BRONZE:

50 Micron (STANDARD)

5 Micron (OPTIONAL)

25 Micron (OPTIONAL)

AUTOMATIC OR MANUAL DRAIN

REGULATOR SECTION: RELIEVING OR NON-RELIEVING

GAUGE PORTS: TWO 1/4" FULL FLOW

PRIMARY PRESSURE:

200 PSI AT 120°F. — POLYCARBONATE

250 PSI AT 175°F. — METAL BOWL

\*SECONDARY (REGULATED) PRESSURE RANGES:

1-50 PSI

2-125 PSI

5-175 PSI

\*Can be adjusted to 0.

DIMENSIONS

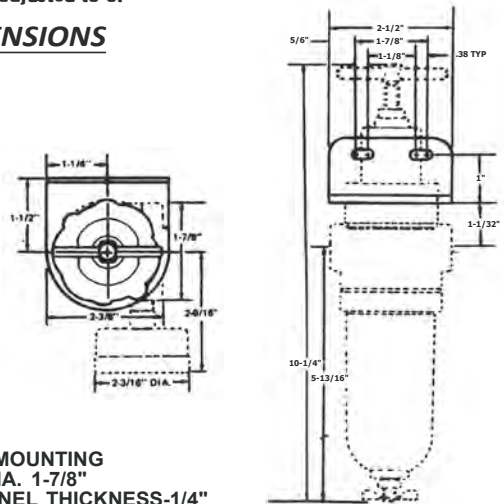

PANEL MOUNTING HOLE DIA. 1-7/8" MAX-PANEL THICKNESS-1/4"

19. Filter Element (kit includes gaskets):
- 5 Micron . . . . . 3161-04
  - 25 Micron . . . . . 3161-02
  - 50 Micron . . . . . 3161-03

26. Transparent bowl assembly (manual drain) . . . . . 3155-53  
 Metal bowl assembly (manual drain) . . . . . 3170-50  
 (Bowl assemblies include insert, gasket, bowl  
 retainer, drain cock)  
 Transparent bowl only . . . . . 3150-03  
 Metal bowl only . . . . . 3170-02
30. Automatic drain (includes gasket) . . . . . 3000-03  
 29. Float assembly (for automatic drain models) . . . . . 3003-50

- ACCESSORIES:  
 Bowl guard (includes retainer spring) . . . . . 5176-02  
 Mounting bracket . . . . . 5203-01

MAINTENANCE

For maintenance and servicing, the filter-regulator can easily be disassembled. To do this, shut off air supply and bleed down pressure, then IP"BIP bowl (26) firmly and unscrew. The gasket (23) will normally remain in the body.

Unscrew the baffle (22) and remove the filter shield (21) and the filter element (19). Then unscrew the filter guide (17) which will release the louver (15), deflector (16) and gasket (14).

The bonnet (41) can be removed by turning in a counterclockwise direction.

On filter-regulators containing an automatic drain (29-30-31) the float assembly (30) is not attached and will drop out when bowl is turned upside down. The float (30) and automatic drain assemblies are not considered to be repairable items. The automatic drain and strainer 1291 are easily removed by loosening the retaining ring (27). Care should be taken when reassembling to install gasket (25) in bottom of

automatic drain before placing in bowl.

Should it be necessary to remove the manual drain assembly, unscrew drain cock (28) from the insert (24), then unscrew the retaining ring (27) from the insert, and remove the insert (24) itself.

**INSPECT EACH PART CAREFULLY. CAUTION: CLEAN ONLY IN CLEAR, WARM WATER OR KEROSENE. DO NOT ATTEMPT TO CLEAN THE AUTO-MATIC DRAIN MECHANISM OR FLOAT ASSEMBLY.**

If any parts are damaged, repair kits and replacement parts should be ordered from the Norgren Distributor in your area using the illustrated parts breakdown as a guide.

When reassembling, put a light coat of grease on the "O" ring on the valve assembly (11).

BOWL GUARD & MOUNTING BRACKET

To install bowl guard first slide bowl guard onto the body aligning the guard and body retainer spring grooves. Next insert the end of the retainer spring and by rotating the bowl guard around the body; "wind in" the spring to its installed position. See below.

Mounting bracket 5203-01 includes bracket only and is secured with a panel mount nut.

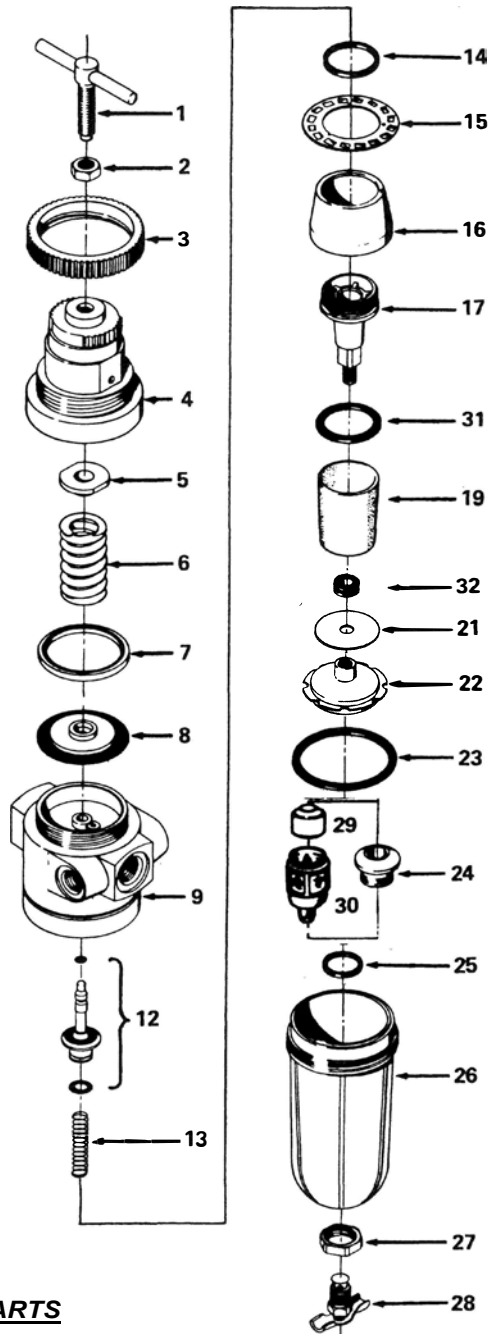
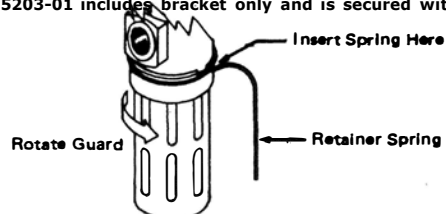

**PARTS**

**REPAIR KITS**

Non-relieving (25 & 50 Micron) (Incl. 8,12,14,23,25) . . . . .	5304-01
Non-relieving (5 Micron) (Incl. 8,12,14,23,25,31,32) . . . . .	5304-02
Relieving (25 & 50 Micron) (Incl. 8,12,14,23,25) . . . . .	5304-03
Relieving (5 Micron) (Incl. 8,12,14,23,25,31,32) . . . . .	5304-04
SPRING: 50 psig . . . . .	5302-02
125 psig . . . . .	5354-02
175 psig . . . . .	578-01

**"DESIGNER" SERIES MICRO-FOG LUBRICATOR**  
**1/4" & 3/8" PIPE SIZES (PATENT PENDING)**

**OPERATION**

The airline lubricator is a dynamic device. Oil is delivered into the compressed airline only when air is flowing through the lubricator.

A portion of the air is directed into oil reservoir (2) through fog generator (A). The remaining air flows around the flow sensor (9) to the downstream system.

Velocity of the air through the fog generator creates a low pressure area sensed in the sight feed dome (6). As a result, oil flows up the siphon tube (12) to the sight feed dome and drips into the fog generator (A).

The oil meets the high velocity air in the fog generator and generates oil fog in the upper portion of the reservoir. Most oil particles larger than 2 micron settle back in the reservoir. The smaller particles remain airborne and travel through passageway (C) into the downstream airline and on to its points of lubrication. These small oil particles are Micro-Fog.

The flow sensor deflects proportionally to air flow demand and governs Micro-Fog generation. This results in the lubricant being injected into the airline proportioned to air flow regardless of flow variations.

An oil feed adjusting knob is on the top of the lubricator. Rotating oil feed adjusting knob counter-clockwise increases the drip rate. Once the setting is established, the lubricator will automatically adjust drip rate with changes in flow. The oil feed setting can be "locked" by pushing red lock ring down. The lock must be released by pulling up before oil feed adjustment can be made.

**SPECIFICATIONS**

PIPE SIZES: 1/4", 3/8"

OIL RESERVOIR: 1/3-PINT TRANSPARENT POLYCARBONATE (STANDARD)  
 3-OZ. TRANSPARENT POLYCARBONATE (OPTIONAL)

MAXIMUM RECOMMENDED OPERATING CONDITIONS:  
 150 PSIG AT 125°F. AMBIENT

SUGGESTED LUBRICANT: THIS LUBRICATOR WILL PERFORM SATISFACTORILY USING LUBRICANT WITH VISCOSITY OF 150-200 S.S.U. AT 100°F. WE RECOMMEND THE USER OBTAIN LUBRICANT RECOMMENDATIONS FROM EQUIPMENT BUILDER AND LUBRICANT SUPPLIER.

OPERATING RANGE:

LOW-FLOW VERSION, 1/2 SCFM TO 10 SCFM AT 100 PSI (1/4" ONLY)

3/8" STANDARD, 3 SCFM TO 40 SCFM AT 100 PSI

1/4" STANDARD, 2 SCFM TO 20 SCFM AT 100 PSI

**CAUTION**

THIS LUBRICATOR SHOULD NOT BE USED IN APPLICATIONS WHICH MAY EXCEED MAXIMUM RECOMMENDED OPERATING CONDITIONS. DURING MAINTENANCE PERIODS INSPECT AND CLEAN EACH PART CAREFULLY, USING ONLY CLEAR, WARM WATER OR KEROSENE. DO NOT USE SOLVENTS AS THE POLYCARBONATE BOWL MAY BE DAMAGED.

**INSTALLATION**

Install in air line as close as possible to air operated devices to be lubricated. Installation of an air line filter ahead of the lubricator is recommended.

Fill reservoir with a good quality lubricant (see Specifications) and observe maximum fill line. **Do Not Overfill.** Space in the reservoir is necessary for fog generation.

**DIMENSIONS**

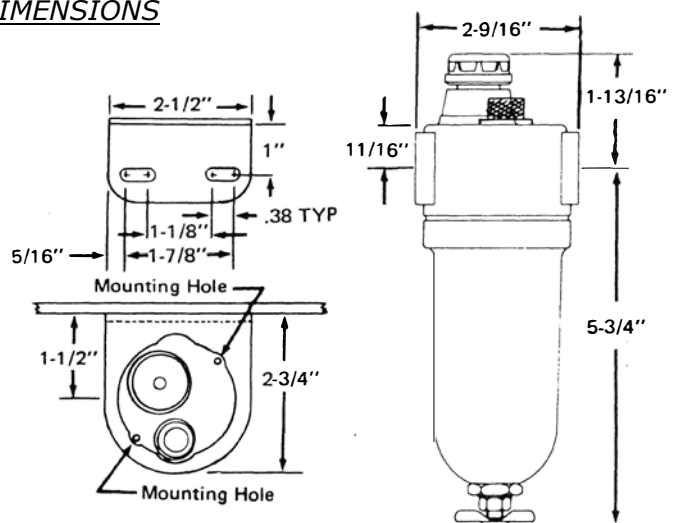

MAINTENANCE

Shut off the air pressure. Remove the sight feed dome (6), gasket (7), and reservoir (2). During maintenance periods, clean and inspect each part carefully, using only clear, warm water or kerosene as a cleansing agent. Do not remove the flow sensor unless obviously damaged.

PARTS

3.	Gasket . . . . .	2811-32
4.&5.	Fill plug with gasket . . . . .	1206-50
6.	Sight dome assembly . . . . .	5055-50
2.	Bowls: Trans., 1/3-Pint with drain . . . . .	3155-55
	Trans., 1/3-Pint, closed bottom . . . . .	3150-04
	Trans., 3-Oz., with drain . . . . .	3796-52
	Trans., 3-Oz., closed bottom . . . . .	3796-03
7.	"O" ring . . . . .	2315-19
8.	"O" ring . . . . .	2315-13

ACCESSORIES

Bowl Guard (Includes retainer spring)	5176-02
Mounting bracket	5203-02

GRAPHIC SYMBOL

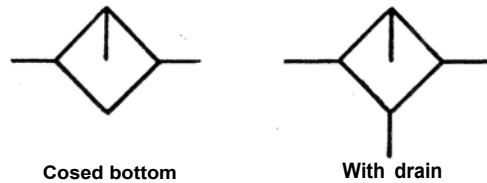

BOWL GUARD & MOUNTING BRACKET

To install bowl guard first slide bowl guard onto the body, aligning the guard and body retainer spring grooves. Next insert the end of the retainer spring and by rotating the bowl guard around the body, "wind in" the spring to its installed position. See below.

The 5203-02 mounting bracket kit includes bracket and self-tapping screws for panel mounting. See below.

