

# GB50

## PNEUMATIC INSTALLATION TOOL

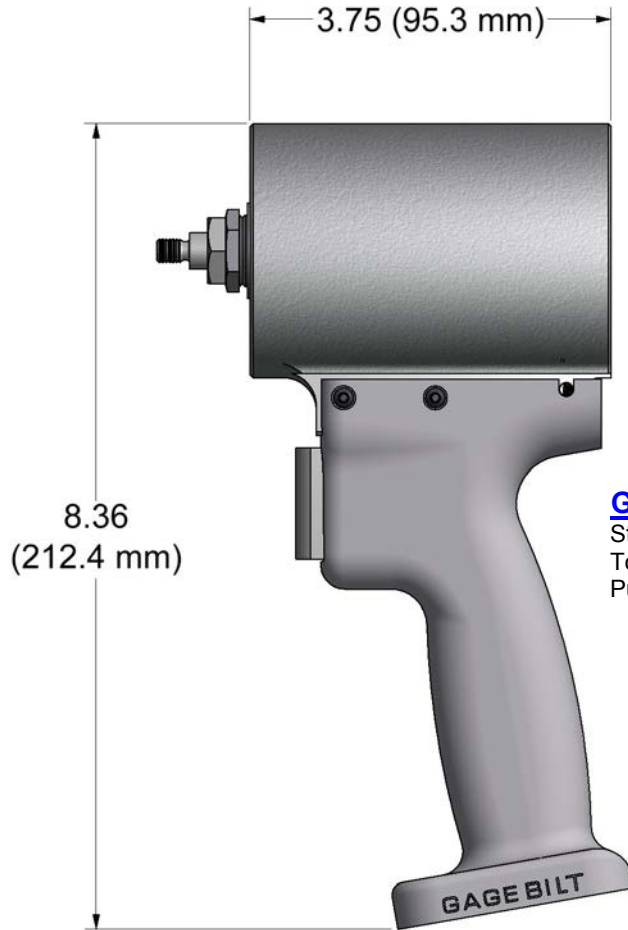

### GB50

Stroke - 0.740" (18.8 mm)  
Tool weight - 1.80 lbs. (0.82 kg)  
Pull load - 700 lbs. (3.11 kN)

### DESCRIPTION

The GB50 pneumatic riveter is designed specifically for the most efficient installation of blind rivets. It will in-install aluminum rivets through 5/32" diameter, and through 1/8" diameter rivets in any material. It weighs only 1.80 lbs. (0.82 kg) and can be operated in any position.

The GB50 Riveter is 8.36" high, has a 0.740" (18.8 mm) stroke and generates a minimum of 700 lbs. (3.11 kN) pull load at 90 psi (6.2 bar). It operates on 90 to 100 psi (6.2-6.9 bar) of air pressure at the tool.



Effective FOD Control (foreign object damage/debris). Install catcher bag on the front of the riveter to catch spent pintail stems. Place nose assembly through grommet on catcher bag and easily fasten catcher bag to tool using the Velcro strap. Features an easily emptied zippered pouch.

*Use catcher bag 500610 for XX-51-46 straight nose assemblies.  
Use catcher bag 715610 for XX-715-43 straight nose assemblies.*

**NOSE ASSEMBLIES AND CATCHER BAGS ARE NOT FURNISHED WITH THIS TOOL AND MUST BE PURCHASED SEPARATELY.**

**GAGE BILT**  
 **MADE in USA**



**INNOVATIVETOOLING**

*On the leading edge of Aircraft Tooling*

 800-832-7009

 sales@innovativetooling.com

 innovativetooling.com



## GB50 NOSE ASSEMBLY SELECTION CHART

### ACCESSORIES

#### Riveter Kits Available

Contact Gage Bilt to create your own custom kit  
(Sold Separately)



#### Alternative Option

GB54B Pneumatic Riveter  
With stem collection bottle  
for FOD control  
(Sold Separately)



See GB54B nose assembly selection chart for  
GB54B nose assemblies

**STRAIGHT**  
(Sold Separately)

**RIGHT ANGLE**  
(Sold Separately)

**OFFSET**  
(Sold Separately)



FASTENER	DIA.	STRAIGHT	RIGHT ANGLE <sup>1</sup>	OFFSET
NUT PLATE RIVETS MS20600 SERIES CCR244/264/274 MS/9SP/PT BACR15CC/CF/DA/DR	3/32 1/8 5/32 <sup>2</sup>	3C-715B-43 4C-715B-43 5C-715B-43	3C-715A-54RA 4C-715A-54RA 5C-715A-54RA	3C-715A-40OS 4C-715A-40OS 5C-715A-40OS
"A" CODE NAS1398A, NAS1399A NAS1738A, NAS1739A	3/32 1/8 5/32 <sup>2</sup>	3A-715B-43 4A-715B-43 5A-715B-43	3A-715A-54RA 4A-715A-54RA 5A-715A-54RA	3A-715A-40OS 4A-715A-40OS 5A-715A-40OS
<b>BLIND RIVET (SINGLE ACTION) WITH OR W/OUT DRIVE WASHER</b> NAS1900 S & U SERIES	1/8 5/32 <sup>2</sup>	SMLS04-715B-43 SMLS05-715B-43	SMLS04-715A-54RA SMLS05-715A-54RA	SMLS04-715B-40OS SMLS05-715B-40OS
MBC® NAS1715-1721	1/8 5/32 3/16	MBC04-715C-43 MBC05-715C-43 MBC06-715C-43		
OPEN END NAIL RIVET	3/32 1/8 <sup>3</sup> 5/32 <sup>2</sup>	3N-715E-43 4N-715E-43 5N-715E-43	3N-715A-54RA 4N-715A-54RA 5N-715A-54RA	3N-715A-40OS 4N-715A-40OS 5N-715A-40OS
CLOSED END NAIL RIVET (ALUMINUM MANDREL)	3/32 1/8 5/32	3N-715E-43 4CEA-715E-43 5CEA-715E-43	3N-715A-54RA 4CEA-715-54RA 5CEA-715-54RA	3N-715A-40OS 4CEA-715-40OS 5CEA-715-40OS
CLOSED END NAIL RIVET (STEEL MANDREL)	3/32 1/8 5/32	3N-715E-43 4CES-715E-43 5CES-715E-43	3N-715A-54RA 4CES-715-54RA 5CES-715-54RA	3N-715A-40OS 4CES-715-40OS 5CES-715-40OS
FASTACK® AF5022 AF5055	3/32 1/8 5/32	3C-715B-43 4C-715B-43 5C-715B-43	3C-715A-54RA 4C-715A-54RA 5C-715A-54RA	3C-715A-40OS 4C-715A-40OS 5C-715A-40OS
SUPERTACK® AF5075 AF5076 S149A020	1/8 5/32	3A-715B-43 4A-715B-43	3A-715A-54RA 4A-715A-54RA	3A-715A-40OS 4A-715A-40OS

MBC® IS A REGISTERED TRADEMARK OF CHERRY AEROSPACE. FASTACK® AND SUPERTACK® ARE REGISTERED TRADEMARKS OF ALLFAST FASTENING SYSTEMS INC.

#### GAGE BILT CERTIFIES THE GB50 WILL INSTALL THE ABOVE FASTENERS

1) RIGHT ANGLE NOSE ASSEMBLYS MAY REQUIRE MORE THAN ONE PULL.
2) ALUMINUM ONLY.
3) ALUMINUM & STEEL ONLY.
*ALL COUNTERSUNK 'C' NOSE ASSEMBLYS MAY BE USED TO INSTALL BOTH UNIVERSAL & COUNTERSUNK HEAD RIVETS

NOTE: THE LAST 2 DIGITS OF THE NOSE ASSEMBLY REPRESENTS THE LENGTH THE NOSE  
EXTENDS FROM THE TOOL. I.E. -20 = 2.0 INCHES

Grip Gage for NAS LOCKBOLTS  
and blind fasteners  
**#GB105093**  
(Sold Separately)



Grip Gage for CHERRYMAX®  
and CHERRYLOCK® rivets  
**#269G3**  
(Sold Separately)

