

ORIGINAL INSTRUCTIONS

S/N: 1727 AND ABOVE  
PLEASE CONTACT GAGE BILT FOR  
ALL OTHER SERIAL NUMBERS.

# GB50

## PNEUMATIC INSTALLATION TOOL



**GAGE BILT**  
 **MADE in USA**



**INNOVATIVETOOLING**  
*On the leading edge of Aircraft Tooling*

 800-832-7009

 [sales@innovativetooling.com](mailto:sales@innovativetooling.com)

 [innovativetooling.com](http://innovativetooling.com)

# TABLE OF CONTENTS



<b>EU Conformity and Warranty .....</b>	<b>3</b>
<b>Description and Technical Specifications .....</b>	<b>4</b>
<b>Description of Functions .....</b>	<b>5</b>
<b>Warnings.....</b>	<b>6</b>
<b>Principle of Operation .....</b>	<b>7</b>
<b>How to set-up the GB50.....</b>	<b>8</b>
<b>How to use the GB50 .....</b>	<b>9</b>
<b>Maintenance .....</b>	<b>10</b>
<b>Troubleshooting .....</b>	<b>11</b>
<b>Overhaul .....</b>	<b>12</b>
<b>Parts Lists.....</b>	<b>13</b>
<b>Nose Assembly Selection Chart / Accessories .....</b>	<b>14-16</b>

## DECLARATION OF CONFORMITY

**MANUFACTURER:** Gage Bilt Inc. 44766 Centre Ct. Clinton Twp. Michigan U.S.A. +1 (586-226-1500)

**WE DECLARE THAT THE EQUIPMENT SPECIFIED HEREIN CONFORMS TO THE FOLLOWING DIRECTIVES AND STANDARDS**

Machinery Directive 2006/42/EC

EN12100-1 & EN12100-2

EN792-1:2000+A1

**EU REPRESENTATIVE:** Edgar Hausmann GmbH Förster-Busch-Str. 10 D-34346 Hann. Münden Germany

**EQUIPMENT DESCRIPTION:** GB50 FASTENER INSTALLATION TOOL

This product specified above conforms to the above directives and standards.

SIGNATURE:



NAME: BRIAN LEIGH  
PRODUCT MANAGER  
CLINTON TWP., MI U.S.A.  
MAY 2010  
+1 (586) 226-1500

### WARRANTY

Seller warrants that all goods covered by this catalog will conform to applicable specifications and will replace or repair, EXW our plant, any goods providing defective from faulty workmanship, or material, for 1 year from date of shipment.

Said warranty to remain in effect if, and only if, such goods are used in accordance with all instructions as to maintenance, operation and use, set forth in manuals and instruction sheets furnished by seller.

Sellers obligation under this warranty shall be limited to the repair or rework of the goods supplied or replacement thereof, at Seller's option, and in no case is to exceed the invoice value of said goods. Under no circumstances will the seller be liable for incidental or consequential damages or for damages incurred by the buyer or subsequent user in repairing or replacing defective goods or if the goods covered by this warranty are reworked or subjected to any type of additional processing.

This warranty is void if Seller is not notified in writing of any rejections or defects within 1 year after the receipt of the material by the customer.

**THIS WARRANTY IS MADE IN LIEU OF ALL OTHER WARRANTIES EXPRESSED OR IMPLIED, INCLUDING MERCHANTABILITY.**

## DESCRIPTION



**⚠ WARNING:** Any other use is forbidden.

The GB50 pneumatic installation tool is designed specifically for the most efficient installation of blind rivets. It will install aluminum fasteners through 5/32" diameter, and through 1/8" diameter fasteners in any material. It weighs only 1.8 lbs. (0.82 kg) and can be operated in one hand.

The GB50 Installation tool is 8.36" (212.4 mm) high, has a .740" (18.8mm) stroke and generates a minimum of 700 lbs. (3.11 kN) pull load at 90 psi (6.2 bar). It operates on 90 psi-100 psi (6.2 bar-6.9 bar) of air pressure, with 90 psi. (6.2 bar) providing maximum efficiency. At 90 psi. (6.2 bar) of air pressure, the GB50 does not exceed 81.5 dB(A) and consumes .29 SCF/cycle (8.21 L/cycle).

The air inlet is provided with 1/4-18 female pipe thread to accept the users air hose fitting.

**NOSE ASSEMBLIES ARE NOT FURNISHED WITH THIS TOOL AND MUST BE PURCHASED SEPARATELY.** (See nose assembly selection chart on pg. 14).

## ENVIRONMENTAL USE

**⚠ WARNING:** Do not operate in an explosive atmosphere.

The GB50 can be operated between 0°F - 118°F (-17.8°C / 47.8°C)

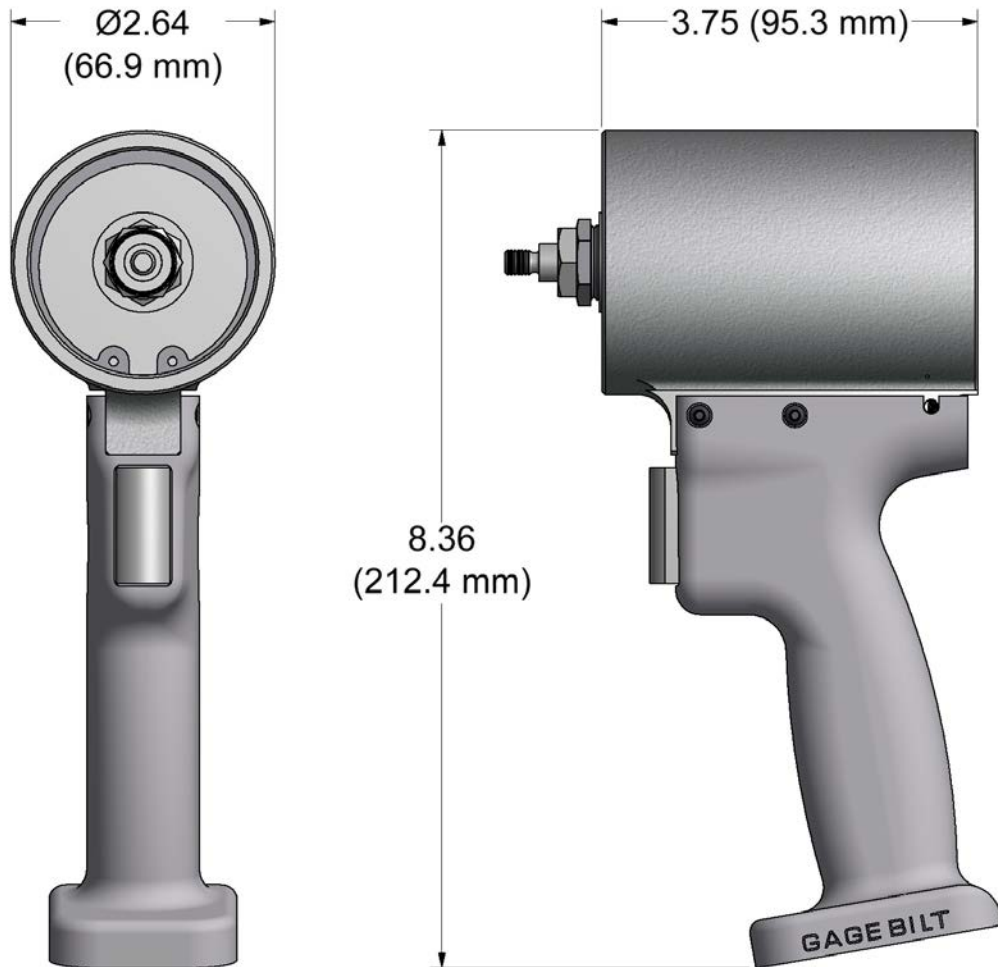

## SPECIFICATIONS

Hand Held Weight	- 1.80 lbs. (0.82 kg)
Air pressure req'd	- 90-100 p.s.i. (6.2-6.9 bar) Max.
Air consumption	- .29 SCF/cycle (8.21 L/cycle).
Setting stroke	- .740" (18.8 mm)
Noise level	- 81.5 dB (A)
Rated pull load	- 700 lbs. (3.11 kN)
Vibration	- Tested– No hazards found.

# DESCRIPTION OF FUNCTIONS

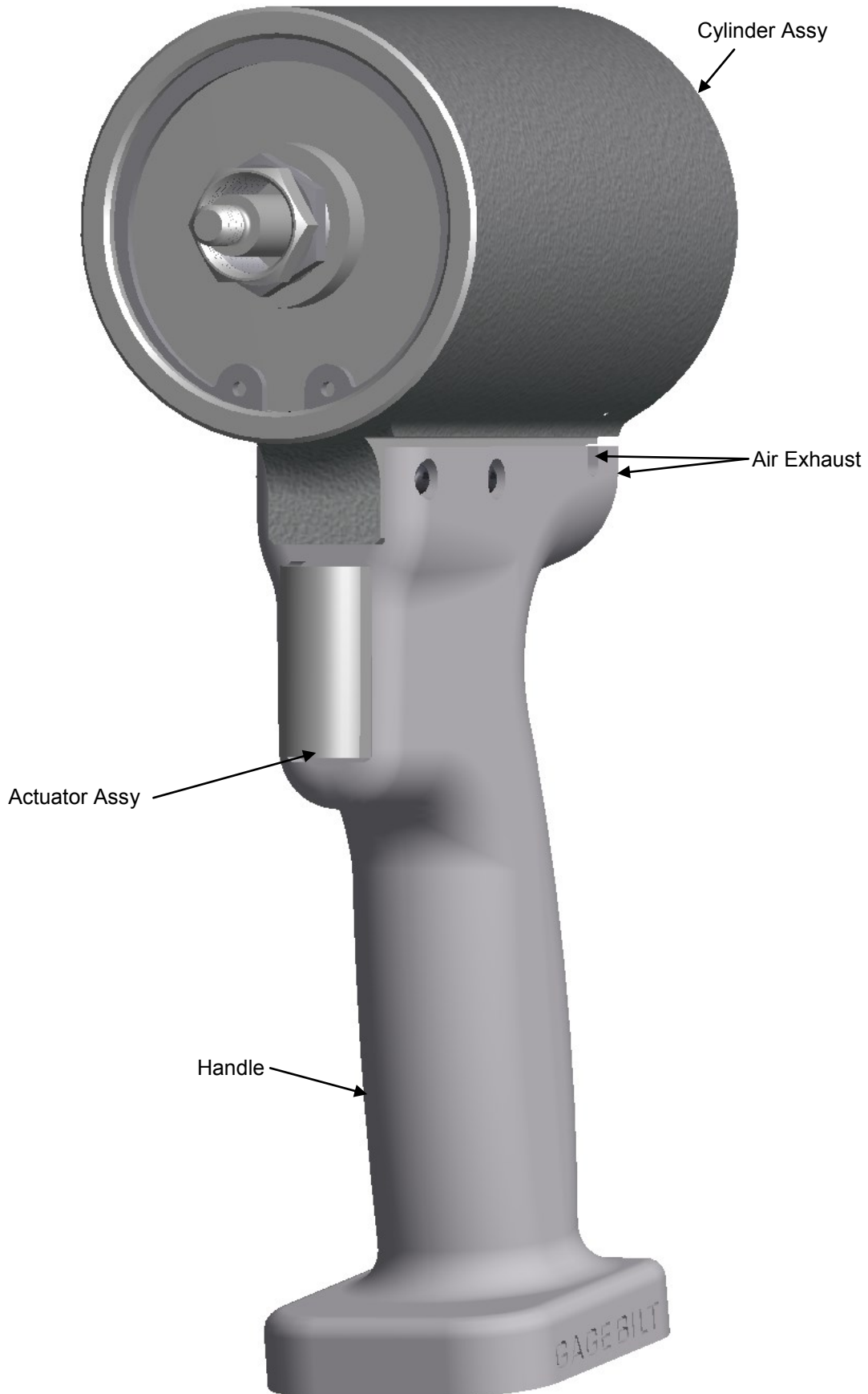

Image may not reflect actual tool



## TERMS AND SYMBOLS



- Product complies with requirements



- Read manual prior to using equipment



- Hearing protection and eye protection



- Wear safety boots



**WARNINGS** - Must be understood to avoid severe personal injury.



**CAUTIONS** - show conditions that will damage equipment and/or structure.

**Notes** - are reminders of required procedures.

## GENERAL SAFETY RULES:

1. For multiple hazards, read and understand the safety instructions before installing, operating, repairing, maintaining, changing accessories on, or working near the assembly power tool for non-threaded mechanical fasteners.
2. Only qualified and trained operators should install, adjust or use the assembly power tool for non threaded mechanical fasteners.
3. Do not modify this assembly power tool for non-threaded mechanical fasteners. Modifications can reduce effectiveness of safety measures and increase the risks to the operator.
4. Do not discard safety instructions; give them to the operator.
5. Do not use assembly power tool for non-threaded mechanical fasteners if it has been damaged.
6. Tools shall be inspected periodically to verify all ratings and markings required are legible. The employer/user shall contact the manufacturer to obtain replacement marking labels when necessary.
7. Air under pressure can cause severe injury.
8. Always shut off air supply, drain hose of air pressure and disconnect tool from air supply when not in use, before changing accessories or when making repairs.
9. Never direct air at yourself or anyone else.
10. Whipping hoses can cause severe injury. Always check for damage or loose hoses and fittings.
11. Cold air shall be directed away from hands.
12. Whenever universal twist couplings (claw couplings) are used, lock pins shall be installed and whipcheck safety cables shall be used to safeguard against possible hose-to-tool or hose-to-hose connection failure.
13. Do not exceed the maximum air pressure stated on the tool or manual.
14. Never carry an air tool by the hose.

## ADDITIONAL SAFETY RULES FOR PNEUDRAULIC POWER TOOLS:

1. Air under pressure can cause severe injury.
2. Always shut off air supply, drain hose of air pressure and disconnect tool from air supply when not in use, before changing accessories or when making repairs.
3. Never direct air at yourself or anyone else.
4. Whipping hoses can cause severe injury. Always check for damage or loose hoses and fittings.
5. Cold air shall be directed away from hands.
6. Whenever universal twist couplings (claw couplings) are used, lock pins shall be installed and whipcheck safety cables shall be used to safeguard against possible hose-to-tool or hose-to-hose connection failure.
7. Do not exceed the maximum air pressure stated on the tool or manual.
8. Never carry an air tool by the hose.

## PROJECTILE HAZARDS:

1. Disconnect the tool from the energy source when changing inserted tools/nose assemblies or accessories.
2. Be aware that failure of the workpiece or accessories, or even the inserted tool/nose assembly itself can generate high-velocity projectiles.
3. Always wear impact resistant eye protection during operation of the tool. The grade of protection required should be assessed for each use.
4. The risk to others should also be assessed at this time.
5. Ensure that the workpiece is securely fixed.
6. Check that the means of protection from ejection of fastener and/or stem is in place and operative (such as the deflector).
7. Forcible ejection of the mandrel from the front of the nose assembly is possible.

## OPERATING HAZARDS:

1. Use of tool can expose the operator's hands to hazards, including crushing, impacts, cuts, abrasions and heat. Wear suitable gloves to protect hands.
2. Operators and maintenance personnel shall be physically able to handle the bulk, weight and power of the tool.
3. Hold the tool correctly; be ready to counteract normal or sudden movements and have both hands available.
4. Maintain a balanced body position and secure footing.
5. Release the start-and-stop device in the case of interruption of energy supply.
6. Use only lubricants recommended by the manufacturer.
7. Avoid unsuitable postures as it is likely for these positions not to allow counteracting of normal or unexpected movement of the tool.
8. If the tool is fixed to a suspension device, make sure that fixation is secure.
9. Beware of the risk of crushing or pinching if nose equipment is not fitted.
10. Due to the tool weight, it is recommended safety shoes be worn during operation.
11. It is recommended tool be operated not more than 50 out of every 60 minutes, where prolonged use is expected.

## REPETITIVE MOTIONS HAZARDS:

1. When using the tool, the operator can experience discomfort in the hands, arms, shoulders, neck or other parts of the body.
2. While using the tool, the operator should adopt a comfortable posture while maintaining a secure footing and avoiding awkward or off balanced postures. The operator should change posture during extended tasks; this can help avoid discomfort and fatigue.
3. If the operator experiences symptoms such as persistent or recurring discomfort, pain, throbbing, aching, tingling, numbness, burning sensations or stiffness, these warning signs should not be ignored. The operator should tell the employer and consult a qualified health professional.

## ACCESSORY HAZARDS:

1. Disconnect tool from energy supply before changing the nose assembly or accessory.
2. Use only sizes and types of accessories recommended by the manufacturer. Do not use other types or sizes of accessories.

## WORKPLACE HAZARDS:

1. Slips, trips and falls are major causes of workplace injury. Be aware of slippery surfaces caused by use of tool and also of trip hazards caused by the air line or hydraulic hose.
2. Proceed with care in unfamiliar surroundings. There could be hidden hazards, such as electricity or other utility lines.
3. The tool is not intended for use in potentially explosive atmospheres and is not insulated against contact with electrical power.
4. Ensure that there are no electrical cables, gas pipes, etc., which can cause a hazard if damaged by the tool.

## NOISE HAZARDS:

1. Exposure to high noise levels can cause permanent, disabling hearing loss and other problems, such as tinnitus (ringing, buzzing, whistling or humming in the ears). Therefore, risk assessment and the implementation of appropriate controls for these hazards are essential.
2. Appropriate controls to reduce the risk may include actions such as damping materials to prevent workpieces from "ringing".
3. Use hearing protection in accordance with employer's instructions and as required by occupational health and safety regulations.
4. Operate and maintain the assembly power tool for non-threaded mechanical fasteners as recommended in the instruction handbook, to prevent an unnecessary increase in the noise level.
5. Select, maintain and replace the consumable/inserted tool as recommended in the instruction handbook, to prevent an unnecessary increase in noise.
6. If the power tool has a silencer, always ensure that it is in place and in good working order when the power tool is being operated.

## VIBRATION HAZARDS:

1. Exposure to vibration can cause disabling damage to the nerves and blood supply of the hands and arms.
2. Wear warm clothing when working in cold conditions and keep your hands warm and dry.
3. If you experience numbness, tingling, pain or whitening of the skin in your fingers or hands, stop using the assembly power tool for non-threaded mechanical fasteners, tell your employer and consult a physician.
4. Support the weight of the tool in a stand, tensioner or balancer, because a lighter grip can then be used to support the tool.

## PRINCIPLE OF OPERATION



When the actuator assy (1) (510127) is depressed, the pressurized air inside the tool is directed to the front side of the piston (3) (510101) thus moving it to the rear of the cylinder assy (2) (500119), forcing the air from the back side of the piston (3) (510101) to be exhausted from the side of tool. The internal components of the attached nose assembly are simultaneously moving with the piston (3) (510101) to start the fastener installation. When the fastener installation is completed, the actuator assy (1) (510127) is released directing the air to the back side of the piston (3) (510101) reversing the sequence.

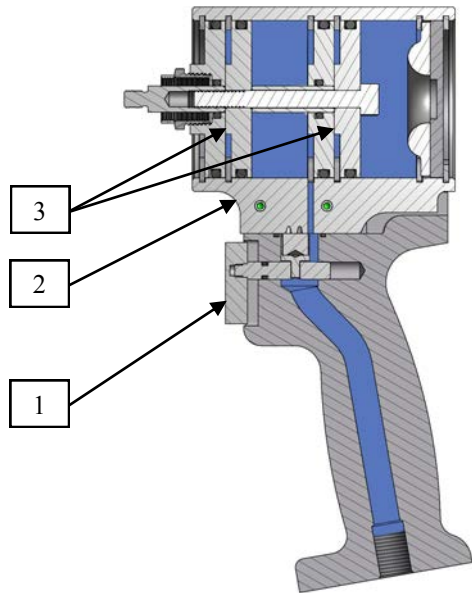

Piston in forward position

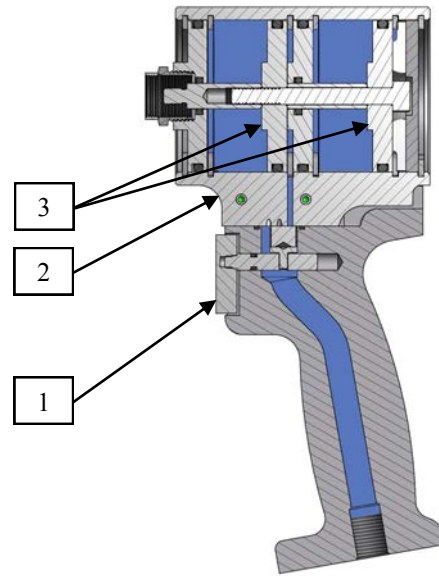

Piston in rear position

## AIR EXHAUST

Air is exhausted through the standard exhaust port on the side of the tool. To redirect air exhaust to rear of tool, remove plug (401816) from rear exhaust hole. If changing exhaust back to side, we recommend applying Vibra-tite® to plug (401816) before installation.

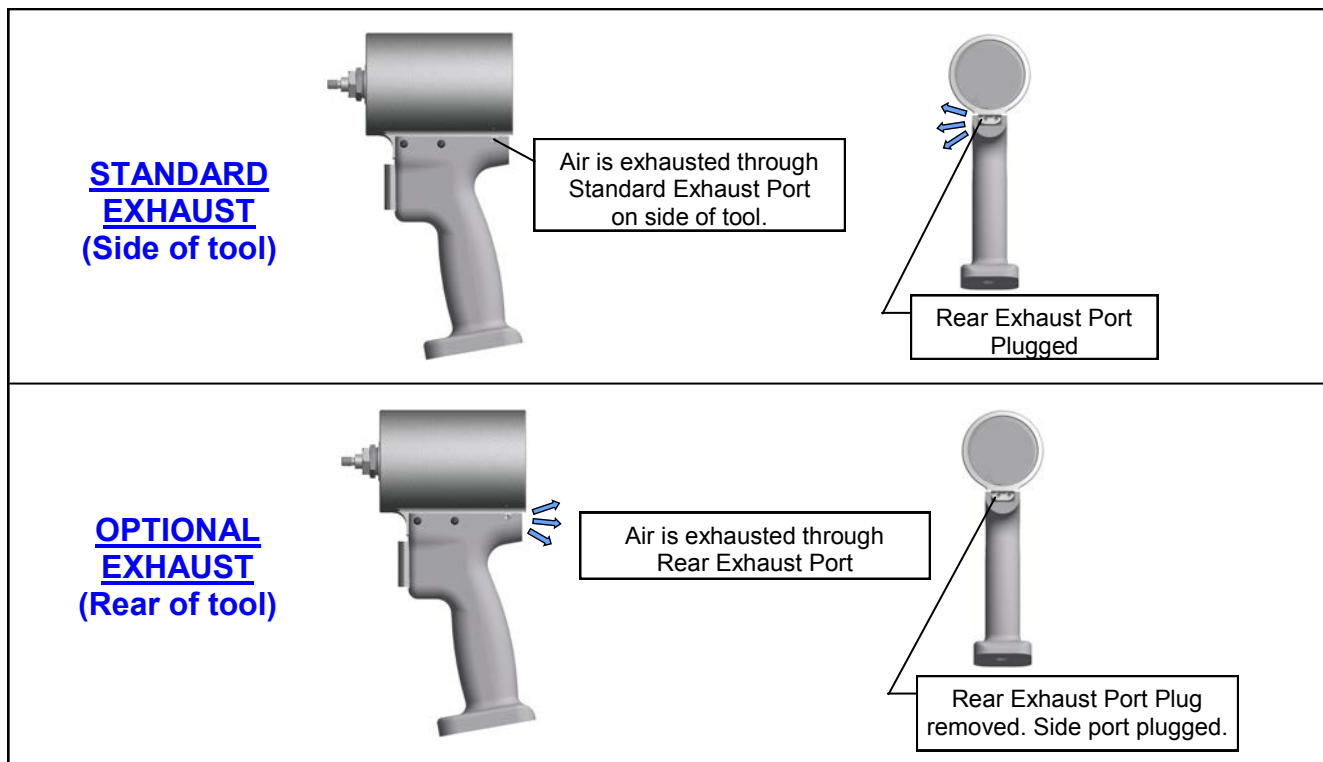

## HOW TO SET-UP THE GB50



- ⚠ WARNING:** Only qualified and trained operators should install, adjust or use the assembly power tool for non-threaded mechanical fasteners.
- ⚠ WARNING:** Operator **MUST** read and understand all warnings and cautions.
- ⚠ WARNING:** It is required that eye protection, hearing protection and safety boots be worn at all times while handling this equipment.
- ⚠ WARNING:** The users or the user's employer should assess specific risks that could be present as a result after each use based on their application.
  - *Be sure there is adequate clearance for tool and operator's hands before proceeding. Keep fingers clear of any moving parts. Keep fingers clear from fasteners and installed materials. Severe personal injury may result.*
  - *Verify the airlines and/or hydraulic hoses are not a trip hazard.*
  - *Ensure that there are no electrical cables, gas pipes, etc., which can cause a hazard if damaged by the tool*
- ⚠ WARNING:** Do not pull fastener in the air. Personal injury from fastener ejecting may occur.
- ⚠ WARNING:** Air is exhausted from the side of the tool. Direct side of the tool (exhausted air) away from operator, other persons working in the vicinity, foreign matter and liquid.
- ⚠ WARNING:** Do not carry from hoses or use as a hammer.
- ⚠ WARNING:** Do not use in explosive atmosphere.
- ⚠ WARNING:** Ensure air hose is securely connected to avoid possible hose whipping.
- ⚠ WARNING:** Always disconnect air supply when tool is not in use to prevent accidental start-up.
- ⚠ WARNING:** Be sure there is adequate clearance for tool and operator hands.
- ⚠ CAUTION:** Do not use beyond the design intent.

The tool is shipped with a plastic plug in the air inlet connector. The connector has a 1/4-18 female pipe thread to accept end-user air hose fitting. Air is exhausted through a port in the side of the tool. To redirect air exhaust to rear of tool, remove plug (401816) from rear exhaust hole. If changing exhaust back to side, we recommend applying Vibra-tite® to plug (401816) before installation. (See page 7 for air exhaust options.)

1. Remove red plastic shipping plug from handle (510422) and install 1/4" air fitting into bottom of handle (510422). Only use an air supply set at 90 psi (6.2 bar)-100 psi (6.9 bar) equipped with a filter-regulator to prevent wear.
2. Connect tool to air hose with 90 psi. (6.2 bar) using clean, dry air. 3/8 minimum diameter air line is recommended. Cycle tool a few times by depressing and releasing actuator assy (510127).
3. Disconnect air hose from tool.
4. Select proper Nose Assembly, screw collet and anvil onto the tool and attach securely. (See proper data sheet for further instructions.)
5. Connect air supply.
6. **To install screw-on pulling head:** While keeping internal components of pulling head forward in the nose assembly start threading in the anvil holder, continue threading in until internal component starts to thread onto the drawbolt (510217). Thread nose assembly in until nose assembly bottoms out. After nose assembly is completely threaded onto tool, back off nose until the flat is in the desired position and tighten locknut. For nose assemblies with a pintail ejection slot we recommend locating it down so used fastener stems fall out of the nose assembly by gravity. .



Effective FOD Control (foreign object damage/debris). Install catcher bag on the front of the installation tool to catch spent pintail stems. Place nose assembly through grommet on catcher bag and easily fasten catcher bag to tool using the Velcro strap. Features an easily emptied zippered pouch.

*Use catcher bag-stem 715610 for XX-715-43 straight nose assemblies.*

**CATCHER BAGS ARE NOT FURNISHED WITH TOOLS AND MUST BE PURCHASED SEPARATELY.**

Image may not reflect actual tool





- ⚠ WARNING:** Only qualified and trained operators should install, adjust or use the assembly power tool for non-threaded mechanical fasteners.
- ⚠ WARNING:** Operator **MUST** read and understand all warnings and cautions.
- ⚠ WARNING:** It is required that eye protection, hearing protection and safety boots be worn at all times while handling this equipment.
- ⚠ WARNING:** The users or the user's employer should assess specific risks that could be present as a result after each use based on their application.
  - *Be sure there is adequate clearance for tool and operator's hands before proceeding. Keep fingers clear of any moving parts. Keep fingers clear from fasteners and installed materials. Severe personal injury may result.*
  - *Verify that hydraulic hose fittings and couplings, air and electrical connections are secure.*
  - *Verify the airlines and/or hydraulic hoses are not a trip hazard.*
  - *Ensure that there are no electrical cables, gas pipes, etc., which can cause a hazard if damaged by the tool.*
  - Do not use as a hammer to force fasteners into holes or otherwise abuse tool.
- ⚠ WARNING:** Do not pull fastener in the air. Personal injury from fastener ejecting may occur.
- ⚠ WARNING:** Do not carry from hoses or use as a hammer.
- ⚠ WARNING:** Do not use in explosive atmosphere.
- ⚠ CAUTION:** Do not use beyond the design intent.

### Blind Fasteners

1. Insert fastener.



2. Insert fastener into nose assembly.

**Note:** Always hold tool so pulling head is perpendicular to surface of material in which fastener is being installed. Exert firm pressure against fastener during installation.



3. Press actuator to start cycle.



4. Release actuator as soon as fastener breaks.
5. Repeat steps 1-4.

Images may not reflect actual tool or fastener

## DAILY MAINTENANCE



- ⚠ WARNING:** Tool must be maintained in a safe working condition at all times and examined on a daily basis for damage or wear. Any repair should be done by qualified personnel trained on Gage Bilt procedures.
- ⚠ WARNING:** Excessive contact with hydraulic oil and lubricants should be avoided.
- ⚠ WARNING:** Maintenance personnel **MUST** read and understand all warnings and cautions.
- ⚠ WARNING:** Disconnect tool from its power source before performing maintenance, cleaning or when replacing worn or damaged components. Severe personal injury may occur if power source is not disconnected.
- ⚠ WARNING:** Read SDS documents for all applicable materials.

### Note:

- All tool materials are recyclable except rubber o’rings, seals and wipers.

The performance of any tool depends upon good maintenance practices. Following these minimal requirements daily will extend the life of your tool.

- \*Only use a clean dry air supply set at 90-100 p.s.i. (6.2-6.9 bar) Max. with a filter-regulator to prevent wear.
- \* Check tool and nose assembly for damage. (Replace/Repair if necessary). See Overhaul (pg. 12) for tool repair.
- \* Inspect hoses and couplings for wear, damage and leaks. (Replace/Repair if necessary).
- \* Cycle the tool several times to assure there are no leaks during use.
- \* Proper care by operators is necessary in maintaining full productivity and reducing downtime.
- \* Keep nose assemblies, especially jaws, clean and free of chips and debris. Lube jaws and collet surfaces that jaws ride on with light machine oil on a daily basis.
- \* All Screwed End Caps, Base Covers, Air Fittings, Air Actuators, Screws and Nose Assemblies are to be examined at the end of each working shift to check that they are secure.
- \* A complete overhaul can be achieved by the use of Service Kit (500000) which contains a complete set of o’rings, retaining rings, screws, and pins. It is recommended that this service kit be kept available for spare parts.

SEE TROUBLESHOOTING (PG. 11) AND OVERHAUL (PG. 12) FOR FURTHER GUIDANCE.

## CLEANING AND LUBRICATING PROCEDURE

Daily cleaning and lubrication of nose assembly will greatly reduce downtime and increase life of components. Using sewing machine oil, or an equivalent cleaner/lubricant, follow instructions below.

### CLEANING

Clean nose assy daily or as often as needed.

1. Dip nose assy into mineral spirits or similar solvent to clean jaws and wash away metal chips and debris. **DO NOT** allow jaws to come in contact with other solvents. **DO NOT** let jaws soak. Dry jaws immediately.
2. Disassemble nose assy and use a sharp “pick” to remove embedded particles from grooves of jaws.

### LUBRICATING

Lubricate nose assy after each cleaning and as often as needed

1. Disconnect tool vacuum line (if equipped).
2. Point nose assembly into oil as shown.
3. Cycle tool 8-10 times and wipe dry.



Fig A.

Image may not reflect actual tool

## TROUBLESHOOTING



Providing all maintenance conditions have been met, follow this systematic approach to diagnosis.

1. MORE THAN ONE PULL IS REQUIRED TO BREAK FASTENER WHEN THE ACTUATOR ASSY (510127) IS DEPRESSED:
  - a) Jaws are stripped or packed with chips. Clean or replace.
  - b) Incorrect nose tip.
  
2. FASTENER STEM JAMMED IN NOSE ASSEMBLY:
  - a) Nose assembly components require service. **DISCONNECT AIR FROM TOOL**, remove the nose assembly from the tool and disassemble. Replace worn or broken parts. Clean the surface the jaws ride on.
  - b) Stems lodged side by side in the follower. Disassemble, remove stems, and reassemble.
  - c) Incorrect follower.

## OVERHAUL



**⚠ WARNING:** Disconnect tool from its air source before disassembly.

**⚠ CAUTION:** When replacing the dividers (510102), care should be taken to replace the retaining rings (S15) so they do not block the air ports at the bottom of the cylinder assy (500119) where the handle (510422) attaches. Use caution not to nick or score i.d. bore.

\* For a complete overhaul, service kit (500000) is recommended.

### HEAD

1. Using a Truarc® plier, remove retaining ring (S15) which allows removal of back cap (510118) and cushion (510114).
2. Double nut front end of drawbolt (510217) using 1/4-28 nut, then remove connector bolt (500120) permitting removal of retaining ring (S15) and rear piston (510101).
3. Remove front retaining ring (S15) and withdraw front seal (510119).
4. Remove the front piston (510101), permitting removal of the sleeve (510104). The double piston chambers are separated by dividers (510102) which may be removed by removing the retaining rings (S15).

The re-assembly sequence is the opposite of disassembly.

### HANDLE

#### For complete disassembly.

1. Remove two button head cap screws (A-819).
2. Slide out 2 dowel screws (510215).
3. Remove and replace o'ring (400782) & seal (510105).

Reassembly sequence is the opposite of disassembly. Note: When reassembling, seal seat (510125) inserts into hole on actuator assy (510127). (See image below).

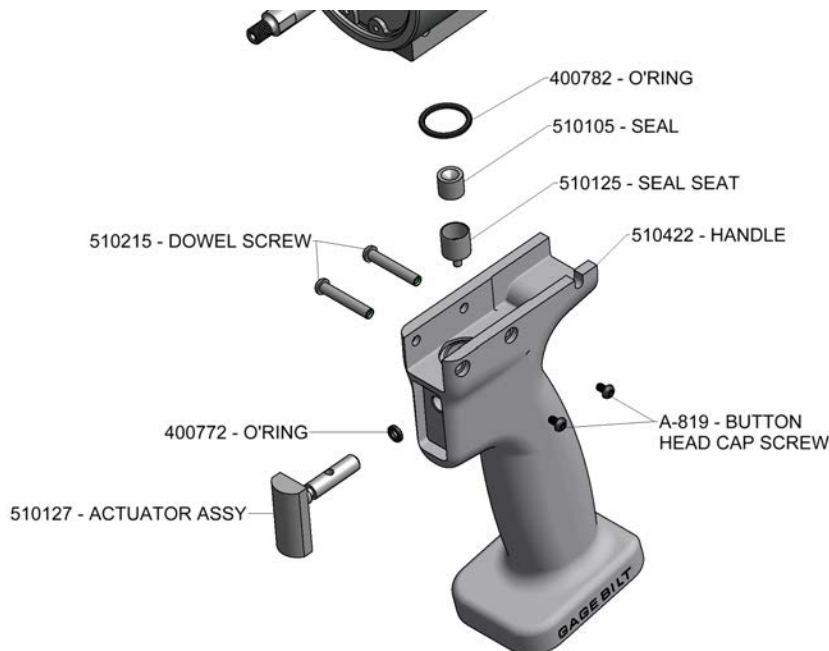

Seal Seat (510125) inserts into Actuator Assy (510127)  
(Note directions of assembled parts).

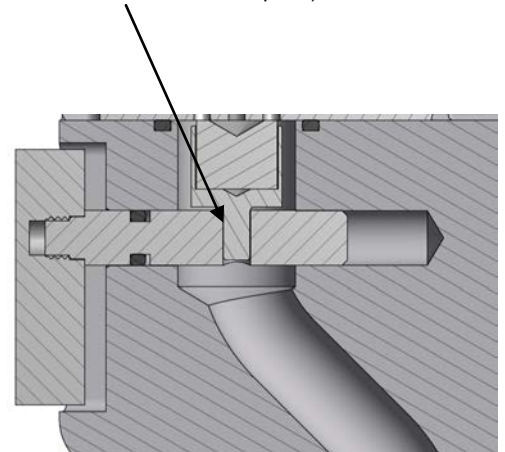

Images may not reflect actual tool

### TOOL DISPOSAL

1. When tool life is met, disassemble tool and remove all rubber o'rings, seals and wipers. All tool materials are recyclable except rubber o'rings, seals and wipers. Dispose of rubber materials in accordance with all environmental regulations applicable in your area.



# GB50 PARTS LIST



**INNOVATIVETOOLING**

*On the leading edge of Aircraft Tooling*

800-832-7009

sales@innovativetooling.com

innovativetooling.com

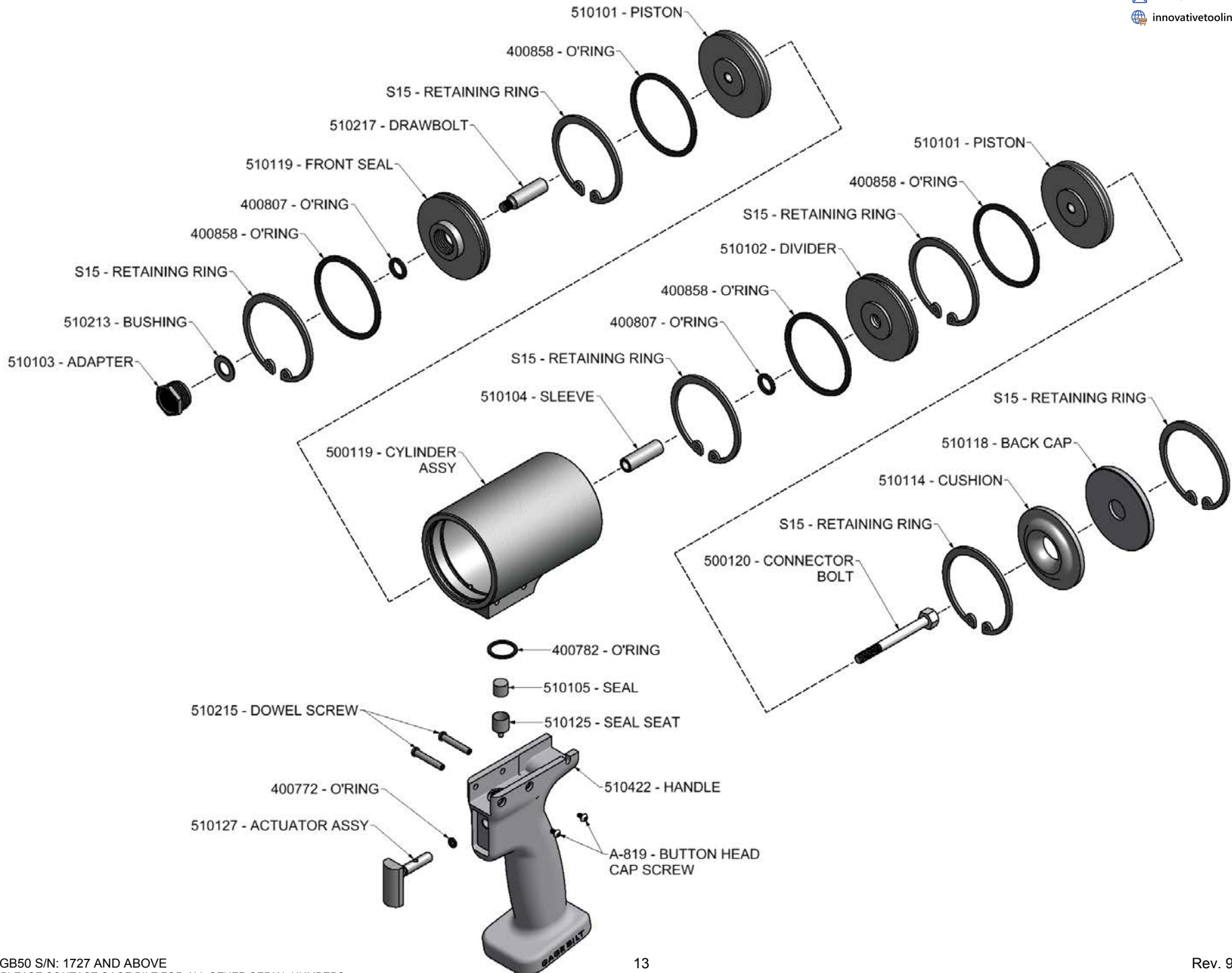

# ACCESSORIES



## GB50 NOSE ASSEMBLY SELECTION CHART

**STRAIGHT**  
(Sold Separately)

**RIGHT ANGLE**  
(Sold Separately)

**OFFSET**  
(Sold Separately)



### Catcher Bag-Stem (715610)

Effective FOD Control  
Use with **XX-715-43**  
straight nose assemblies.  
(Sold Separately)



Image may not reflect actual tool

### Grip Gage for NAS LOCKBOLTS and blind fasteners #GB105093 (Sold Separately)



FASTENER	DIA.	STRAIGHT	RIGHT ANGLE	OFFSET
NUT PLATE RIVETS MS20600 SERIES CCR244/264/274 MS/9SP/PT BACR15CC/CF/DA/DR	3/32 1/8 5/32 <sup>2</sup>	3C-715B-43 4C-715B-43 5C-715B-43	3C-715A-54RA 4C-715A-54RA 5C-715A-54RA	3C-715A-400S 4C-715A-400S 5C-715A-400S
"A" CODE NAS1398A, NAS1399A NAS1738A, NAS1739A	3/32 1/8 5/32 <sup>2</sup>	3A-715B-43 4A-715B-43 5A-715B-43	3A-715A-54RA 4A-715A-54RA 5A-715A-54RA	3A-715A-400S 4A-715A-400S 5A-715A-400S
<b>BLIND RIVET (SINGLE ACTION) WITH OR W/OUT DRIVE WASHER</b> NAS1900 S & U SERIES	1/8 5/32 <sup>2</sup>	SMLS04-715B-43 SMLS05-715B-43	SMLS04-715A-54RA SMLS05-715A-54RA	SMLS04-715B-400S SMLS05-715B-400S
MBC® NAS1715-1721	1/8 5/32 3/16	MBC04-715C-43 MBC05-715C-43 MBC06-715C-43		
OPEN END NAIL RIVET	3/32 1/8 <sup>3</sup> 5/32 <sup>2</sup>	3N-715E-43 4N-715E-43 5N-715E-43	3N-715A-54RA 4N-715A-54RA 5N-715A-54RA	3N-715A-400S 4N-715A-400S 5N-715A-400S
CLOSED END NAIL RIVET (ALUMINUM MANDREL)	3/32 1/8 5/32	3N-715E-43 4CEA-715E-43 5CEA-715E-43	3N-715A-54RA 4CEA-715A-54RA 5CEA-715A-54RA	3N-715A-400S 4CEA-715A-400S 5CEA-715A-400S
CLOSED END NAIL RIVET (STEEL MANDREL)	3/32 1/8 5/32	3N-715E-43 4CES-715E-43 5CES-715E-43	3N-715A-54RA 4CES-715A-54RA 5CES-715A-54RA	3N-715A-400S 4CES-715A-400S 5CES-715A-400S
FASTACK® AF5022 AF5055	3/32 1/8 5/32	3C-715B-43 4C-715B-43 5C-715B-43	3C-715A-54RA 4C-715A-54RA 5C-715A-54RA	3C-715A-400S 4C-715A-400S 5C-715A-400S
SUPERTACK® AF5075 AF5076 S149A020	1/8 5/32	3A-715B-43 4A-715B-43	3A-715A-54RA 4A-715A-54RA	3A-715A-400S 4A-715A-400S

MBC® IS A REGISTERED TRADEMARK OF CHERRY AEROSPACE. FASTACK® AND SUPERTACK® ARE REGISTERED TRADEMARKS OF ALLFAST FASTENING SYSTEMS INC.

### GAGE BILT CERTIFIES THE GB50 WILL INSTALL THE ABOVE FASTENERS

1) RIGHT ANGLE NOSE ASSEMBLYS MAY REQUIRE MORE THAN ONE PULL.
2) ALUMINUM ONLY.
3) ALUMINUM & STEEL ONLY.
*ALL COUNTERSUNK 'C' NOSE ASSEMBLYS MAY BE USED TO INSTALL BOTH UNIVERSAL & COUNTERSUNK HEAD RIVETS

NOTE: THE LAST 2 DIGITS OF THE NOSE ASSEMBLY REPRESENTS THE LENGTH THE NOSE  
EXTENDS FROM THE TOOL I.E. -20 = 2.0 INCHES

5/18

### Grip Gage for CHERRYMAX® and CHERRYLOCK® fasteners # 269G3 (Sold Separately)

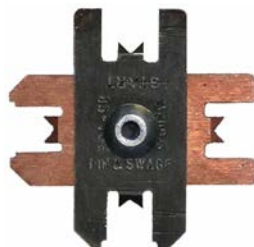

Gage Bilt also supplies pin & collar  
swage inspection gages to certify  
swage installation.  
(Sold Separately)





This page intentionally left blank

## Riveter Kits Available

(Sold Separately)



Contact Gage Bilt to customize your riveter kit today.



## Alternative Styles

(Sold Separately)

GB54B Pneumatic Riveter Includes stem collection bottle for FOD control

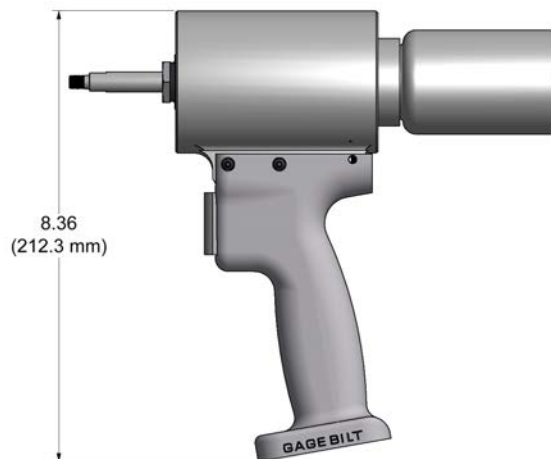

See GB54B nose assembly selection chart found on the GB54B flyer and manual at [www.gagebilt.com](http://www.gagebilt.com)

### **GB54B**

Stroke - .740" (18.8 mm)  
Hand held weight - 1.80 lbs. (0.82 kg)  
Entire tool weight - 1.80 lbs. (0.82 kg)  
Pull load - 700 lbs. (3.11 kN)