

# GB54B

## PNEUMATIC INSTALLATION TOOL



# GAGE BILT

RIVET & LOCKBOLT TOOLS



**INNOVATIVETOOLING**  
On the leading edge of Aircraft Tooling

800-832-7009

sales@innovativetooling.com

innovativetooling.com

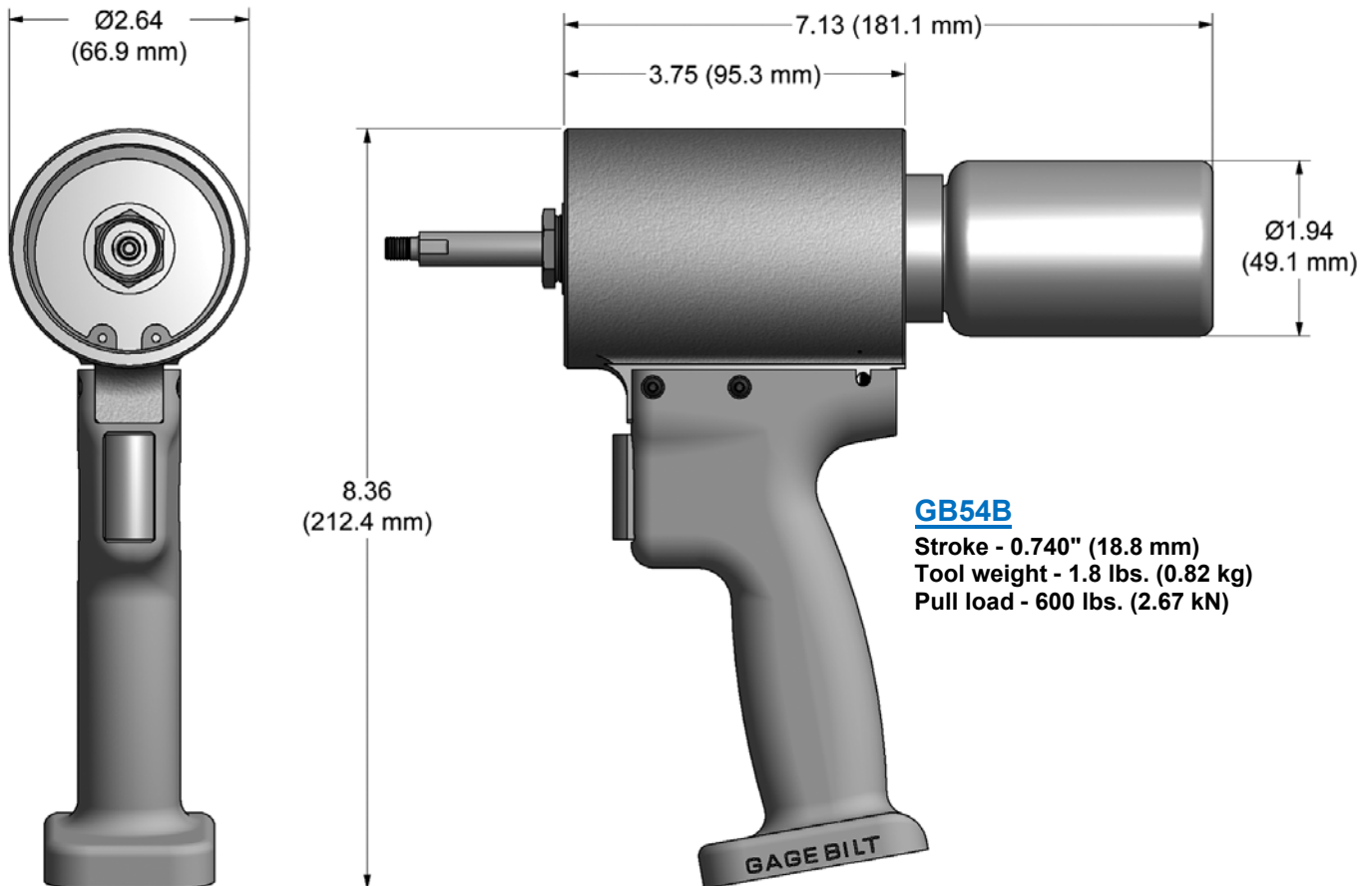

## DESCRIPTION

The **GB54B Pneumatic Riveter** is designed specifically for the most efficient installation of blind rivets. It will install aluminum rivets through 5/32" diameter and through 1/8" diameter rivets in any material. It weighs only 1.8 lbs. (0.82 kg) and can operate in any position.

The **GB54B Riveter** is 8.36" (212.3 mm) high, has a 0.740" (18.8 mm) stroke and generates a minimum of 600 lbs. (2.67kN) of pull at 90 psi (6.2 bar). It operates on 90-100 psi (6.2-6.9 bar) of air pressure at the tool. The **GB54B** does not exceed 81.5 dB(A) and consumes 0.29 SCF/cycle (8.21 L/cycle).

The air inlet is provided with 1/4-18 female pipe thread to accept the users air hose fitting.

**NOSE ASSEMBLIES ARE NOT FURNISHED WITH THIS TOOL AND MUST BE PURCHASED SEPARATELY**





**INNOVATIVE TOOLING**

On the leading edge of Aircraft Tooling

800-832-7009

sales@innovativetooling.com

innovativetooling.com

# GB54B



## NOSE ASSEMBLY SELECTION CHART

### ACCESSORIES

#### Grip Gage for CHERRYMAX® and CHERRYLOCK® rivets

# 269G3

(Sold Separately)

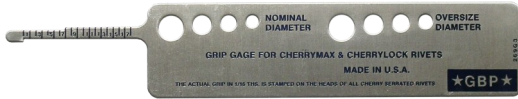

#### Grip Gage for NAS LOCKBOLTS and blind fasteners

#GB105093

((Sold Separately))



#### Riveter Kits Available

Contact Gage Bilt to create your own custom kit (Sold Separately)



#### Alternative Option

GB50 Pneumatic Riveter  
With stem catcher bag for FOD control



See GB50 nose assembly selection chart for GB50 nose assemblies (Sold Separately)

**STRAIGHT**  
(Sold Separately)



FASTENER	DIA.	STRAIGHT
NUT PLATE RIVETS MS20600 SERIES CCR244/264/274 MS/9SP/PT BACR15CC/CF/DA/DR	3/32   1/8	3C-54-43  4C-54-43
NAS1398A/1399A NAS1738A/1739A RV1000/1100 & 1200	3/32  1/8	3A-54-43 4A-54-43
<b>BLIND RIVET (SINGLE ACTION) WITH OR W/OUT DRIVE WASHER</b> NAS1900 S & U SERIES	1/8	SMLS04-54-43
OPEN END NAIL RIVET	3/32 1/8 <sup>1</sup>	3N-54-43 4N-54-43
CLOSED END NAIL RIVET (ALUMINUM MANDREL)	3/32 1/8	3N-54-43 4CEA-54-43
CLOSED END NAIL RIVET (STEEL MANDREL)	3/32 1/8	3N-54-43 4CES-54-43
FASTACK® AF5055 AF5055	3/32 1/8	3C-54-43 4C-54-43
SUPERTACK® AF5075 AF5076 S149A020	1/8  5/32	3A-54-43 4A-54-43

FASTACK® AND SUPERTACK® ARE REGISTERED TRADEMARKS OF ALLFAST FASTENING SYSTEMS INC.

#### GAGE BILT CERTIFIES THE GB54B WILL INSTALL THE ABOVE FASTENERS

1) ALUMINUM & STEEL ONLY.

\*ALL COUNTERSUNK 'C' NOSE ASSEMBLIES MAY BE USED TO INSTALL BOTH UNIVERSAL & COUNTERSUNK HEAD RIVETS

NOTE: THE LAST 2 DIGITS OF THE NOSE ASSEMBLY REPRESENTS THE LENGTH THE NOSE ASSY EXTENDS FROM THE TOOL I.E. -20 = 2.0 INCHES