

GB731

PNEUDRAULIC INSTALLATION TOOL

GAGE BILT

RIVET & LOCKBOLT TOOLS

INNOVATIVETOOLING
On the leading edge of Aircraft Tooling

800-832-7009

sales@innovativetooling.com

innovativetooling.com

GB731

Stroke - 0.600" (15.24 mm)
Hand held weight - 5.75 lbs. (2.61 kg)
Entire tool weight - 5.75 lbs. (2.61 kg)
Pull load - 4,800 lbs. (21.35 kN)

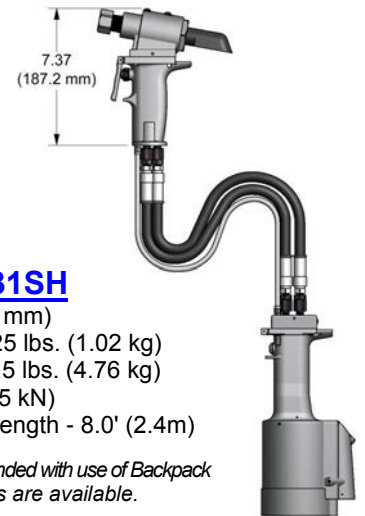
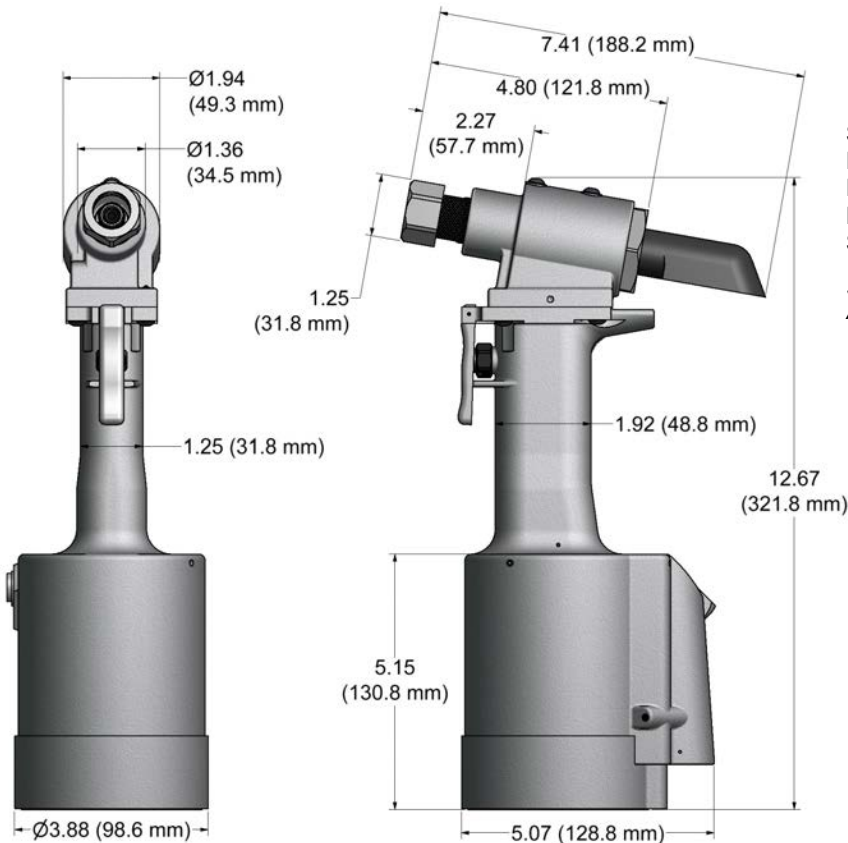

GB731SH

Stroke - 0.600" (15.24 mm)
Hand held weight - 2.25 lbs. (1.02 kg)
Entire tool weight - 10.5 lbs. (4.76 kg)
Pull load - 4,800 (21.35 kN)
Standard Hyd. Hose Length - 8.0' (2.4m)

*5ft Hyd. Hoses are recommended with use of Backpack
Additional custom lengths are available.*

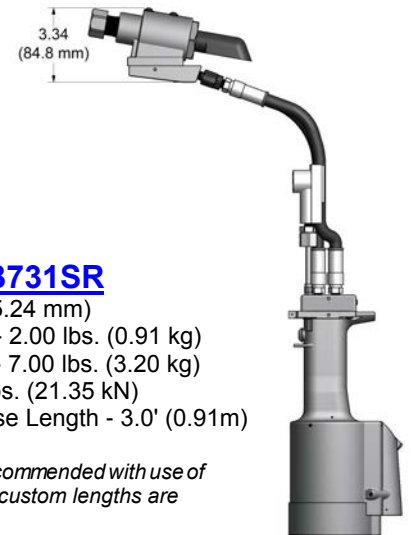

GB731SR

Stroke - 0.600" (15.24 mm)
Hand held weight - 2.00 lbs. (0.91 kg)
Entire tool weight - 7.00 lbs. (3.20 kg)
Pull load - 4,800 lbs. (21.35 kN)
Standard Hyd. Hose Length - 3.0' (0.91m)

*5ft Hyd. Hoses are recommended with use of Backpack
Additional custom lengths are available.*

The GB731 is a pneumatic-hydraulic installation tool designed specifically for the efficient installation of blind rivets and lockbolts. It weighs just under 5.75 lbs. (2.61 kg) and can be operated in any position. It has a 0.600" (15.24 mm) fastener setting stroke and a rated pull load of 4,800 lbs. (21.35 kN) on 90 psi (6.2 bar) air pressure at the air inlet.

The GB731 installation tool operates on 90 to 100 psi (6.2-6.9 bar) of air pressure, with 90 psi (6.2 bar) providing the maximum efficiency. At 90 psi. (6.2 bar) of air pressure, the GB731 does not exceed 81.5 dB(A) and consumes 0.16 SCF/cycle (4.53 L/cycle).

The GB731SH and GB731SR installation tools offer a unique "split" system providing the operator with an ergonomic tool with reduced hand held weight, as shown above. The GB731SH comes with 8 feet (2.4 m) of hose and the GB731SR comes with 3 feet (0.91 m) of hose.

The air inlet is provided with 1/4-18 female pipe thread for accepting the user's air hose fitting.

NOSE ASSEMBLIES ARE NOT FURNISHED WITH THIS RIVETER AND MUST BE ORDERED SEPARATELY.





ACCESSORIES

Catcher Bag-Stem #731610 (Sold Separately)



Grip Gage #269G3

For CHERRYMAX® and CHERRYLOCK® rivets
(Sold Separately)

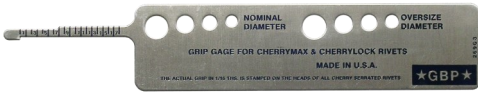

Grip Gage #GB105093

For NAS LOCKBOLTS and blind fasteners
(Sold Separately)



Stroke Limiter #731154

Required with selected right angle
nose assy's when used on GB731 tool.
See chart. (Sold Separately)



Adapter Assy #751204

Adapts GB204 series nose assemblies
to GB731 installation tool.
(Sold Separately)

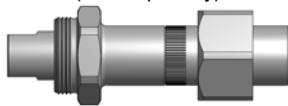

Gage Bilt also supplies
pin & collar swage
inspection gages
to certify swage
installation.
(Sold Separately)



Riveter Kits Available

Contact Customer
Service for more
information.
(Sold Separately)

GB731-NOSE ASSEMBLY SELECTION CHART

STRAIGHT
(Sold Separately)

RIGHT ANGLE
(Sold Separately)

OFFSET
(Sold Separately)



FASTENER	DIA.	STRAIGHT	*RIGHT ANGLE	**OFFSET	
'A' CODE NAS1398 & NAS1399 'A'	3/32 1/8 5/32 3/16 1/4	3A-352B-25 4A-752C-20 5A-752C-20 6A-752B-20 SMLS08-713-20	4A-752C-45 5A-752C-45 6A-752B-45 SMLS08-713-45	3A-751C-54RA 5 4A-751C-54RA 5 5A-751C-54RA 5 6A-751C-54RA 5	4A-752B-430S 5A-752B-430S 6A-752B-430S SMLS08-752B-430S
ASP® 2 ASP & ASP PF ASP FF & ASP F ASPLC & MAF	13/64 17/64	ASP06-752C-20 ASP08-752B-20	ASP06-752C-45 ASP08-752B-45	ASP06-751B-54RA 5 ASP08-751B-54RA 5	ASP06-752B-430S ASP08-752B-430S
LGP® LOCKBOLT LGPL2SC-V BACB30VM LGPL18SC-V BACB30XT LGPL4SC-V ABS0548 LGPL2SP-V BACB30VN LGPL4SP-V ASNA2392 LGPL8SC-V BACB30WD LGPL9SC-V BACB30WB LGPL9SP-V BACB30VY BACB31N BACB31P	5/32 3/16 7/32 1/4	LGP05-2480-10 LGP05-2480-45 LGP06-2480-10 LGP06-2480-45CF7 LGP06-2480-45 LGP07-731-10 LGP07-731-45 LGP08-2480-10 LGP08-2480-45 LGP08-2480-45CF8	LGP05-2480-20 LGP06-2480-20 LGP07-731-20 LGP08-2480-20	LGP06-204C-34OS LGP07-204C-25OS LGP07-204C-30OS LGP08-204C-25OS LGP08-204C-30OS	LGP05-204C-25OS LGP05-204C-30OS LGP06-204D-30OS LGP06-204D-30OS LGP07-204C-34OS LGP07-204C-30OS LGP08-204D-30OS LGP08-204D-30OS
MLGP® (MILLIMETER) LOCKBOLT	4 MM 5MM 6MM	MLGP4-730B-10 MLGP4-2480-45 MLGP5-730B-10 MLGP5-2480-45 MLGP6-730B-10 MLGP6-2480-45	MLGP4-2480-20 MLGP5-2480-20 MLGP6-2480-20	MLGP4-204C-25OS MLGP4-204C-34OS MLGP5-204C-25OS MLGP5-204C-34OS MLGP6-204C-25OS MLGP6-204C-34OS	MLGP4-204C-30OS MLGP5-204D-30OS MLGP6-204D-30OS
NAS and GP® SHEAR/TENSION LOCKBOLTS BACB30TY BACB30UA BACB30TZ BACB30UB BACB30DY BACB30GX BACB30DX BACB30GP BACB30GO BACB30GY BACB30GW	5/32 3/16 1/4	NASS05-2480-10 NASS05-2480-20 NASS05-2480-45 NAS06-730B-10 NAS06-2480-45 NAS08-352-10 NAS08-2480-45	NAST05-2480-10 NAST05-2480-20 NAST05-2480-45 NAS06-2480-20	NASS05-204C-25O NASS05-204C-30O NASS05-204C-34O NAS06-204C-25OS NAS06-204C-34OS NAS08-204C-25OS NAS08-204C-34OS	NAST05-204C-25O NAST05-204C-30O NAST05-204C-34O NAS06-204D-30OS NAS06-204D-30OS
MGP® (MILLIMETER) LOCKBOLT	4 MM 5 MM 6 MM	MGP4-730B-10 MGP4-2480-45 MGP5-730B-10 MGP5-2480-45 MGP6-730B-10 MGP6-2480-45	MGP4-2480-20 MGP5-2480-20 MGP6-2480-20	MGP4-204C-25OS MGP4-204C-34OS MGP5-204C-25OS MGP5-204C-34OS MGP6-204C-25OS MGP6-204C-34OS	MGP4-204C-30OS MGP5-204D-30OS MGP6-204D-30OS
CHERRYMAX® CHERRYMAX® 'AB' BACR15FR/FP BACR15GF/GK NAS1900 S & U SERIES BLIND RIVET WITH DRIVE WASHER	1/8 5/32 3/16 1/4	456MAX-X751-23 2 08MAX-752B-20	456MAX-751A-61 2 08MAX-752B-45	456MAX-751D-54RA 2 5 08MAX-713A-58RA 5	456MAX-X731-430S 2 08MAX-204D-27OS 08MAX-204D-37OS
BLIND BOLT (SINGLE ACTION) WITH OR W/OUT DRIVE WASHER MS90353S & U / MS90354S & U MS21140S & U / MS21141S & U MAXI-BOLT®, BACB30YY, YU, & YT	1/8 5/32 3/16 1/4	SMLS04-752C-20 SBS05-752C-20 SBS05-752C-80 SB06-752B-20 SB06-752B-80 SB08-713-20 6	SMLS04-752C-45 SBS05-752C-45 SB06-752B-45	SB05-751C-54RA 5 SB06-751B-54RA 5 SB08-713A-58RA 5	SB05-752A-43OS SB06-204D-27OS SB06-204D-37OS SB08-204D-27OS 6 SB08-204D-37OS 6
EN6122 & UAB130-EU EN6127 & UAB6127-EU EN6128 & UAB100-EU EN6129 & UABP-EU	5/32 3/16 1/4	UAB568-713-21 4 1/4	UAB568-713-61 4	UAB06-751B-54RA 5	UAB05-752B-43OS UAB06-752B-43OS UAB08-204D-27OS UAB08-204D-37OS
BLIND RIVET (SINGLE ACTION) WITH OR W/OUT DRIVE WASHER NAS1900 S & U SERIES	1/8 5/32 3/16 1/4	SMLS04-752C-20 SMLS05-752C-20 SMLS06-752B-20 SMLS08-713-20	SMLS04-752C-45 SMLS05-752C-45 SMLS06-752B-45 SMLS08-713-45	SMLS04-751C-54RA 5 SMLS05-751C-54RA 5 SMLS06-751C-54RA 5 SMLS08-713B-58RA	SMLS04-752B-430S SMLS05-752B-430S SMLS06-752B-430S SMLS08-752B-430S

ASP®, LGP®, MLGP®, MGP®, AND GP® ARE REGISTERED TRADEMARKS OF ARCONIC INC. CHERRYMAX®, MAXI-BOLT®, AND MBO® ARE REGISTERED TRADEMARKS OF CHERRY AEROSPACE FASTENERS.

GAGE BILT CERTIFIES THE GB731 WILL INSTALL THE ABOVE FASTENERS

- ** ALL OFFSET 204 SERIES NOSES REQUIRE 751204 ADAPTER.
- 1) RIGHT ANGLE NOSE ASSEMBLIES MAY REQUIRE MORE THAN ONE FULL.
- 2) INSTALLS 1/8, 5/32 & 3/16 DIAMETERS.
- 3) NOT FOR SHEAR AND TENSION IN ALLOY OR TITANIUM
- 4) INSTALLS 5/32, 3/16 & 1/4 DIAMETERS.
- 5) RIGHT ANGLE NOSE REQUIRES 731154 STROKE LIMITER.
- 6) 105 P.S.I. REQUIRED FOR MS90353 & MS90354
- 7) USED WITH THE GB5660S3SLCC (3SLC-C COLLAR) FEED AND SWAGE ACCESSORY. FOR ALL OTHER COLLARS CONTACT GAGE BILT FOR MORE INFORMATION.
- 8) USED WITH THE GB5680S3SLCC (3SLC-C COLLAR) FEED AND SWAGE ACCESSORY. FOR ALL OTHER COLLARS CONTACT GAGE BILT FOR MORE INFORMATION.

NOTE: THE LAST 2 DIGITS OF THE NOSE ASSEMBLY REPRESENTS THE LENGTH THE NOSE EXTENDS FROM THE TOOL. I.E. -20 = 2.0 INCHES

Feed N Swage
3/16" #GB5660S3SLCC
1/4" #GB5680S3SLCC
For LGP® 3SLC-C Collars
Contact Gage Bilt for more information.
(Sold Separately)

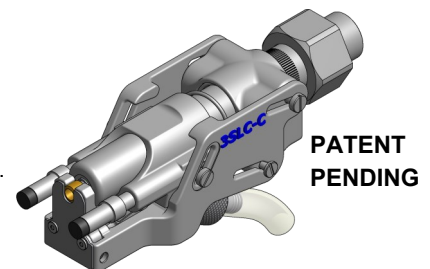

**PATENT
PENDING**