

GB731OS/206

INSTALLATION TOOL

GB731OS/206

Stroke - 0.500" (12.7 mm)
 Entire tool weight - 5.75 lbs. (2.6 kg)
 Pull load - 4,800 (21.4 kN)

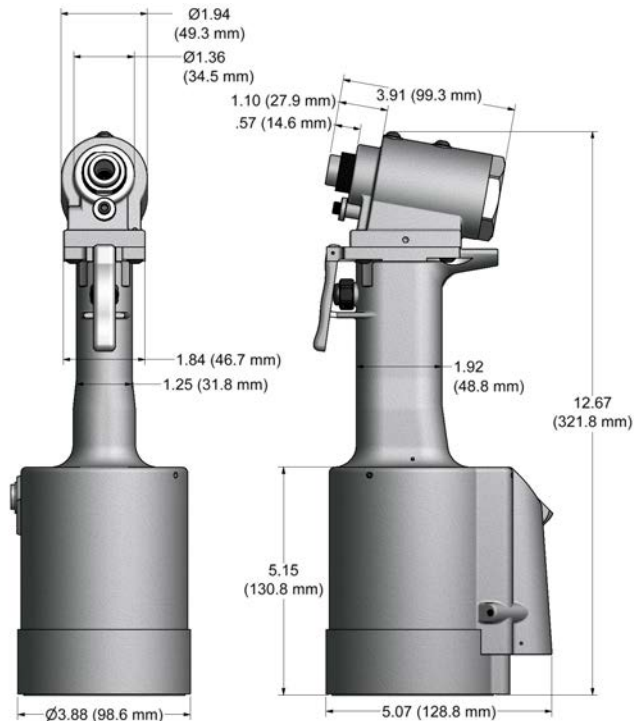

GB731OS/206SH

Stroke - 0.500" (12.7 mm)
 Hand held weight - 2.25 lbs. (1.02 kg)
 Entire tool weight - 10.5 lbs. (4.76 kg)
 Pull load - 4,800 (21.4 kN)

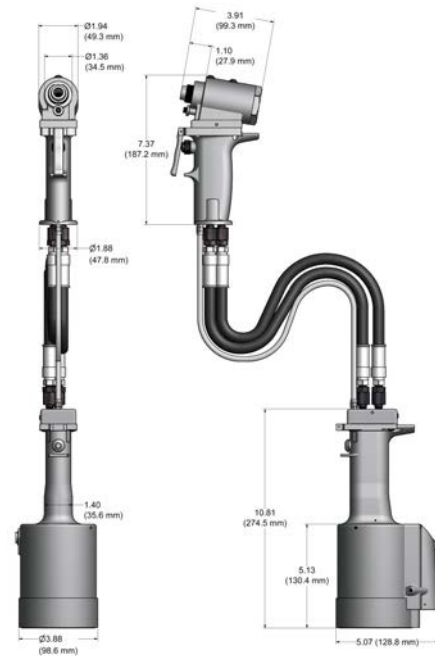

DESCRIPTION

The GB731OS/206 is a pneumatic-hydraulic installation tool designed specifically for the efficient installation of blind rivets and lockbolts and can be operated in any position. It has a 0.500" (12.7mm) rivet setting stroke and a rated pull load of 4,800 lbs. (21.4 kN) with 90 psi (6.2 bar) air pressure at the air inlet.

The GB731OS/206SH installation tool has a unique "split" system providing the operator with an ergonomic tool with reduced hand held weight.

The GB731OS/206 series operates on 90 to 100 psi (6.2-6.9 bar) of air pressure, with 90 psi (6.2 bar) providing the maximum efficiency. At 90 psi (6.2 bar) air pressure, the GB731OS/206 series does not exceed 81.5 dB(A) and consumes 0.16 SCF/cycle (4.53 L/cycle).

The air inlet is provided with 1/4-18 female pipe thread for accepting the user's air hose fitting.

Nose Assemblies that were designed for the Model 206-500 Installation tool mount directly on the GB731OS/206 without the use of an adapter.

NOSE ASSEMBLIES ARE NOT FURNISHED WITH THIS RIVETER AND MUST BE ORDERED SEPARATELY.

GAGE BILT
 **MADE in USA**

INNOVATIVETOOLING
 On the leading edge of Aircraft Tooling

800-832-7009

sales@innovativetooling.com

innovativetooling.com



Fill Bottle Assy
#745163
(Sold Separately)



AIR BLEEDER ASSY
#704153
(Equivalent to #700A77)
(Sold Separately)



SPLIT RIVETER TOOL BACKPACKS
For 5ft hose Split System Tools.
(Sold Separately)



Ergonomic Increases User Mobility	Reduces weight of tool by up to 70% Increases Productivity	Comfortable Reduces User Fatigue

Backpack fits any split riveter tool

Grip Gage #GB105093
(Equivalent to #105093)

For NAS LOCKBOLTS and blind fasteners
(Sold Separately)



RIVETER KITS

Gage Bilt offers a wide selection of standard and custom kits tailored to your needs. Contact us for more information.
(Sold Separately)



NOSE ASSEMBLY SELECTION CHART

STANDARD (Sold Separately) **STRADDLE NOSE** (Sold Separately) **LONG** (Sold Separately)

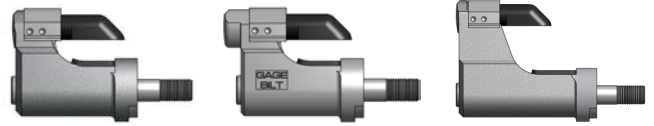

FASTENER	DIA.	STANDARD	STRADDLE NOSE (1)	LONG
LOCKBOLT, NAS SHEAR PULL TYPE, NAS TENSION PULL TYPE, NASS = SHEAR & GP® NAST = TENSION	5/32" 3/16" 1/4"	NAST05-206G-25OS NASS05-206G-25OS NAS06-206G-25OS NAS08-206G-25OS	NAST05-206G-30OS NASS05-206G-30OS NAS06-206H-30OS NAS08-206H-30OS	NAST05-206G-34OS NASS05-206G-34OS NAS06-206G-34OS NAS08-206G-34OS
MGP®	4mm 5mm	MGP4-206G-25OS MGP5-206G-25OS	MGP4-206G-30OS MGP5-206H-30OS	MGP4-206G-34OS MGP5-206G-34OS
LGP® Light weight Groove Proportion LOCKBOLT	5/32" 3/16" 7/32" 1/4"	LGP05-206G-25OS LGP06-206G-25OS LGP07-206G-25OS LGP08-206G-25OS	LGP05-206G-30OS LGP06-206H-30OS LGP07-206G-30OS LGP08-206G-30OS	LGP05-206G-34OS LGP06-206G-34OS LGP07-206G-34OS LGP08-206G-34OS
MLGP®	4mm 5mm	MLGP4-206G-25OS MLGP5-206G-25OS	MLGP4-206G-30OS MLGP5-206G-30OS	MLGP4-206G-34OS MLGP5-206G-34OS
BLIND RIVET (SINGLE ACTION) WITH OR W/OUT DRIVE WASHER NAS1900 S & U SERIES	1/8" 5/32" 3/16" 1/4"	SMLS04-206H-27OS SMLS05-206H-27OS SMLS06-206H-27OS SMLS08-206H-27OS		SMLS04-206H-37OS SMLS05-206H-37OS SMLS06-206H-37OS SMLS08-206H-37OS
BLIND BOLT (SINGLE ACTION) WITH OR W/OUT DRIVE WASHER MS90353S & U / MS90354S & U MS21140S & U / MS21141S & U MAXI-BOLT®, BACB30YY, YU, & YT	5/32" 3/16" 1/4"	SB05-206H-27OS SB06-206H-27OS SB08-206H-27OS		SB05-206H-37OS SB06-206H-37OS SB08-206H-37OS
EN6122 & UAB130-EU EN6127 & UAB6127-EU EN6128 & UAB100-EU EN6129 & UABP-EU	3/16" 1/4"	UBB06-206H-27OS UAB08-206G-27OS		UBB06-206H-37OS UAB08-206G-37OS
BACR15FR/FP, BACR15GF/GK, NAS1900 S & U SERIES BLIND RIVET WITH DRIVE WASHER NAS9301-9312	1/4"	08MAX-206G-27OS		08MAX-206G-37OS
"A" CODE NAS1398A & NAS1399A	1/8" 5/32" 3/16" 1/4"	4A-206G-27OS 5A-206G-27OS 6A-206G-27OS SMLS08-206H-27OS		4A-206G-37OS 5A-206G-37OS 6A-206G-37OS SMLS08-206H-37OS
ASP® ASP 2, ASP PF, ASP 4 FF, ASP 2 F, ASP 2 LC	13/64" 17/64" 21/64"	ASP06-206H-27OS ASP08-206H-27OS ASP10-206H-27OS		ASP06-206H-37OS ASP08-206H-37OS ASP10-206H-37OS
NAS1719, NAS1720, NAS1721 & MBC	1/8" 5/32" 3/16"	MBC04-206G-27OS MBC05-206G-27OS MBC06-206G-27OS		MBC04-206G-37OS MBC05-206G-37OS MBC06-206G-37OS
GROUND STUD, BACSS3B 2	13/64" 17/64"	GS8-206G-32OS GS10-206G-32OS		GS8-206G-42OS GS10-206G-42OS

GP®, MGP®, LGP®, MLGP®, AND ASP® ARE REGISTERED TRADEMARK OF ARCONIC INC. CHERRYMAX®, MAXI-BOLT®, AND MBC® ARE REGISTERED TRADEMARKS OF CHERRY AEROSPACE FASTENERS.

THE GB7310S/206 IS APPROVED TO INSTALL THE ABOVE FASTENERS.

- 1) -30 STRADDLE NOSES ARE DESIGNED TO REACH OVER THE COLLAR.
- 2) BACSS3B -10 ONLY

NOTE: TO REDUCE STROKE TO .375 UNLOADING VALVE (206110) AND STROKE LIMITER (206112) ARE AVAILABLE

NOTE: THE LAST 2 DIGITS OF THE NOSE ASSEMBLY REPRESENTS THE LENGTH THE NOSE ASSEMBLY EXTENDS FROM THE TOOL. (i.e. -25 = 2.5 inches)

6/17



Gage Bilt also supplies pin & collar swage inspection gages to certify swage installation.
(Sold Separately)

