

ORIGINAL INSTRUCTIONS

GB745/206-500SH

INSTALLATION TOOL

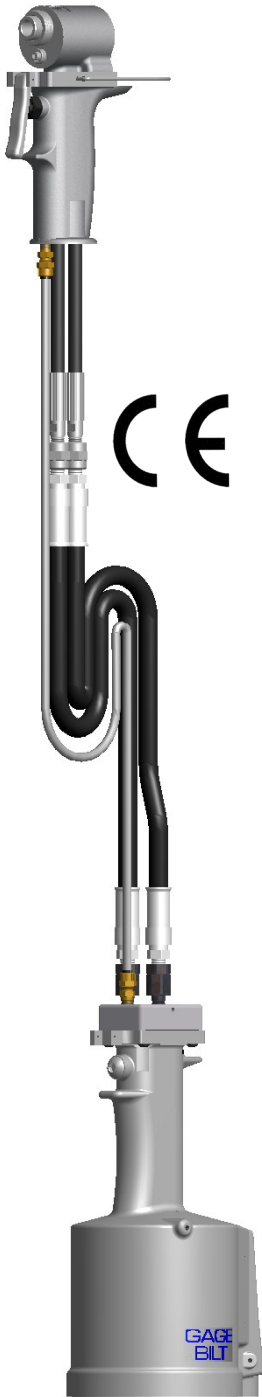

GAGE BILT
 **MADE in USA**



INNOVATIVETOOLING
On the leading edge of Aircraft Tooling

 800-832-7009

 sales@innovativetooling.com

 innovativetooling.com



	<u>Page</u>
EU Conformity and Warranty	3
Description and Technical Specifications	4
Description of Functions	5
Warnings.....	6
Principle of Operation	7
How to set-up the GB745/206-500SH.....	8
How to use the GB745/206-500SH	9
Maintenance and Hydraulic Thread Preparation	10
Filling and Bleeding	11-12
Troubleshooting	13
Overhaul	14-15
Parts Lists.....	16-17
DEXRON® III Oil Safety Data (SDS)	18
Nose Assembly Selection Chart	19
Accessories	20-24



GAGE BILT



DECLARATION OF CONFORMITY

MANUFACTURER: Gage Bilt Inc. 44766 Centre Ct. Clinton Twp. Michigan U.S.A. +1(586-226-1500)

WE DECLARE THAT THE EQUIPMENT SPECIFIED HEREIN CONFORMS TO THE FOLLOWING DIRECTIVES AND STANDARDS

Machinery Directive 2006/42/EC

EN12100-1 & EN12100-2

EN792-1:2000+A1

EU REPRESENTATIVE: Edgar Hausmann GmbH Förster-Busch-Str. 10 D-34346 Hann. Münden Germany

EQUIPMENT DESCRIPTION: GB745/206-500SH FASTENER INSTALLATION TOOL

This product specified above conforms to the above directives and standards.

SIGNATURE:

NAME: BRIAN LEIGH
PRODUCT MANAGER
CLINTON TWP., MI U.S.A.
APRIL 2019
+1(586) 226-1500

WARRANTY

Seller warrants that all goods covered by this catalog will conform to applicable specifications and will replace or repair, EXW our plant, any goods providing defective from faulty workmanship, or material, for 1 year from date of shipment.

Said warranty to remain in effect if and only if such goods are used in accordance with all instructions as to maintenance, operation and use, set forth in manuals and instruction sheets furnished by seller.

Seller obligation under this warranty shall be limited to the repair or rework of the goods supplied or replacement thereof, at Seller's option, and in no case is to exceed the invoice value of said goods. Under no circumstances will the seller be liable for incidental or consequential damages or for damages incurred by the buyer or subsequent user in repairing or replacing defective goods or if the goods covered by this warranty are reworked or subjected to any type of additional processing.

This warranty is void if Seller is not notified in writing of any rejections or defects within 1 year after the receipt of the material by the customer.

THIS WARRANTY IS MADE IN LEIU OF ALL OTHER WARRANTIES EXPRESSED OR IMPLIED, INCLUDING MERCHANTABILITY.

DESCRIPTION



⚠ WARNING: Any other use is forbidden.

The GB745/206-500SH Split Pneumatic-Hydraulic Installation Tool is designed specifically for the efficient installation of blind rivets and lockbolt fasteners. This tool's unique "split" system provides the operator with a lightweight ergonomic tool. It has a .500" (12.7mm) fastener setting stroke with a rated pull load of 5,600 lbs. (24.9 kN) at 90 psi. (6.2 bar) air pressure at the air inlet.

The GB745/206-500SH comes with 8 ft. (2.44 m) of hose. The GB745/206-500SH cylinder when held in your hand, weighs just 2.0 lbs (.91 kg)! While the entire split installation tool weighs 12 lbs (5.44 kg).

The GB745/206-500SH Split Pneumatic-Hydraulic Installation Tool operates on 90-100 psi. (6.2-6.9 bar) of air pressure, with 90 psi. (6.2 bar) providing maximum efficiency. At 90 psi. (6.2 bar) of air pressure the GB745/206-500SH does not exceed 81.5 dB(A) and consumes .30 SCF/cycle (8.50 L/cycle).

NOSE ASSEMBLIES ARE NOT FURNISHED WITH THE FASTENER AND MUST BE ORDERED SEPARATELY. (See nose assembly selection chart on pg. 19).

ENVIRONMENTAL USE

⚠ WARNING: Do not operate in an explosive atmosphere.

The GB745/206-500SH can be operated between 0°F — 118°F (-17.8°C / 47.8°C)

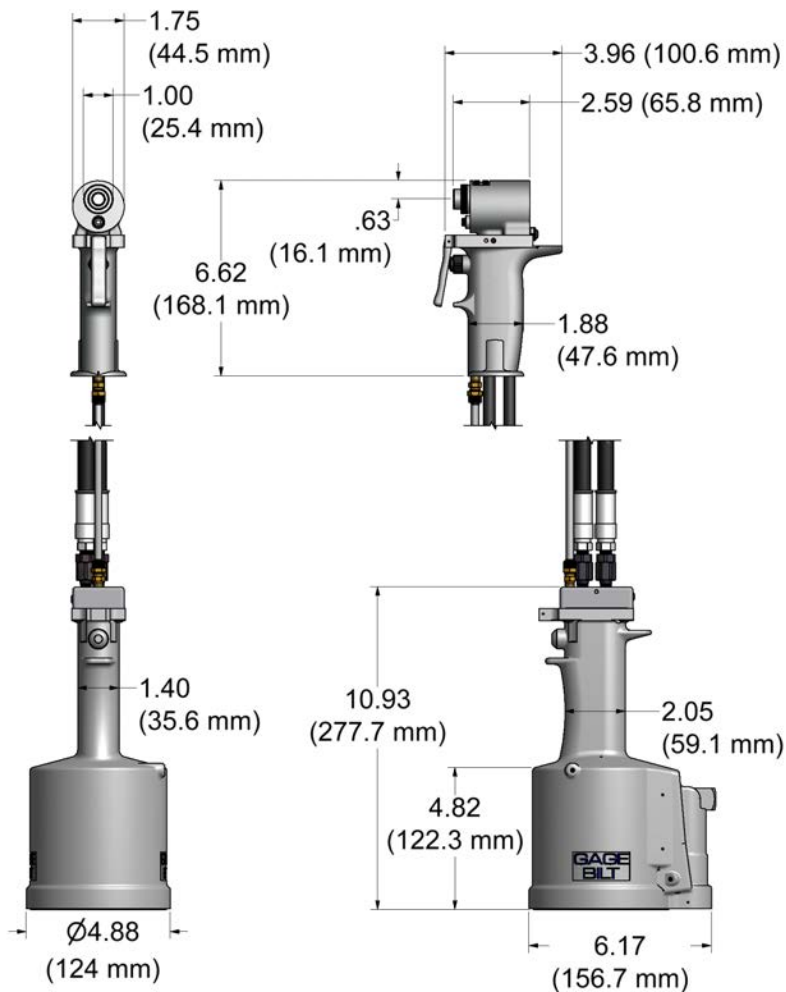

SPECIFICATIONS

Hand Held Weight	- 2.0 lbs. (0.91 kg)	
Weight	- 12 lbs. (5.44 kg)	
Air pressure req'd	- 90-100 p.s.i. (6.2-6.9 bar) Max.	
Air consumption	- 0.30 SCF/cycle (8.50 L/cycle).	
Hydraulic Oil	- Automatic Transmission Oil, Dexron® III, or equivalent.	
Setting stroke	- 0.500" (12.7mm)	
Rated pull load	- 5,600 lbs. (24.9 kN)	
Noise level		- Less than 81.5 dB(A)



DESCRIPTION OF FUNCTIONS



INNOVATIVE TOOLING

On the leading edge of Aircraft Tooling

800-832-7009

sales@innovativetooling.com

innovativetooling.com

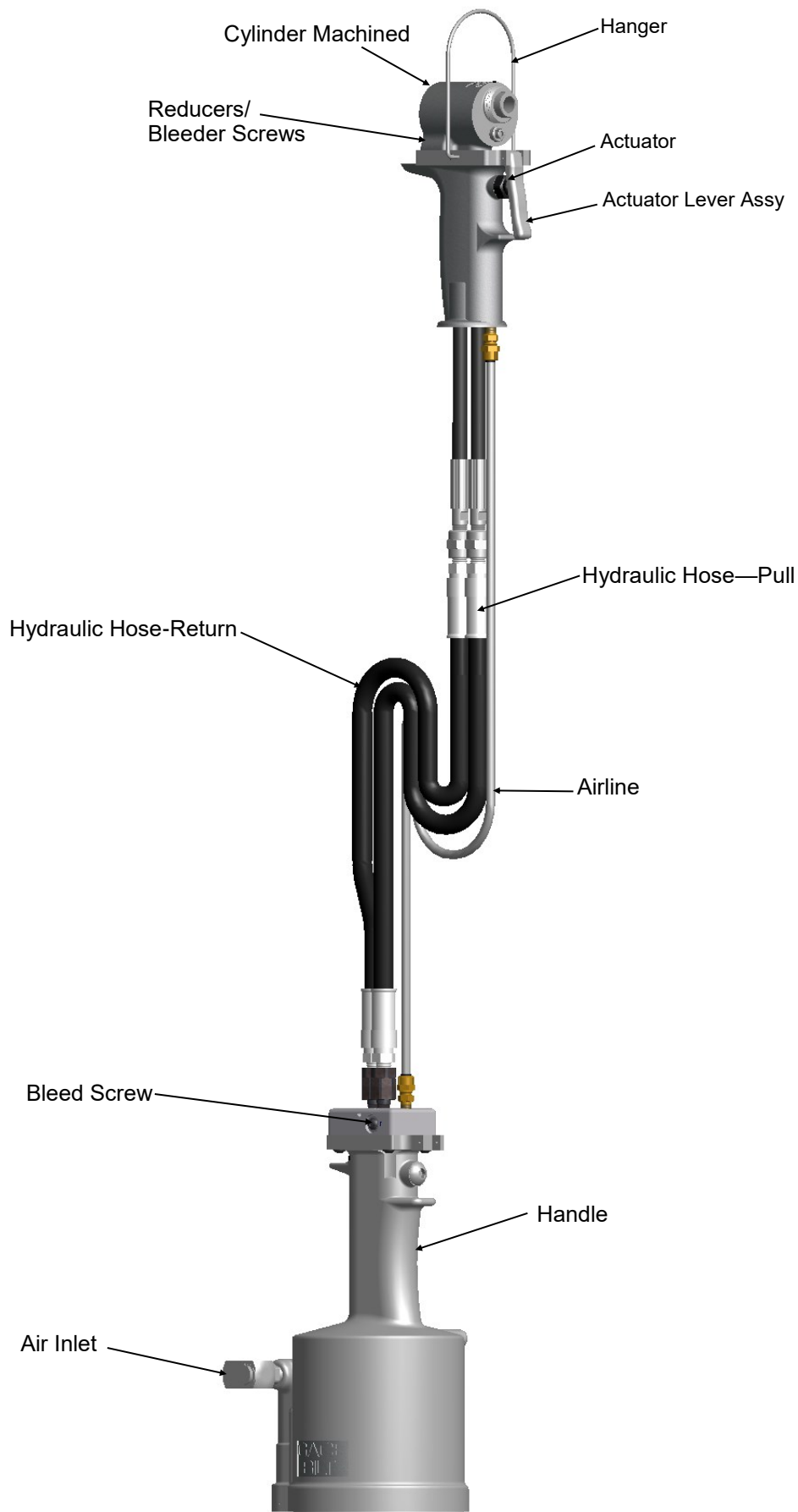

Image may not reflect actual tool



TERMS AND SYMBOLS



- Product complies with requirements



- Hearing protection and eye protection



- Read manual prior to using equipment



- Wear safety boots



WARNINGS - Must be understood to avoid severe personal injury.



CAUTIONS - show conditions that will damage equipment and/or structure.

Notes - are reminders of required procedures.

GENERAL SAFETY RULES:

1. For multiple hazards, read and understand the safety instructions before installing, operating, repairing, maintaining, changing accessories on, or working near the assembly power tool for non-threaded mechanical fasteners.
2. Only qualified and trained operators should install, adjust or use the assembly power tool for non threaded mechanical fasteners.
3. Do not modify this assembly power tool for non-threaded mechanical fasteners. Modifications can reduce effectiveness of safety measures and increase the risks to the operator.
4. Do not discard safety instructions; give them to the operator.
5. Do not use assembly power tool for non-threaded mechanical fasteners if it has been damaged.
6. Tools shall be inspected periodically to verify all ratings and markings required are legible. The employer/user shall contact the manufacturer to obtain replacement marking labels when necessary.
7. Air under pressure can cause severe injury.
8. Always shut off air supply, drain hose of air pressure and disconnect tool from air supply when not in use, before changing accessories or when making repairs.
9. Never direct air at yourself or anyone else.
10. Whipping hoses can cause severe injury. Always check for damage or loose hoses and fittings.
11. Cold air shall be directed away from hands.
12. Whenever universal twist couplings (claw couplings) are used, lock pins shall be installed and whipcheck safety cables shall be used to safeguard against possible hose-to-tool or hose-to-hose connection failure.
13. Do not exceed the maximum air pressure stated on the tool or manual.
14. Never carry an air tool by the hose.

ADDITIONAL SAFETY RULES FOR PNEUDRAULIC POWER TOOLS:

1. Air under pressure can cause severe injury.
2. Always shut off air supply, drain hose of air pressure and disconnect tool from air supply when not in use, before changing accessories or when making repairs.
3. Never direct air at yourself or anyone else.
4. Whipping hoses can cause severe injury. Always check for damage or loose hoses and fittings.
5. Cold air shall be directed away from hands.
6. Whenever universal twist couplings (claw couplings) are used, lock pins shall be installed and whipcheck safety cables shall be used to safeguard against possible hose-to-tool or hose-to-hose connection failure.
7. Do not exceed the maximum air pressure stated on the tool or manual.
8. Never carry an air tool by the hose.

PROJECTILE HAZARDS:

1. Disconnect the tool from the energy source when changing inserted tools/nose assemblies or accessories.
2. Be aware that failure of the workpiece or accessories, or even the inserted tool/nose assembly itself can generate high-velocity projectiles.
3. Always wear impact resistant eye protection during operation of the tool. The grade of protection required should be assessed for each use.
4. The risk to others should also be assessed at this time.
5. Ensure that the workpiece is securely fixed.
6. Check that the means of protection from ejection of fastener and/or stem is in place and operative (such as the deflector).
7. Forcible ejection of the mandrel from the front of the nose assembly is possible.

OPERATING HAZARDS:

1. Use of tool can expose the operator's hands to hazards, including crushing, impacts, cuts, abrasions and heat. Wear suitable gloves to protect hands.
2. Operators and maintenance personnel shall be physically able to handle the bulk, weight and power of the tool.
3. Hold the tool correctly; be ready to counteract normal or sudden movements and have both hands available.
4. Maintain a balanced body position and secure footing.
5. Release the start-and-stop device in the case of interruption of energy supply.
6. Use only lubricants recommended by the manufacturer.
7. Avoid unsuitable postures as it is likely for these positions not to allow counteracting of normal or unexpected movement of the tool.
8. If the tool is fixed to a suspension device, make sure that fixation is secure.
9. Beware of the risk of crushing or pinching if nose equipment is not fitted.
10. Due to the tool weight, it is recommended safety shoes be worn during operation.
11. It is recommended tool be operated not more than 50 out of every 60 minutes, where prolonged use is expected.

REPETITIVE MOTIONS HAZARDS:

1. When using the tool, the operator can experience discomfort in the hands, arms, shoulders, neck or other parts of the body.
2. While using the tool, the operator should adopt a comfortable posture while maintaining a secure footing and avoiding awkward or off balanced postures. The operator should change posture during extended tasks; this can help avoid discomfort and fatigue.
3. If the operator experiences symptoms such as persistent or recurring discomfort, pain, throbbing, aching, tingling, numbness, burning sensations or stiffness, these warning signs should not be ignored. The operator should tell the employer and consult a qualified health professional.

ACCESSORY HAZARDS:

1. Disconnect tool from energy supply before changing the nose assembly or accessory.
2. Use only sizes and types of accessories recommended by the manufacturer. Do not use other types or sizes of accessories.

WORKPLACE HAZARDS:

1. Slips, trips and falls are major causes of workplace injury. Be aware of slippery surfaces caused by use of tool and also of trip hazards caused by the air line or hydraulic hose.
2. Proceed with care in unfamiliar surroundings. There could be hidden hazards, such as electricity or other utility lines.
3. The tool is not intended for use in potentially explosive atmospheres and is not insulated against contact with electrical power.
4. Ensure that there are no electrical cables, gas pipes, etc., which can cause a hazard if damaged by the tool.

NOISE HAZARDS:

1. Exposure to high noise levels can cause permanent, disabling hearing loss and other problems, such as tinnitus (ringing, buzzing, whistling or humming in the ears). Therefore, risk assessment and the implementation of appropriate controls for these hazards are essential.
2. Appropriate controls to reduce the risk may include actions such as damping materials to prevent workpieces from "ringing".
3. Use hearing protection in accordance with employer's instructions and as required by occupational health and safety regulations.
4. Operate and maintain the assembly power tool for non-threaded mechanical fasteners as recommended in the instruction handbook, to prevent an unnecessary increase in the noise level.
5. Select, maintain and replace the consumable/inserted tool as recommended in the instruction handbook, to prevent an unnecessary increase in noise.
6. If the power tool has a silencer, always ensure that it is in place and in good working order when the power tool is being operated.

VIBRATION HAZARDS:

1. Exposure to vibration can cause disabling damage to the nerves and blood supply of the hands and arms.
2. Wear warm clothing when working in cold conditions and keep your hands warm and dry.
3. If you experience numbness, tingling, pain or whitening of the skin in your fingers or hands, stop using the assembly power tool for non-threaded mechanical fasteners, tell your employer and consult a physician.
4. Support the weight of the tool in a stand, tensioner or balancer, because a lighter grip can then be used to support the tool.



When the actuator is depressed, the throttle valve is shifted, directing the pressurized air inside the tool to the bottom of the air piston assy, moving it in an upward direction. The air above the air piston assy is then directed out the exhaust, on the bottom of the tool. Simultaneously, the piston rod assy connected to the air piston assy is also moving up, forcing hydraulic oil up and into the front of the cylinder machined, causing the piston assy to move to the rear of the cylinder machined. The oil from the rear of the cylinder machined is directed to the bottom of the piston rod assembly, inside the handle assy. The internal components of the attached nose assembly are also moving with the piston assy to start the fastener installation. When the fastener installation is completed the actuator is released allowing spring pressure to move the throttle valve to shift, directing the air pressure to the top side of the air piston assy and reversing the sequence.

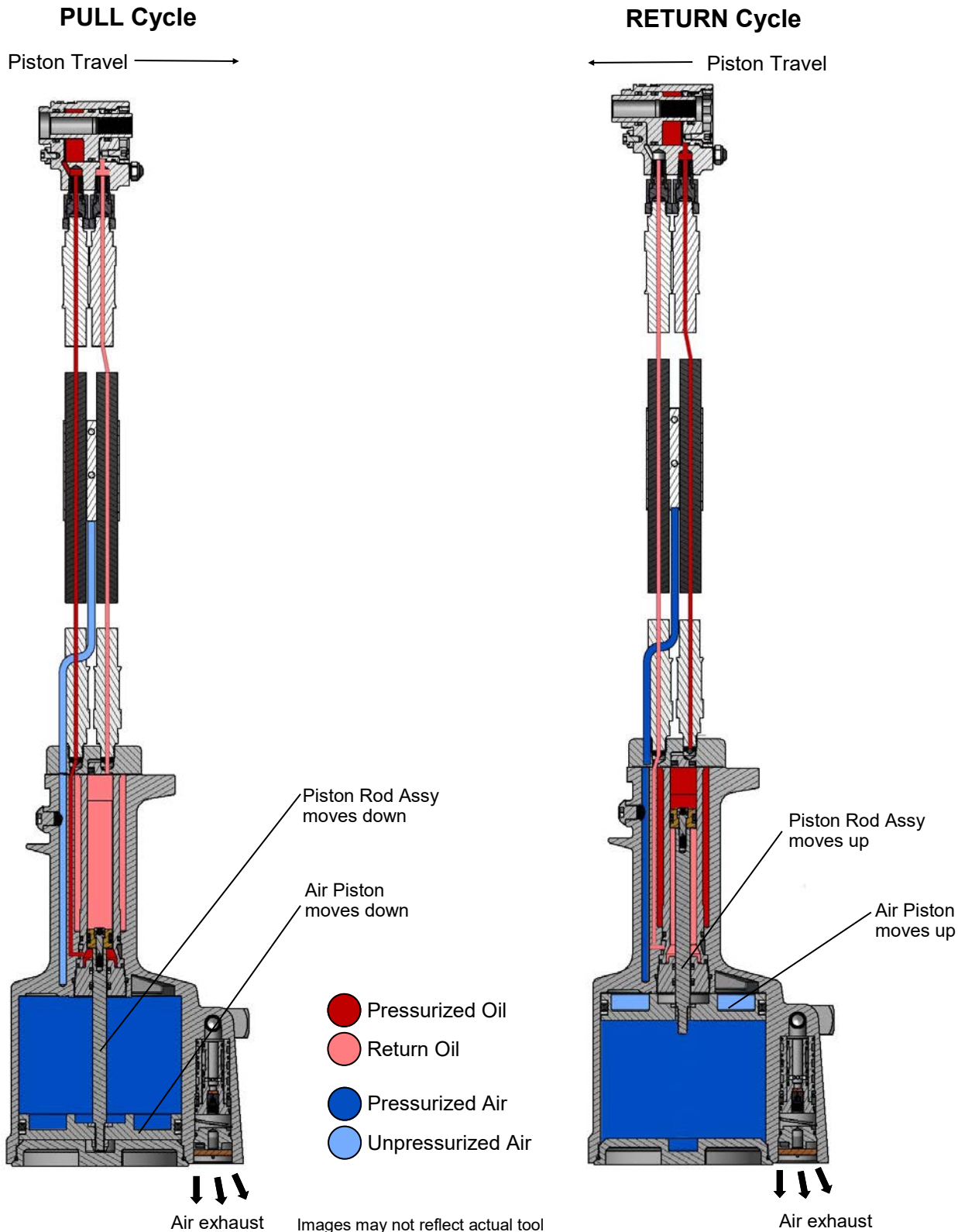

HOW TO SET-UP THE GB745/206-500SH



- ⚠ WARNING:** Only qualified and trained operators should install, adjust or use the assembly power tool for non-threaded mechanical fasteners.
- ⚠ WARNING:** Operator **MUST** read and understand all warnings and cautions.
- ⚠ WARNING:** It is required that eye protection, hearing protection and safety boots be worn at all times while handling this equipment.
- ⚠ WARNING:** The users or the user's employer should assess specific risks that could be present as a result after each use *based on their application*.
 - *Be sure there is adequate clearance for tool and operator's hands before proceeding. Keep fingers clear of any moving parts. Keep fingers clear from fasteners and installed materials. Severe personal injury may result.*
 - *Verify the air lines and/or hydraulic hoses are not a trip hazard.*
 - *Ensure that there are no electrical cables, gas pipes, etc., which can cause a hazard if damaged by the tool.*
- ⚠ WARNING:** Do not pull fastener in the air. Personal injury from fastener ejecting may occur.
- ⚠ WARNING:** Air is exhausted from the bottom of the tool. Direct bottom of the tool (exhausted air) away from operator, other persons working in the vicinity, foreign matter and liquid.
- ⚠ WARNING:** Do not carry from hoses or use as a hammer.
- ⚠ WARNING:** Do not use in explosive atmosphere.
- ⚠ WARNING:** Ensure air hose is securely connected to avoid possible hose whipping.
- ⚠ WARNING:** Always disconnect air supply when tool is not in use to prevent accidental start-up.
- ⚠ WARNING:** Be sure there is adequate clearance for tool and operator hands.
- ⚠ CAUTION:** Do not use beyond the design intent.

The tool is shipped with a red plastic plug in the air inlet connector. The connector has a 1/4-18 female pipe thread to accept user air hose fitting. The tool comes with oil and is ready to use.

1. Remove red plastic shipping plug from air inlet Swivel (A-249) and screw in your quick disconnect (air) fitting.
2. Connect tool to air hose with 90 psi. (6.2 bar) using clean, dry air. 3/8 minimum diameter air line is recommended. Cycle tool five times by depressing and releasing actuator assy-air (704130).
3. Disconnect air hose from tool.
4. Select proper nose assembly (See nose assy selection chart pg. 19 for more information). Screw drawbar into piston on tool and secure using hex key on front of drawbar. (See proper data sheet for further instructions.)
5. Connect air supply.

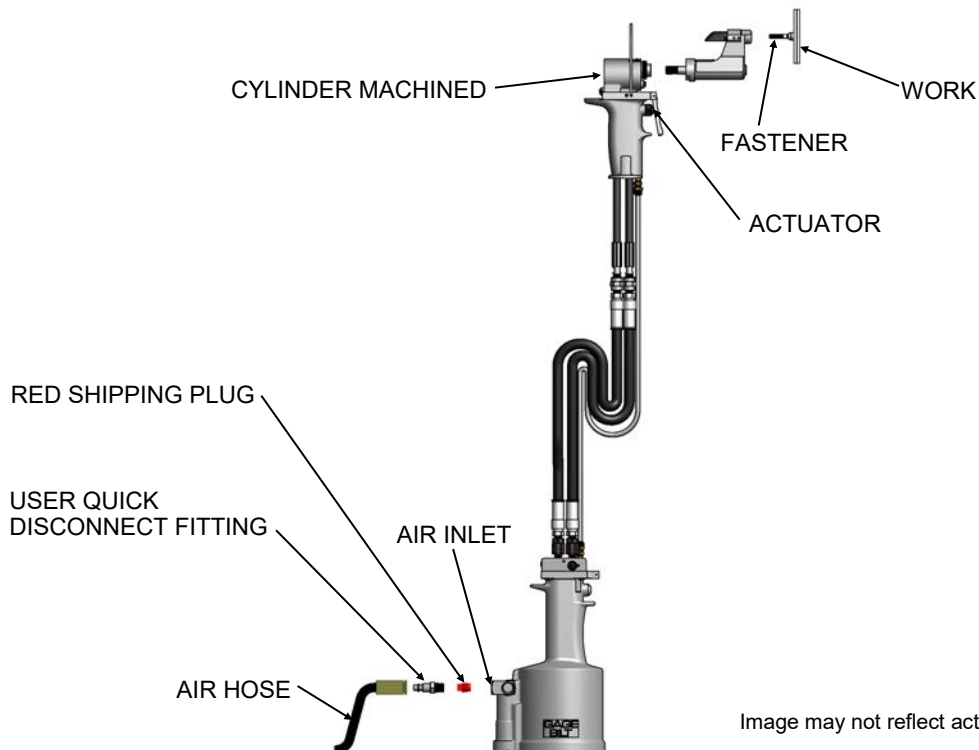

Image may not reflect actual tool



- ⚠ WARNING:** Only qualified and trained operators should install, adjust or use the assembly power tool for non-threaded mechanical fasteners.
- ⚠ WARNING:** Operator **MUST** read and understand all warnings and cautions.
- ⚠ WARNING:** It is required that eye protection, hearing protection and safety boots be worn at all times while handling this equipment.
- ⚠ WARNING:** The users or the user's employer should assess specific risks that could be present as a result after each use based on their application.
 - *Be sure there is adequate clearance for tool and operator's hands before proceeding. Keep fingers clear of any moving parts. Keep fingers clear from fasteners and installed materials. Severe personal injury may result.*
 - *Verify the air lines and/or hydraulic hoses are not a trip hazard.*
 - *Ensure that there are no electrical cables, gas pipes, etc., which can cause a hazard if damaged by the tool.*
- ⚠ WARNING:** Do not pull fastener in the air. Personal injury from fastener ejecting may occur.
- ⚠ WARNING:** Air is exhausted from the bottom of the tool. Direct bottom of the tool (exhausted air) away from operator, other persons working in the vicinity, foreign matter and liquid.
- ⚠ WARNING:** Do not carry from hoses or use as a hammer.
- ⚠ WARNING:** Do not use in explosive atmosphere.
- ⚠ WARNING:** Ensure air hose is securely connected to avoid possible hose whipping.
- ⚠ WARNING:** Always disconnect air supply when tool is not in use to prevent accidental start-up.
- ⚠ WARNING:** Be sure there is adequate clearance for tool and operator hands.
- ⚠ CAUTION:** Do not use beyond the design intent.

Lockbolts

#1. Insert fastener through the work piece.



#2. Slide collar over fastener.



#3. Insert tool onto fastener.



#4. Press actuator to start cycle.

#5. Release actuator as soon as fastener breaks.

#6. Repeat steps 1-5.

Blind Fasteners

1. Insert fastener.



2. Insert fastener into nose assembly.

Note: Always hold tool so pulling head is perpendicular to surface of material in which fastener is being installed. Exert firm pressure against fastener during installation



3. Press actuator to start cycle.



4. Release actuator as soon as fastener breaks.

5. Repeat steps 1-4.

Images may not reflect actual tool or fastener

DAILY MAINTENANCE



- ⚠ WARNING:** Tool must be maintained in a safe working condition at all times and examined on a daily basis for damage or wear. Any repair should be done by qualified personnel trained on Gage Bilt procedures.
- ⚠ WARNING:** Excessive contact with hydraulic oil and lubricants should be avoided.
- ⚠ WARNING:** Maintenance personnel **MUST** read and understand all warnings and cautions.
- ⚠ WARNING:** Disconnect tool from its power source before performing maintenance, cleaning or when replacing worn or damaged components. Severe personal injury may occur if power source is not disconnected.
- ⚠ WARNING:** Read SDS documents for all applicable materials.

The performance of any tool depends upon good maintenance practices. Following these minimal requirements for service and care will extend the life of your tool.

- *Only use a clean dry air supply set at 90-100 p.s.i. (6.2-6.9 bar) Max. equipped with a filter-regulator to prevent wear.
- *Proper care by operator is necessary in maintaining full productivity and reducing downtime. Read all applicable tool manuals and nose assembly data sheets prior to operating tools.
- *Check tool and nose assembly for damage. (Replace/Repair if necessary). See overhaul (pgs. 14-15) for tool repair.
- * Inspect hoses and couplings for wear, damage and leaks. (Replace/Repair if necessary). (See *hydraulic thread preparation below*).
- * Verify that hydraulic hose fittings and couplings, air and electrical connections are secure. Tighten, Replace or Repair if necessary (See *hydraulic thread preparation below*).
- *Keep nose assemblies, especially jaws, clean and free of chips and debris. Lube jaws and collet surfaces that jaws ride on with light machine oil on a daily basis.
- *All Screwed End Caps, Base Covers, Air Fittings, Air Actuators, Screws and Nose Assemblies are to be examined at the end of each working shift to check that they are secure.
- *Check tool, all hoses and all couplings daily for damage or air/hydraulic leaks. Tighten or replace (if necessary).
- *A complete overhaul can be achieved by the use of Service Kit (745214) which contains a complete set of o'rings, back-up rings, screws, washers and gasket.
- * For a complete overhaul, service tool kit (GB745/204TK-1) is recommended (see overhaul pg 14-15).

WEEKLY MAINTENANCE

- Keep the hydraulic system full (only use Dexron® III or equivalent) and free of air by using the air bleeder assy (704153) (sold separately) on a weekly basis. or as needed. (See Filling and Bleeding procedure pgs. 11-12).

SEE TROUBLESHOOTING (PG. 13) AND OVERHAUL (PGS. 14-15) FOR FURTHER GUIDANCE.

HYDRAULIC THREAD PREPARATION

IMPORTANT: Be sure to use thread sealant on all hydraulic fittings, Loctite® 545 or equivalent or a non-hardening Teflon® thread compound such as Slic-tite®. Tighten until fitting feels snug and then continue to tighten 1/2 to 1 full turn. **CAUTION:** Over tightening can easily distort the threads. **DO NOT USE TEFLON® TAPE.** **CAUTION:** Teflon® tape is an excellent thread sealer, however, if it is not properly applied, pieces of Teflon® may enter the hydraulic system and cause malfunction or damage.

TORQUE SPECIFICATIONS

Button Head Cap Screws (A-928) = 40 inch lbs.
Packing Plug (744118) = 45 foot lbs.
Flexlock Nut (400559) = 40 inch lbs.
Button Head Cap Screws (402482) = 35-40 inch lbs. (*Do NOT over-tighten*)

FILLING PROCEDURE



- ⚠ WARNING:** Do not cycle tool without air bleeder assy (704153) (sold separately), or the screw and stat-o-seal, installed in tool head. Severe personal injury could result.
- ⚠ CAUTION:** Before filling handle assy (744129), air piston assy (744121) should be all the way down.
- ⚠ CAUTION:** When forcing piston rod assy (745347) downward, with cylinder machined (204300-4) removed, hydraulic oil will eject forcibly from handle assy (744129).
- ⚠ CAUTION:** When bleeding tool, ensure tubing is free from kinks or other obstructions.
- ⚠ CAUTION:** Use CAUTION when removing screws, air bleeder assy (704153) and fill bottle (745263) (sold separately). Hydraulic oil may be under pressure.

Note:

- Air Bleeder Assy (704153) and fill bottle (745263) (sold separately) is required.

* FILLING & BLEEDING VIDEO AVAILABLE AT: http://www.gagebilt.com/rivet_tools_videos.php

IMPORTANT: Be sure to use thread sealant on all hydraulic fittings, Loctite® 545 or equivalent or a non-hardening Teflon® thread compound such as Slic-tite®. Tighten until fitting feels snug and then continue to tighten 1/2 to 1 full turn. **CAUTION:** Over tightening can easily distort the threads. DO NOT USE TEFLON® TAPE. **CAUTION:** Teflon® tape is an excellent thread sealer, however, if it is not properly applied, pieces of Teflon® may enter the hydraulic system and cause malfunction or damage.

To replace a small amount of oil in the tool, connect tool to air line, to ensure piston rod assy (745347) is at top of stroke. Follow steps 1-10 on pg. 12. Should it become necessary to completely refill the tool (such as would be required after tool has been dismantled and reassembled), follow all steps for both filling and bleeding procedures on both pages 11 & 12.

1. Ensure air piston assy (744121) is at the bottom of stroke by pushing piston rod assy (745347) down, piston assy (206129) should be at end of stroke.
2. Fill power cylinder (745345) and oil passage to the top, where o'ring (S832) sits.
3. Place gasket (745124) and o'ring (S832) on top of the handle assy (744129).
4. Install manifold-handle (745303-1), carefully install button head cap screws (A-928), tighten evenly. Torque to 40 inch lbs.
5. With hydraulic hoses (A-1668) attached to cylinder machined (204300-4), attach hydraulic hoses (A-1437) to female coupler (2X) (A-1624). Then attach hydraulic hoses (A-1437) to swivel assy (204304) (2X) on the manifold-handle (745303-1) and attach hydraulic Hoses (A-1668) to (A-1624) female coupler (2X).
6. Stretch tool out horizontally and lay flat on table or floor.
7. Attach fill bottle (745263) (sold separately), to bleeder hole marked "P" on manifold handle (745303-1).
8. Attach air bleeder assy (704153) (sold separately), to the pressure side, marked "P" on the rear of cylinder machined (204300-4).
9. Squeeze fill bottle (745263) (sold separately) on manifold-handle (745303-1) until no air rises into air bleeder assy (704153). Remove fill bottle (745263) (sold separately) & air bleeder assy (704153) (sold separately) and install button head cap screws (402482) and stat-o-seals (S572). (Do not over tighten). **CAUTION:** Do not cycle tool without button head cap screws (402482) or fill bottle (745263) (sold separately) & air bleeder assy (704153) (sold separately) installed in tool.
10. Repeat steps 7-9 using the return pressure holes (the bleeder hole marked "R" on manifold-handle (745303-1) and hole marked "R" on rear of cylinder machined (204300-4).

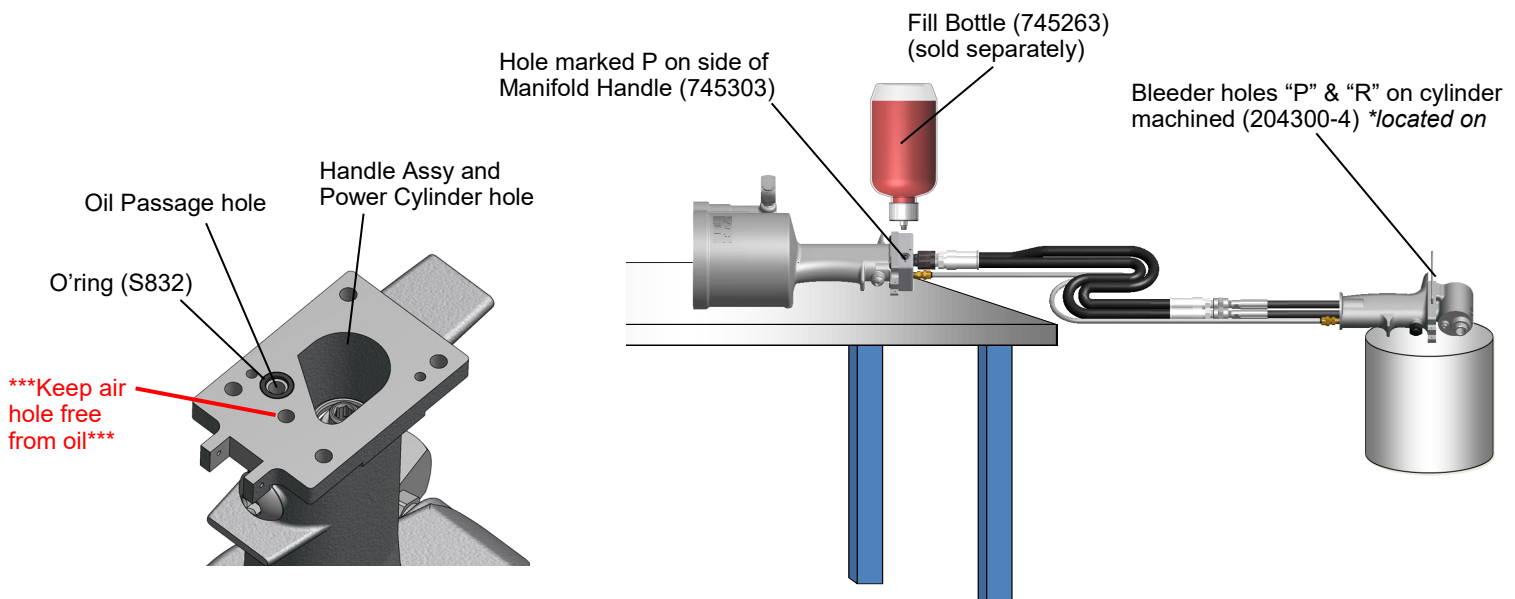

Images may not reflect actual tool

BLEEDING PROCEDURE



- ⚠ WARNING:** Do not cycle tool without air bleeder assy (704153) (sold separately), or the screw and stat-o-seal, installed in tool head. Severe personal injury could result.
- ⚠ CAUTION:** Before filling handle assy (744129), air piston assy (744121) should be all the way down.
- ⚠ CAUTION:** When forcing piston rod assy (745347) downward, with cylinder machined (204300-4) removed, hydraulic oil will eject forcibly from handle assy (744129).
- ⚠ CAUTION:** When bleeding tool, ensure tubing is free from kinks or other obstructions.
- ⚠ CAUTION:** Use CAUTION when removing screws, air bleeder assy (704153) and fill bottle (745263) (sold separately). Hydraulic oil may be under pressure.

Note:

- Air Bleeder Assy (704153) and fill bottle (745263) (sold separately) is required.

* FILLING & BLEEDING VIDEO AVAILABLE AT: http://www.gagebilt.com/rivet_tools_videos.php

IMPORTANT: Be sure to use thread sealant on all hydraulic fittings, Loctite® 545 or equivalent or a non-hardening Teflon® thread compound such as Slic-tite®. Tighten until fitting feels snug and then continue to tighten 1/2 to 1 full turn. **CAUTION:** Over tightening can easily distort the threads. DO NOT USE TEFLON® TAPE. **CAUTION:** Teflon® tape is an excellent thread sealer, however, if it is not properly applied, pieces of Teflon® may enter the hydraulic system and cause malfunction or damage.

To replace a small amount of oil in the tool, connect tool to air line, to ensure piston rod assy (745347) is at top of stroke. Follow steps 1-10 below. Should it become necessary to completely refill the tool (such as would be required after tool has been dismantled and reassembled), follow all steps for both filling and bleeding procedures on both pages 11 & 12.

1. Stand handle assy (744129) on floor, and stretch hydraulic hose assy (A-1437) upward on a table or bench laying cylinder machined (204300-4) flat on it's side.
2. Connect tool to air, slowly loosen button head cap screw (402482), marked "P" on the manifold-handle (745303-1). **CAUTION TOOL IS UNDER PRESSURE.** Let oil seep out. Remove button head cap screw (402482) and attach air bleeder assy (704153) (sold separately). Cycle ten times.
3. Remove air bleeder assy (704153) (sold separately) and install button head cap screw (402482) and stat-o-seal (S572) hole "P" on the manifold-handle (745303-1). (Do not over tighten).
4. With tool connected to air, slowly loosen button head cap screw (402482), marked "P" on back of cylinder machined **CAUTION TOOL IS UNDER PRESSURE.** Let oil seep out. Remove button head cap screw (402482), and attach air bleeder assy (704153) (sold separately). Cycle ten times.
5. Remove air bleeder assy (704153) (sold separately) and install button head cap screw (402482) and stat-o-seal (S572) to hole marked "P" on back of cylinder machined (204300-4). (Do not over tighten).
6. Hold actuator assy-air (704130) down until piston assy (206129) is at end of stroke, disconnect air.
7. Slowly loosen screw marked "R". (Back of cylinder machined). Remove screw and manually push piston assy (206129) to full rear position. **CAUTION:** Oil may bleed from oil port. Attach air bleeder assy (704153) (sold separately) connect tool to air and cycle tool ten times.
8. Hold actuator assy-air (704130) down until piston assy (206129) is at end of stroke. Disconnect air & remove air bleeder assy (704153) (sold separately) and install button head cap screw (402482) and stat-o-seal (S572) to hole "R" on rear of cylinder machined (204300-4). (Do not Over tighten).
9. Connect air and cycle tool several times.
10. Check stroke of .500" (12.7 mm) (see dim "A" & "B" below). We recommend using dial calipers. With the actuator assy-air (704130) released check dimension (A). Holding actuator assy-air (704130) in, check dimension (B). Add dimension (A) to dimension (B). If stroke is not consistent within 1/64" (.396 mm) repeat steps 2-10 until stroke met.

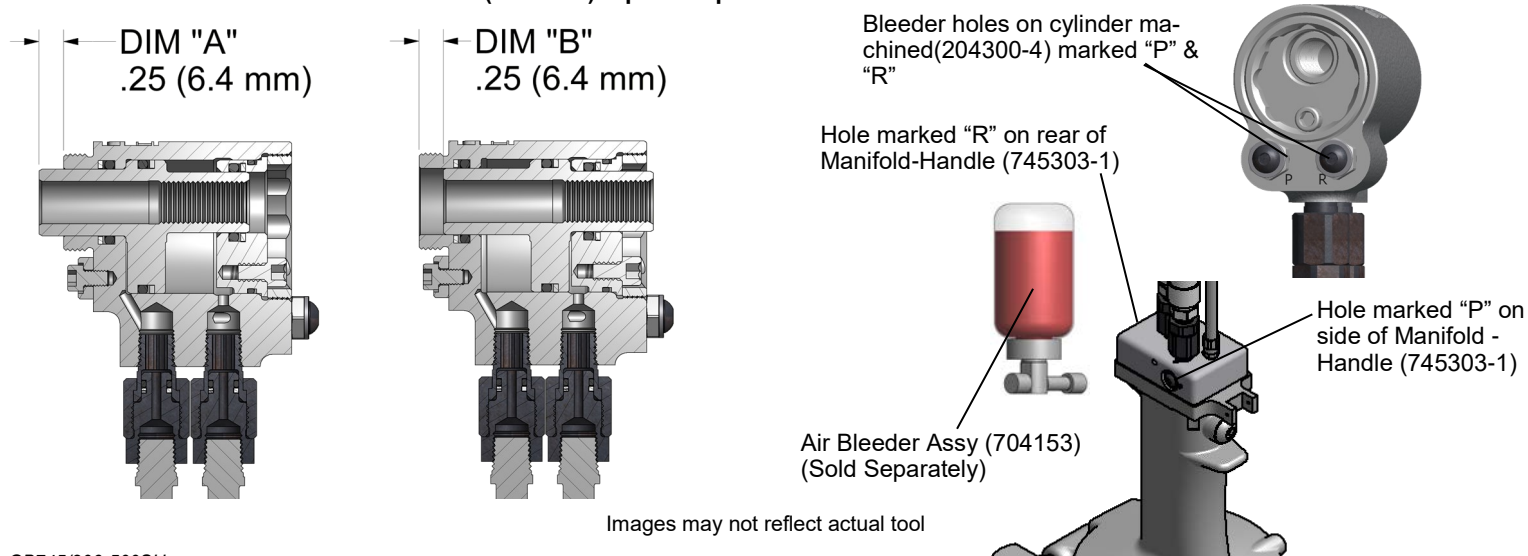

TROUBLESHOOTING



1. Check air line for correct pressure at the tool. It must be 90 to 100 psi. (6.2-6.9 bar) with 100 psi. (6.9 bar) Max.
2. Check tool for lack of hydraulic oil (see filling & bleeding procedures pgs. 11-12).
3. Check for oil leakage.
 - a. Hydraulic oil leaks from connections. Tighten threaded connections.
 - b. If oil should leak through the by-pass hole at the base of the handle assy (744129), quad rings (401462) is worn or damaged.
 - c. Oil leaking from the front of the cylinder machined (204300-4) indicates that o'ring (403802) is worn or damaged.
4. Check for excessive air leakage from air valve.
 - a. If spring (744144) is broken or dislodged, air will bleed directly through the bottom of the air valve and the piston assy (206129) will retreat to its full stroke without returning.
 - b. If o'ring (400785) on valve plug (744142) is worn or damaged, replace.
 - c. If o'rings (400779) on valve spool assy (743142) are worn or damaged, replace.
5. Check movement of piston assy (206129). If it does not move freely or is slow in operation:
 - a. O'ring (403810) may be damaged and require replacement.
 - b. Piston may be mechanically locked due to damaged parts.
 - c. Muffler (744143) or air filter inside valve spool assy (743142) may be blocked or damaged. Hole diameter should be .028" (.071 mm). Clear and size or replace valve spool assy (743142).
6. Fastener stem sticks in nose assembly.
 - a. Nose assembly components need maintenance. Disassemble nose assembly, clean and replace worn parts.
 - b. Spent pintail may be jammed in nose assembly. Disassemble nose assembly, remove pintails and reassemble.

OVERHAUL



- ⚠ WARNING:** Only qualified and trained personnel should perform overhaul.
- ⚠ WARNING:** Personnel must read and understand all warnings and cautions.
- ⚠ WARNING:** Tool must be maintained in a safe working condition at all times and examined on a daily basis for damage or wear. Any repair should be done by qualified personnel trained on Gage Bilt procedures.
- ⚠ WARNING:** Disconnect tool from its power source before performing overhaul. Severe personal injury may occur if power source is not disconnected.
- ⚠ WARNING:** Excessive contact with hydraulic oil and lubricants should be avoided (See SDS documents for all applicable materials).
- ⚠ WARNING:** When operating, repairing or overhauling tool, wear approved eye protection. Do not look in front of tool or rear of tool when installing fastener.
- ⚠ WARNING:** Use only Gage Bilt hydraulic hoses and couplings, or equivalent, rated for 10,000 psi. (689.5 bar) working pressure.
- ⚠ WARNING:** Ensure air hose is securely connected to avoid possible hose whipping (Air Actuated Tools only).
- ⚠ WARNING:** Depress actuator assy-air (704130) and disconnect from air, with the piston in the rear position, before overhaul. Severe personal injury may occur if air hose is not disconnected. **USE CAUTION** when forcing piston rod assy downward with cylinder machined removed. Hydraulic oil will eject forcibly from handle assy.

Note:

- Dispose of hydraulic oil in accordance with manufacture safety datasheet.
- All tool materials are recyclable except rubber o’rings, seals and wipers.

Perform overhaul in a clean, well lit area using care not to scratch or nick any smooth surface that comes in contact with an o’ring. Use of Lubriplate® (Gage Bilt part no. 402723) or other lubricant is recommended during reassembly to prevent tearing or distorting of o’rings.

The disassembly and re-assembly procedure can be accomplished by utilizing the following instructions and parts list on pg. 14-17. Use extreme care during disassembly and re-assembly not to mar or nick any smooth surface that comes in contact with seals. Before installing seals, always apply a good lubricant, such as Lubriplate, to the surfaces. It is recommended that service tool kit (GB745/204TK-1) be used to facilitate overhaul. A complete overhaul can be achieved by the use of Service Kit (745214) which contains a complete set of o’rings, back-up rings, screws, washers and gasket.

Clean parts in mineral spirits or other o’ring compatible solvent being sure to clean o’ring grooves. Inspect components for scoring, excessive wear or damage.

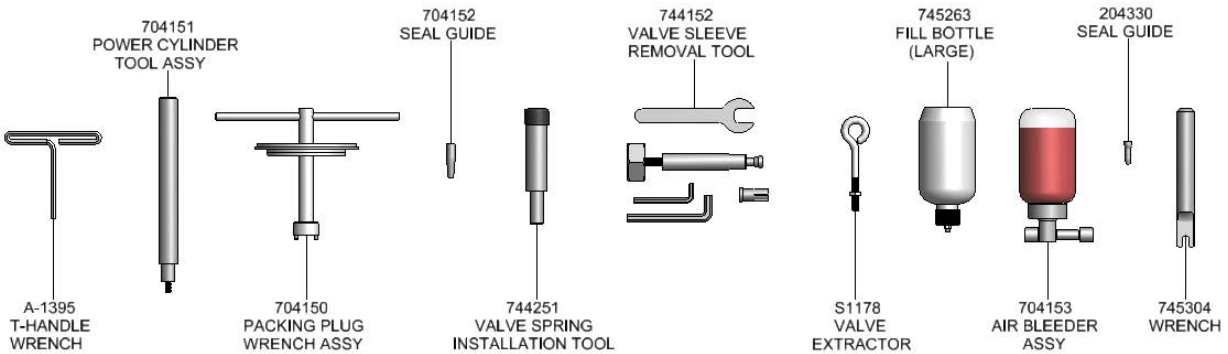

GB745/204TK-1 Service Tool Kit

Part No.	Description
A-1395	3" T-Handle Wrench
704151	Power Cylinder Tool Assy
704150	Packing Plug Wrench Assy
704152	Seal Guide
744251	Valve Spring Installation Tool
744152	Valve Sleeve Removal Tool
S1178	Valve Extractor
745263	Fill Bottle (Large)
704153	Air Bleeder Assy
204330	Seal Guide
745304	Wrench

TOOL DISPOSAL

1. When tool life is met, drain hydraulic oil from tool and dispose of the hydraulic oil in accordance with SDS datasheet.
2. Disassemble tool and remove all rubber o’rings, seals, wipers and hydraulic hoses. All tool materials are recyclable except rubber o’rings, seals, wipers and hydraulic hoses. Dispose of rubber materials in accordance with all environmental regulations applicable in your area.



⚠ WARNING: Disconnect tool from its air source before disassembly.

HEAD

Disconnect hydraulic hoses (A-1437) and tubing (703592) from manifold-handle (745303-1) and drain hoses. Push piston assy (206129) back to rear of the cylinder machined (204300-4) to empty all oil from the tool. Push piston assy (206129) to the front of the cylinder machined (204300-4).

Unscrew socket head cap screw (206118) from retaining ring (206117). Use a spanner wrench to remove retaining ring. Push piston assy (206129) back until cylinder machined cap assy (206115) falls out of cylinder machined (204300-4). Push piston assy (206129) out the rear of the cylinder machined (204300-4). Using a small blunt object, remove o-rings and back-up rings from components.

Clean parts mineral spirits or other o-ring compatible solvent being sure to clean o-ring grooves. Inspect components for scoring, excessive wear or damage.

Reassembly sequence is opposite of disassembly. Coat hose fitting threads with a non-hardening Teflon® thread compound such as Slic-tite® (GAGE BILT part no. 403237).

HANDLE

To inspect air cylinder bore, remove base cover (744124) . Any further disassembly will require removal of the manifold-handle (745303-1).

For complete disassembly.

1. Remove base cover (744124).
2. Holding tool upright, remove four button-head cap screws (A-928). Lift manifold-handle (745303-1) from handle assy (744129) and set aside o-ring (S832) and gasket (745124).
3. Empty all hydraulic oil into an approved container and dispose of in accordance with all environmental regulations applicable to your area.
4. Place T-Handle wrench (A-1395) down into top of power cylinder (745345) and into the hex of piston rod assy (745347). While holding the T-Handle wrench (A-1395), remove flexlock nut (400559) using a 7/16" socket wrench. Still holding T-Handle wrench (A-1395), remove air piston assy (744121) using power cylinder tool assy (704151).
5. When air piston assy (744121) is completely free from piston rod assy (745347), insert threaded end of power cylinder tool assy (704151) into bottom of air cylinder and remove air piston assy (744121).
6. After removal of air piston assy (744121), slide piston rod assy (745347) back up to the end of its travel. Using packing plug wrench assy (704150) remove packing plug (744118).
7. With packing plug (744118) removed, power cylinder (745345) can be removed by pushing on power cylinder tool assy (704151) when inserted into top of power cylinder (745345).

To reassemble the handle assy (744129).

1. Reverse the above procedure, being certain that all o-rings are properly lubricated before installation. Torque packing plug (744118) to 45 foot lbs.
2. Attach the seal guide (704152) to the piston rod assy (745347) and tap the piston rod assy (745347) through the packing plug (744118).
3. Attach air piston assy (744121) and flexlock nut (400559). Torque flexlock nut to 40 inch lbs.
4. Attach air piston assy (744121) to piston rod assy (745347).
5. With the piston rod in the down position, fill oil passage on top of handle assy (744129) with automatic transmission oil, Dexron® III or equivalent. When looking at top of handle assy (744129) the oil passage is the hole that has a counterbore for (S832) o-ring.
6. Replace gasket (745124) and o-ring (S832), just prior to re-attaching cylinder machined (204300-4). Torque all screws to manual specifications.
(See Filling & Bleeding procedures pgs. 11-12) & (See torque specs. pg. 10).

AIR VALVE

1. Remove pin (744149) and muffler (744143).
2. Insert valve extractor (S1178) into end of valve plug (744142) and pull it out.
3. Using the same procedure, pull out valve spool assy (743142).
4. It should never be necessary to remove valve sleeve (743144) unless the ports in the valve sleeve (743144) are plugged from contaminated air. If ports are plugged, use needle nose pliers to grasp end of spring (744144), turning clockwise and pulling to dislodge from groove in casting. Valve spring installation tool (744251) will facilitate the proper installation of the spring (744144).
5. Valve sleeve (743144) can be pulled out using valve sleeve removal tool (744152).



GB745/206-500 PARTS LIST



INNOVATIVETOOLING
On the leading edge of Aircraft Tooling

800-832-7009

sales@innovativetooling.com

innovativetooling.com

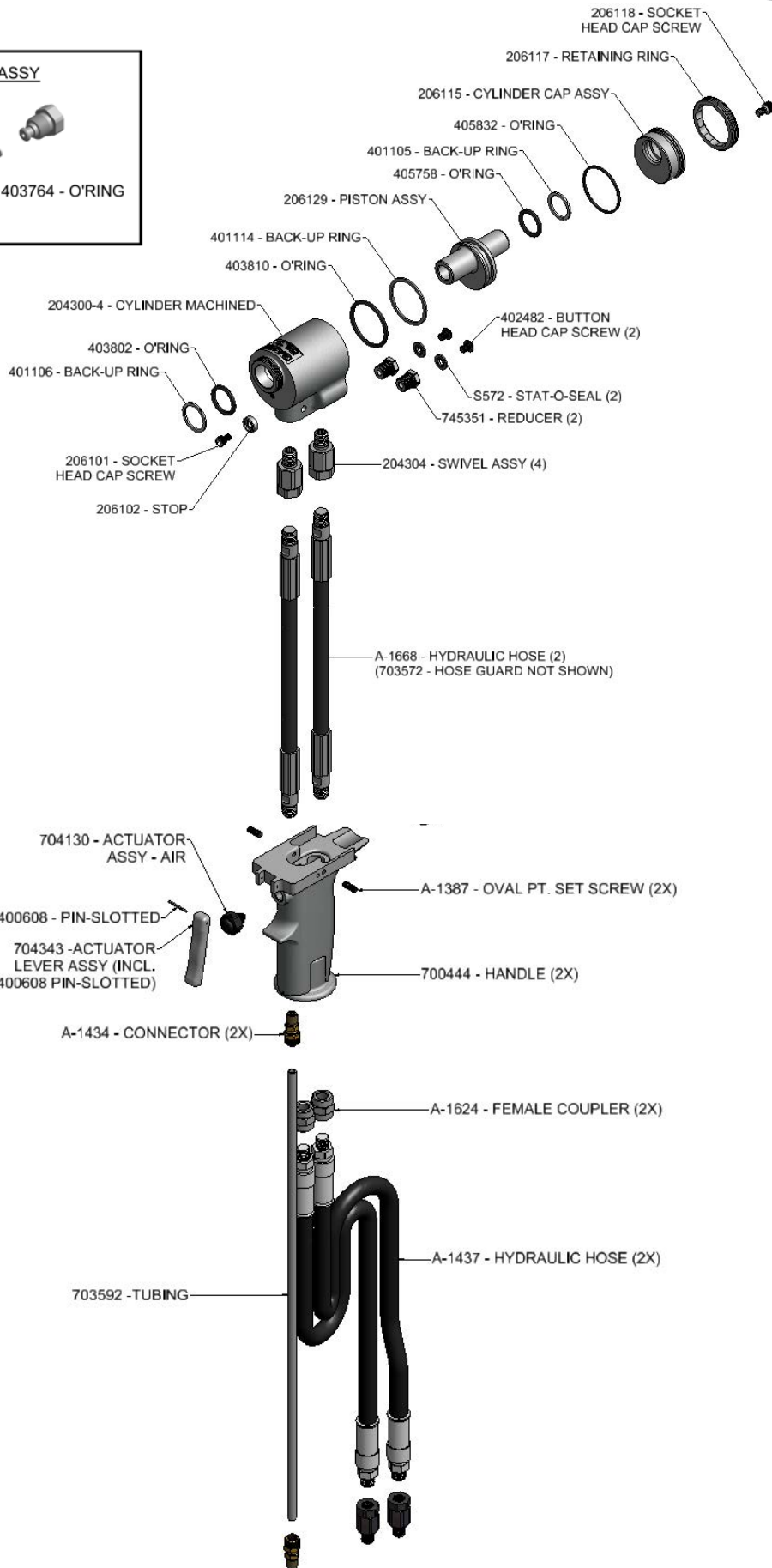
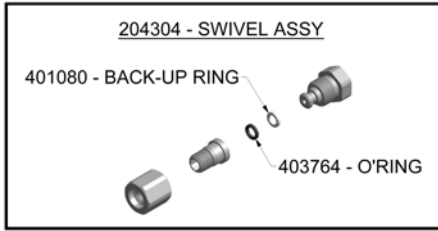



GB745/206-500 PARTS LIST



INNOVATIVE TOOLING

On the leading edge of Aircraft Tooling

800-832-7009

sales@innovativetooling.com

innovativetooling.com

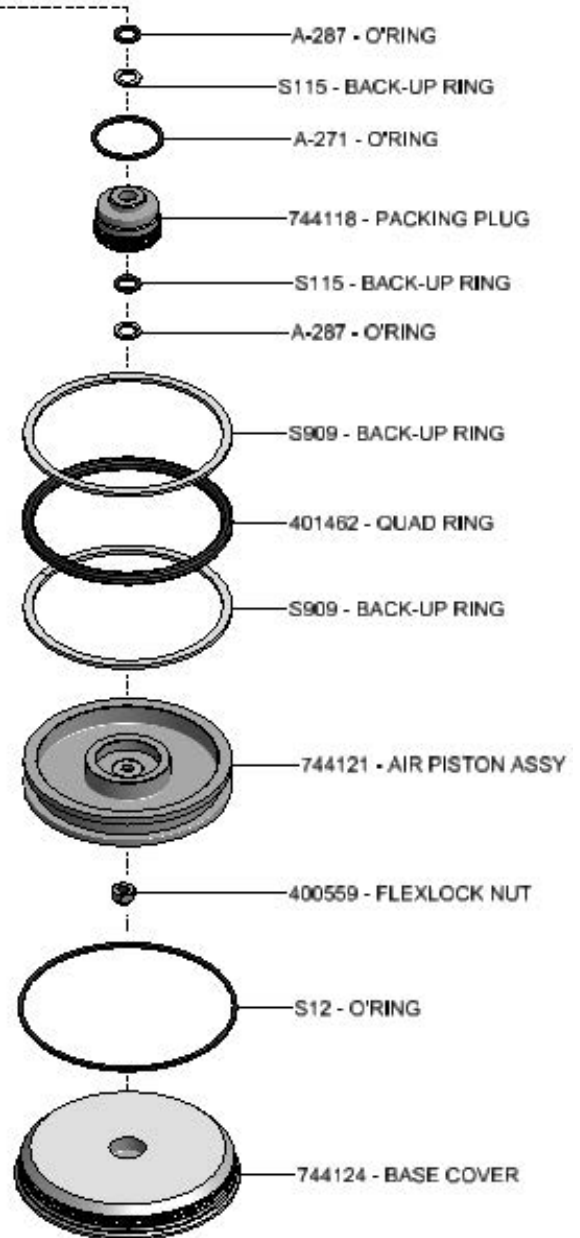
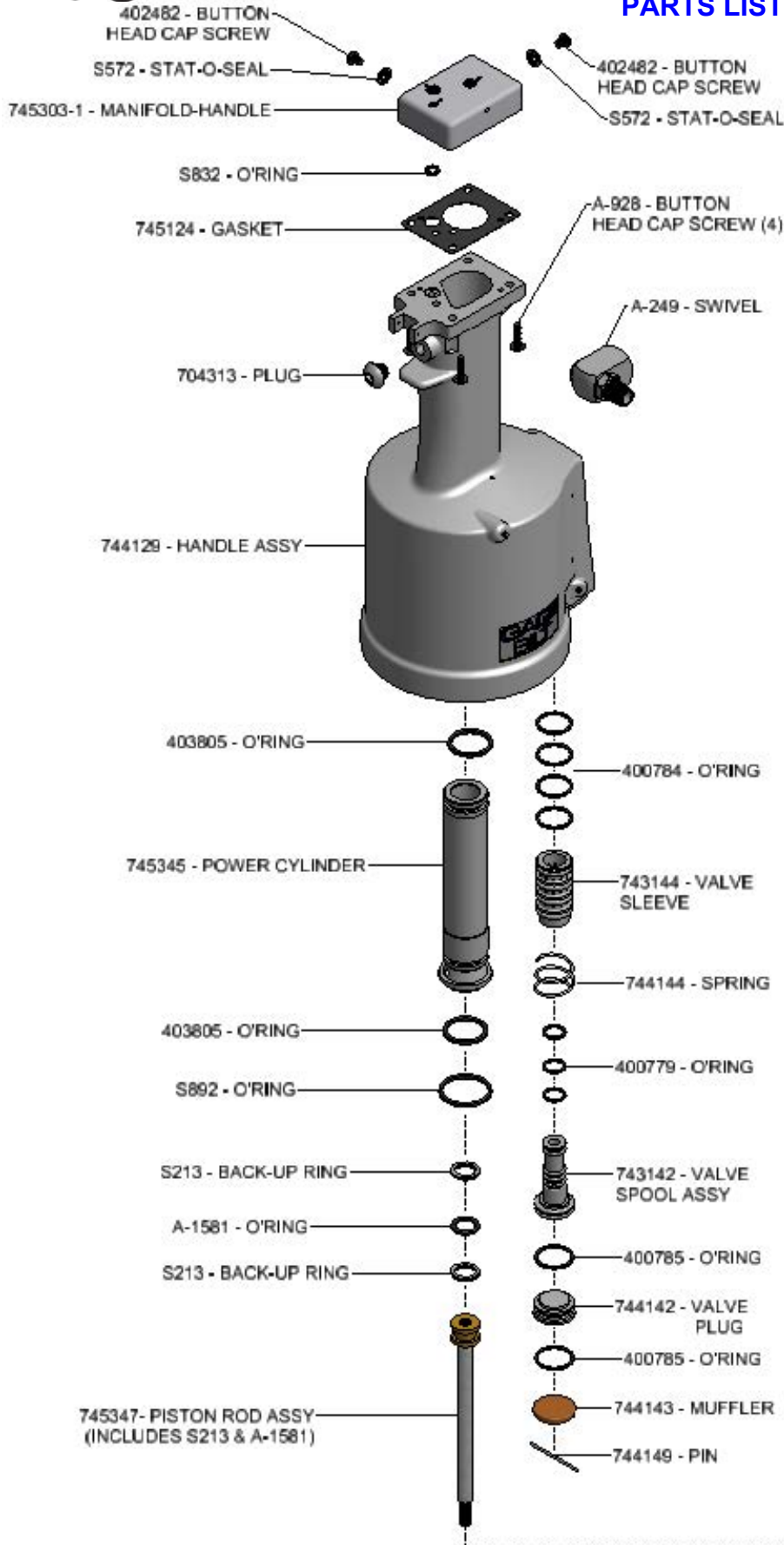

WARNING:

This tool incorporates a patented hydraulic relief valve. When overhauling tool, o-ring (A-1581) and back-up ring (S213) must be replaced. Failure to do so could result in SEVERE PERSONAL INJURY!

S213 - BACK-UP RING
A-1581 - O-RING
731139 - SCREW-PISTON ROD CAP
745347 - PISTON ROD ASSY
S213 - BACK-UP RING
400773 - O-RING

DEXRON® III OIL SAFETY DATA

FIRST AID MEASURES

Eye: No specific first aid measures are required. As a precaution, remove contact lenses, if worn, and flush eyes with water.

Skin: No specific first aid measures are required. As a precaution, remove clothing and shoes if contaminated. To remove the material from skin, use soap and water. Discard contaminated clothing and shoes or thoroughly clean before reuse.

Ingestion: No specific first aid measures are required. Do not induce vomiting. As a precaution, get medical advice.

Inhalation: No specific first aid measures are required. If exposed to excessive levels of material in the air, move the exposed person to fresh air. Get medical attention if coughing or respiratory discomfort occurs.

Note to Physicians: In an accident involving high-pressure equipment, this product may be injected under the skin. Such an accident may result in a small, sometimes bloodless, puncture wound. However, because of its driving force, material injected into a fingertip can be deposited into the palm of the hand. Within 24 hours, there is usually a great deal of swelling, discoloration, and intense throbbing pain. Immediate treatment at a surgical emergency center is recommended.

FIRE

Leaks/ruptures in high pressure system using materials of this type can create a fire hazard when in the vicinity of ignition sources (eg. open flame, pilot lights, sparks, or electric arcs).

FLAMMABLE PROPERTIES:

Flashpoint: (Cleveland Open Cup) 178 °C (352 °F) Minimum

EXTINGUISHING MEDIA: Use water fog, foam, dry chemical or carbon dioxide (CO₂) to extinguish flames.

PROTECTION OF FIRE FIGHTERS:

Fire Fighting Instructions: This material will burn although it is not easily ignited. See Section 7 for proper handling and storage. For fires involving this material, do not enter any enclosed or confined fire space without proper protective equipment, including self-contained breathing apparatus.

Combustion Products: Highly dependent on combustion conditions. A complex mixture of airborne solids, liquids, and gases including carbon monoxide, carbon dioxide, and unidentified organic compounds will be evolved when this material undergoes combustion.

ACCIDENTAL RELEASE MEASURES

Protective Measures: Eliminate all sources of ignition in vicinity of spilled material.

Spill Management: Stop the source of the release if you can do it without risk. Contain release to prevent further contamination of soil, surface water or groundwater. Clean up spill as soon as possible. Use appropriate techniques such as applying non-combustible absorbent materials or pumping. Where feasible and appropriate, remove contaminated soil. Place contaminated materials in disposable containers and dispose of in a manner consistent with applicable regulations.

ECOLOGICAL INFORMATION

Waste disposal: In accordance with all environmental regulations applicable to your area.

Spillage: Prevent entry into drains, sewers and water course. Soak up with diatomaceous earth or other inert material. Store in appropriate container for disposal.

Ecotoxicity: This material is expected to be harmful to aquatic organisms and may cause long-term adverse effects in the aquatic environment. The ecotoxicity hazard is based on an evaluation of data for the components or a similar material.

HANDLING

Precautionary Measures: DO NOT USE IN HIGH PRESSURE SYSTEMS in the vicinity of flames, sparks and hot surfaces. Use only in well ventilated areas. Keep container closed. Keep out of the reach of children.

General Handling Information: Avoid contaminating soil or releasing this material into sewage and drainage systems and bodies of water.

Static Hazard: Electrostatic charge may accumulate and create a hazardous condition when handling this material. To minimize this hazard, bonding and grounding may be necessary but may not, by themselves, be sufficient. Review all operations which have the potential of generating and accumulating an electrostatic charge and/or a flammable atmosphere (including tank and container filling, splash filling, tank cleaning, sampling, gauging, switch loading, filtering, mixing, agitation, and vacuum truck operations) and use appropriate mitigating procedures.

DISPOSAL CONSIDERATIONS

Use material for its intended purpose or recycle if possible. Oil collection services are available for used oil recycling or disposal. Place contaminated materials in containers and dispose of in a manner consistent with applicable regulations.



GB745/206-500 - NOSE ASSEMBLY SELECTION CHART



FASTENER	DIA.	STANDARD	STRADDLE NOSE (1)	LONG
LOCKBOLT, NAS SHEAR PULL TYPE, NAS TENSION PULL TYPE, NASS=SHEAR & GP® NAST=TENSION	5/32" 3/16" 1/4"	NAST05-206G-25OS NASS05-206G-25OS NAS06-206G-25OS NAS08-206G-25OS	NAST05-206G-30OS NASS05-206G-30OS NAS06-206H-30OS NAS08-206G-30OS	NAST05-206G-34OS NASS05-206G-34OS NAS06-206G-34OS NAS08-206G-34OS
MGP®	4mm 5mm 6mm	MGP4-206G-25OS MGP5-206G-25OS MGP6-206G-25OS	MGP4-206G-30OS MGP5-206H-30OS MGP6-206H-30OS	MGP4-206G-34OS MGP5-206G-34OS MGP6-206G-34OS
LGP® Light weight Groove Proportion LOCKBOLT	5/32" 3/16" 7/32" 1/4"	LGP05-206G-25OS LGP06-206G-25OS LGP07-206G-25OS LGP08-206G-25OS	LGP05-206G-30OS LGP06-206H-30OS LGP07-206G-30OS LGP08-206G-30OS	LGP05-206G-34OS LGP06-206G-34OS LGP07-206G-34OS LGP08-206G-34OS
MLGP®	4mm 5mm 6mm	MLGP4-206G-25OS MLGP5-206G-25OS MLGP6-206G-25OS	MLGP4-206G-30OS MLGP5-206G-30OS MLGP6-206G-30OS	MLGP4-206G-34OS MGLP5-206G-34OS MGLP6-206G-34OS
BLIND RIVET (SINGLE ACTION) WITH OR W/O DRIVE WASHER NAS1900 S & U SERIES	1/8" 5/32" 3/16" 1/4"	SMLS04-206H-27OS SMLS05-206H-27OS SMLS06-206H-27OS SMLS08-206H-27OS		SMLS04-206H-37OS SMLS05-206H-37OS SMLS06-206H-37OS SMLS08-206H-37OS
BLIND BOLT (SINGLE ACTION) WITH OR W/O DRIVE WASHER MS90353S & U / MS90354S & U MS21140S & U / MS21141S & U MAXI-BOLT®, BACB30YY, YU, & YT	5/32" 3/16" 1/4"	SB05-206H-27OS SB06-206H-27OS SB08-206H-27OS		SB05-206H-37OS SB06-206H-37OS SB08-206H-37OS
EN6122 & UAB130-EU EN6127 & UAB6127-EU EN6128 & UAB100-EU EN6129 & UABP-EU	3/16" 1/4"	UAB06-206H-27OS UAB08-206H-27OS		UAB06-206H-37OS UAB08-206H-37OS
BACR15FR/FP, BACR15GF/GK, NAS1900 S & U SERIES BLIND RIVET WITH DRIVE WASHER NAS9301-9312	1/4"	08MAX-206H-27OS		08MAX-206H-37OS
"A" CODE NAS1398A & NAS1399A	1/8" 5/32" 3/16" 1/4"	4A-206H-27OS 5A-206H-27OS 6A-206H-27OS SMLS08-206H-27OS		4A-206H-37OS 5A-206H-37OS 6A-206H-37OS SMLS08-206H-37OS
ASP® ASP2, ASP PF, ASP 4 FF, ASP 2 F, ASP 2 LC	13/64" 17/64" 21/64"	ASP06-206H-27OS ASP08-206H-27OS ASP10-206H-27OS		ASP06-206H-37OS ASP08-206H-37OS ASP10-206H-37OS
NAS1719, NAS1720, NAS1721	1/8" 5/32" 3/16"	MBC04-206H-27OS MBC05-206H-27OS MBC06-206H-27OS		MBC04-206H-37OS MBC05-206H-37OS MBC06-206H-37OS
GROUND STUD, BACS53B 2	13/64" 17/64"	GS8-206H-32OS GS10-206H-32OS		GS8-206H-42OS GS10-206H-42OS

GP®, MGP®, LGP®, MLGP®, AND ASP® ARE REGISTERED TRADEMARKS OF ARCONIC INC. MAXI-BOLT®, IS A REGISTERED TRADEMARK OF CHERRY AEROSPACE FASTENERS.

GAGE BILT CERTIFIES THE GB745/206-500 WILL INSTALL THE ABOVE FASTENERS

- 1) -30 STRADDLE NOSES ARE DESIGNED TO REACH OVER THE COLLAR.
- 2) BACS53B -10 ONLY

NOTE: THE LAST 2 DIGITS OF THE NOSE ASSEMBLY REPRESENTS THE LENGTH THE NOSE
EXTENDS FROM THE TOOL I.E. -25 = 2.5 inches

Rev. 4/18

Accessories

(Sold Separately)



Adapter Assy

#206751

Adapts GAGE BILT, CHERRY® and HUCK®
3/4" Nose Assemblies to: GB745/206-500SH

Installation Tool
(Sold Separately)

Catcher Bag-Stem

#756610

(Sold Separately)

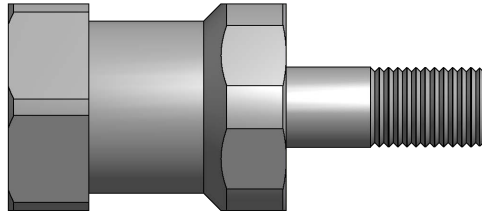

Catcher Bag-Stem

#704214

(Sold Separately)



Fill Bottle

#745263

(Sold Separately)



Air Bleeder Assy

#704153

(Sold Separately)



Grip Gage #GB105093

For NAS LOCKBOLTS and blind fasteners
(Sold Separately)



Gage Bilt also supplies pin & collar
swage inspection gages to certify
correct swage installation
(Sold Separately)



Alternative Styles

(Sold Separately)



GB745/206-500 SERIES

Stroke - .500" (12.7 mm)
Hand held weight - 2.0 lbs. (.91 kg)
Pull load - 4,800 (21.4 kN)



GB745/708LGP

Stroke - .500" (12.7 mm)
Hand held weight - 2.0 lbs. (.91 kg)
Pull load 5,600 (24.9 kN)



Alternative Styles

(Sold Separately)



GB745/204
Stroke - .500" (12.7 mm)
Hand held weight -1.5 lbs. (.68 kg)
Pull load 5,600 (24.9 kN)



GB745/205
Stroke - .550" (14.0 mm)
Hand held weight – 2.0 lbs. (.91 kg)
Pull load 7,085 (31.5 kN)





This page intentionally left blank

Riveter Kits Available

(Sold Separately)



Gage Bilt offers a wide selection of standard and custom kits tailored to your needs. Contact us for more information.



Split Riveter Tool Backpacks

For 5ft hose Split System Tools.

(Sold Separately)

SPLIT-SYSTEM TOOL BACKPACKS

- Backpack fits *any* split-system tool
- Reduces weight of tool by up to **70%**
- Reduces User Fatigue
- Increases Productivity
- Increases User Mobility
- Ergonomic
- Comfortable

INSIDE VIEW

OPTIONAL

Vacuum System for FOD Control

DEXRON® IS A REGISTERED TRADEMARK OF GENERAL MOTORS CORPORATION. TEFLON® IS A REGISTERED TRADEMARK OF E. I. DUPONT DE NEMOURS & CO. LUBRIPLATE® IS A REGISTERED TRADEMARK OF FISKE BROTHERS REFINING CO. SLIC-TITE® IS A REGISTERED TRADEMARK OF LA-CO INDUSTRIES INC. LOCTITE® IS A REGISTERED TRADEMARK OF HENKEL CORPORATION. CHERRYMAX® & CHERRYLOCK® ARE REGISTERED TRADEMARKS OF CHERRY AEROSPACE FASTENERS. HUCK® IS A REGISTERED TRADEMARK OF ARCONIC INC.