

GB751

INSTALLATION TOOL SERIES

GB751

Stroke - 0.780" (19.8 mm)
 Tool weight - 4.50 lbs. (2.04 kg)
 Pull load - 2,200 (9.79 kN)

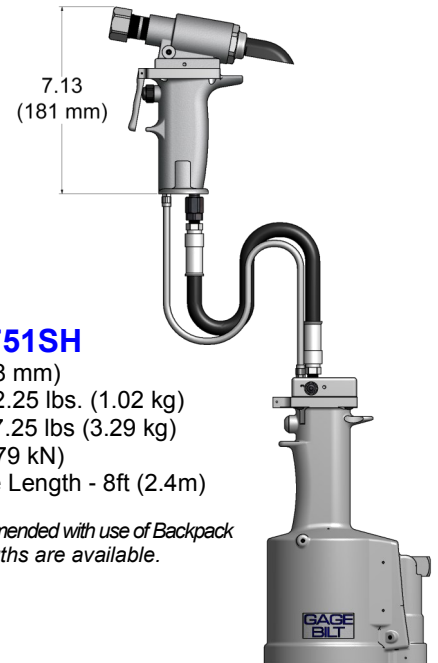
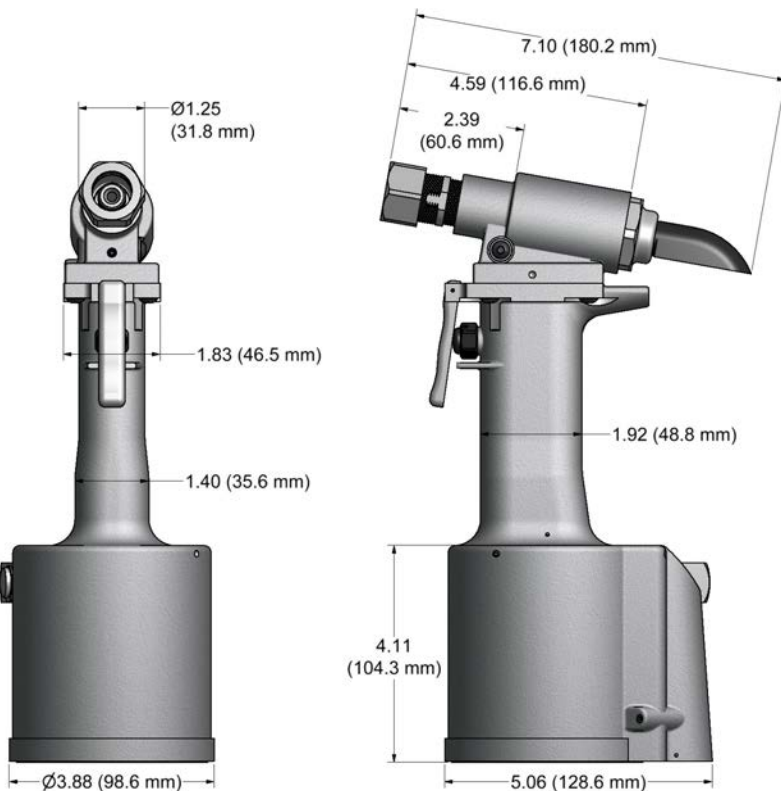

GB751SH

Stroke - 0.780" (19.8 mm)
 Hand held weight - 2.25 lbs. (1.02 kg)
 Entire tool weight - 7.25 lbs (3.29 kg)
 Pull load - 2,200 (9.79 kN)
 Standard Hyd. Hose Length - 8ft (2.4m)

*5ft Hyd. Hoses are recommended with use of Backpack
 Additional custom lengths are available.*

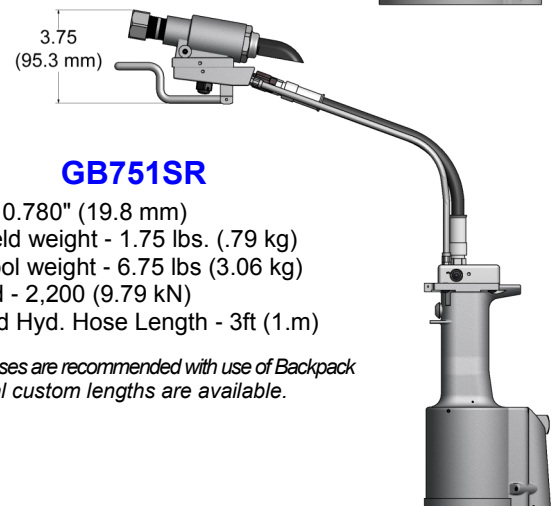

GB751SR

Stroke - 0.780" (19.8 mm)
 Hand held weight - 1.75 lbs. (.79 kg)
 Entire tool weight - 6.75 lbs (3.06 kg)
 Pull load - 2,200 (9.79 kN)
 Standard Hyd. Hose Length - 3ft (1.m)

*5ft Hyd. Hoses are recommended with use of Backpack
 Additional custom lengths are available.*

DESCRIPTION

The GB751 is a pneumatic-hydraulic tool designed specifically for the efficient installation of blind rivets. It weighs 4.5 lbs (2.04 kg) and can be operated in any position. It has a 0.780" (15.75mm) rivet setting stroke and a rated pull load of 2200 lbs (9.79 kN) with 90 psi (6.2 bar) air pressure at the air inlet.

The GB751SH and GB751SR riveters offer a unique "split" system providing the operator with an ergonomic tool with reduced hand held weight. The GB751SH comes with 8 feet (2.4 m) of hose and the GB751SR comes with 3 feet (1 m) of hose. Use with our "NEW" Split-System Backpacks to increase user mobility, ergonomics and productivity. Contact GAGE BILT for more information.

The GB751 tool series operate on 90 to 100 psi. (6.2-6.9 bar) of air pressure, with 90 psi. (6.2 bar) providing the maximum efficiency. At 90 psi. (6.2 bar) of air pressure, the GB751 series does not exceed 81.5 dB(A) and consumes .16 SCF/cycle (4.53 L/cycle) for the GB751 & GB751SR. The GB751SH consumes .30 SCF/cycle (8.50 L/cycle). The air inlet is provided with 1/4-18 female pipe thread to accept the users air hose fitting.

NOSE ASSEMBLIES ARE NOT FURNISHED WITH THIS RIVETER AND MUST BE ORDERED SEPARATELY.

GAGE BILT
 **MADE in USA**

INNOVATIVETOOLING
 On the leading edge of Aircraft Tooling

800-832-7009 

sales@innovativetooling.com 

innovativetooling.com 



GB751 NOSE ASSEMBLY SELECTION CHART & ACCESSORIES

ACCESSORIES

Catcher Bag-Stem Air Bleeder Assy
#704214 (Sold Separately) #704153 (Sold Separately)



Grip Gage #269G3
For CHERRYMAX®, "A" Code, NAS 1900 series and CHERRYLOCK® rivets (Sold Separately)



Gage Bilt also supplies pin & collar swage inspection gages to certify swage installation. (Sold Separately)

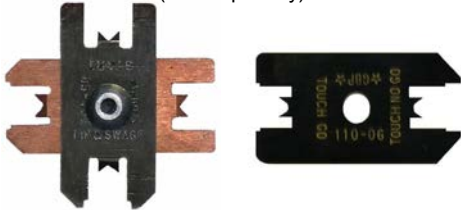

Riveter Kits
Gage Bilt offers a wide selection of standard and custom kits tailored to your needs. Contact us for more information. (Sold Separately)



Adapter Assy #751204

Adapts 204 offset series nose assemblies to GB751 installation tool. (Sold Separately)

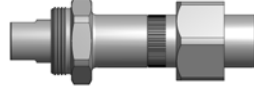

NOSE ASSEMBLIES

STRAIGHT
(Sold Separately)

RIGHT ANGLE
(Sold Separately)

OFFSET
(Sold Separately)



FASTENER	DIA.	STRAIGHT		RIGHT ANGLE	OFFSET
BLIND BOLT (SINGLE ACTION) WITH OR W/O DRIVE WASHER MS90353S & U / MS90354S & U MS21140S & U / MS21141S & U MAXIBOLT®, BACB30YY, YU, & YT HS5192	1/8 5/32	SB04-752C-20 SB04-752C-80	SB04-752C-45	SB04-751C-54RA	SB04-752B-43OS
BLIND BOLT (SINGLE ACTION) WITH DRIVE WASHER MS90353S & U / MS90354S & U MS21140S & U / MS21141S & U MAXIBOLT®, BACB30YY, YU, & YT HS5192	1/8 5/32	UBB04-752C-20 UBB04-752C-80	UBB04-752C-45	UBB04-751C-54RA	UBB04-752B-43OS
EN6122 & UAB130-EU EN6127 & UAB6127-EU EN6128 & UAB100-EU EN6129 & UABP-EU MAXIBOLT® PLUS	5/32 3/16 1/4	UAB568-713-21 ₄	UAB568-713-61 ₄		
UNIMATIC® BLIND RIVET (SINGLE ACTION) WITH OR W/O DRIVE WASHER NAS1900 S & U SERIES	1/8 5/32 3/16 1/4	SMLS04-752C-20 SMLS05-752C-20 SMLS06-752B-20 SMLS08-713-20	SMLS04-752C-45 SMLS05-752C-45 SMLS06-752B-45 SMLS08-713-45	SMLS04-751C-54RA SMLS05-751C-54RA SMLS06-751C-54RA SMLS08-713B-58RA ₆	SMLS04-752B-43OS SMLS05-752B-43OS SMLS06-752B-43OS SMLS08-752B-43OS ₃
UNIMATIC® BLIND RIVET (SINGLE ACTION) WITH DRIVE WASHER NAS1900 S & U SERIES	1/8 5/32 3/16 1/4	456UBR-751A-21 ₂ UBR08-713-20	456UBR-751A-61 ₂ UBR08-713-45	456UBR-751D-54RA ₂ SMLS08-713B-58RA ₆	456MAX-731-43OS ₂ UBR08-204D-27OS ₇ UBR08-204D-37OS ₇
"A" CODE NAS1398A & NAS1399A	3/32 1/8 5/32 3/16	3A-352B-25 4A-752C-20 5A-752C-20 6A-752B-20	4A-752C-45 5A-752C-45 6A-752B-45	3A-751C-54RA 4A-751C-54RA 5A-751C-54RA 6A-751C-54RA	3A-752B-43OS 4A-752B-43OS 5A-752B-43OS 6A-752B-43OS
NUT PLATE RIVETS CCR244/264/274 BACR15DR MS20600 HS5162	3/32 1/8	3NP-751-23 5N-751-23	3NP-352-61 5N-352-61	3NP-751B-54RA 45N-751B-54RA	3NP-751A-43OS 5N-751-43OS
CHERRYMAX®, CHERRYMAX® 'AB', BACR15FR/FP, BACR15GF/GK HS5902, HS6047, HS6048, M7885	1/8 5/32 3/16	456MAX-751-23 ₂ 06MAX-751-23VT ₂ (VT-Vacuum Tube only)	456MAX-751A-61 ₂	456MAX-751D-54RA ₂	456MAX-731-43OS ₂
ASP® ASP 2, ASP PF, ASP 4 FF, ASP 2 F, ASP 2 LC STANDARD MBC® NAS1719, NAS1720, NAS1721	13/64 1/8 5/32 3/16	ASP06-752C-20	ASP06-752C-45	ASP06-751B-54RA	ASP06-752B-43OS
MBC® LOCKCREATOR NAS1719X(L), NAS1720X(L), NAS1721X(L)	1/8 5/32 3/16	456MAX-751-23 ₂ 06MAX-751-23VT ₂ (VT-Vacuum Tube only)	456MAX-751A-61 ₂	456MAX-751D-54RA ₂	456MAX-731-43OS ₂
GROUND STUD, MB3454 & BACS53B ₅	8/32 10/32	GS8-752C-20 GS10-752B-20	GS8-752C-45 GS10-752B-45	GS8-751C-54RA GS10-752A-54RA	GS8-752B-43OS GS10-752C-43OS
POP® OPEN END NAIL RIVET	3/32 1/8 5/32 3/16	3N-751-23 4N-751-23 5N-751-23 6N-751-23	3N-352-61 4N-352-61 5N-352-61 6N-352-61	3N-751B-54RA 45N-751B-54RA 45N-751B-54RA 6N-751C-54RA	3N-751A-43OS 4N-751A-43OS 5N-751A-43OS 6N-751A-43OS
POP® CLOSED END NAIL RIVET (ALUMINUM MANDREL)	3/32 1/8 5/32 3/16	3N-751-23 4CEA-751-23 5CEA-751-23 6CEA-751-23	3N-352-61 4CEA-352-61 5CEA-352-61 6CEA-352-61	3N-751B-54RA 4CEA-751B-54RA 5CEA-751B-54RA 6CEA-751C-54RA	3N-751A-43OS 4CEA-751-43OS 5CEA-751-43OS 6CEA-751-43OS
POP® CLOSED END NAIL RIVET (STEEL MANDREL)	3/32 1/8 5/32 3/16	3N-751-23 4CES-751-23 5CES-751-23 6CES-751-23	3N-352-61 4CES-352-61 5CES-352-61 6CES-352-61	3N-751B-54RA 4CES-751B-54RA 5CES-751B-54RA 6CES-751C-54RA	3N-751A-43OS 4CES-751-43OS 5CES-751-43OS 6CES-751-43OS
FASTACK® AF5055	1/8 5/32 3/16	4C-752C-20 5C-752C-20 6C-752B-20	4C-752C-45 5C-752C-45 6C-752B-45	4C-751C-54RA 5C-751C-54RA 6C-751C-54RA	4C-751A-43OS 5C-751A-43OS 6C-751A-43OS
SUPERTACK® AF5075, AF5076, S149A020	1/8 5/32 3/16 1/4	3A-352B-25 4A-752C-20 5A-752C-20 6A-752B-20	4A-752C-45 5A-752C-45 6A-752B-45	3A-751C-54RA 4A-751C-54RA 5A-751C-54RA 6A-751C-54RA	3A-752B-43OS 4A-752B-43OS 5A-752B-43OS 6A-752B-43OS

UNIMATIC® AND ASP® ARE REGISTERED TRADEMARKS OF ARCONIC INC. CHERRYMAX®, MAXIBOLT® AND MBC® ARE REGISTERED TRADEMARKS OF CHERRY AEROSPACE. FASTACK® AND SUPERTACK® ARE REGISTERED TRADEMARKS OF ALLFAST FASTENING SYSTEMS INC. POP® IS A REGISTERED TRADEMARK OF EMHART

GAGE BILT CERTIFIES THE GB751 WILL INSTALL THE ABOVE FASTENERS

- RIGHT ANGLE NOSE ASSEMBLIES MAY REQUIRE MORE THAN ONE PULL.
- INSTALLS 1/8", 5/32" & 3/16" DIAMETERS.
- ALUMINUM ONLY.
- INSTALLS 5/32", 3/16" & 1/4" DIAMETERS.
- BACS53B -10 ONLY
- THESE NOSES FOR LIGHT DUTY / REPAIR ONLY. CONSULT GAGE BILT FOR HIGH PRODUCTION APPLICATIONS.
- NOSE ASSEMBLIES REQUIRE THE 751204 ADAPTER.

NOTE: THE LAST 2 DIGITS OF THE NOSE ASSEMBLY REPRESENTS THE LENGTH THE NOSE EXTENDS FROM THE TOOL. I.E. -20 = 2.0 INCHES