

# GB752

## INSTALLATION TOOL SERIES

### GB752

Stroke - 0.500" (12.7 mm)  
 Hand held weight - 4.75 lbs (2.2 kg)  
 Entire tool weight - 4.75 lbs (2.2 kg)  
 Pull load - 3,800 lbs.(16.9 kN)

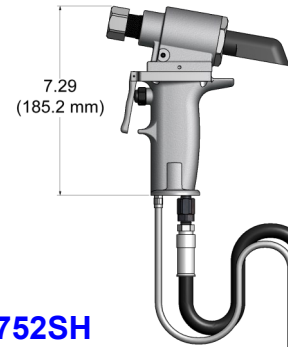
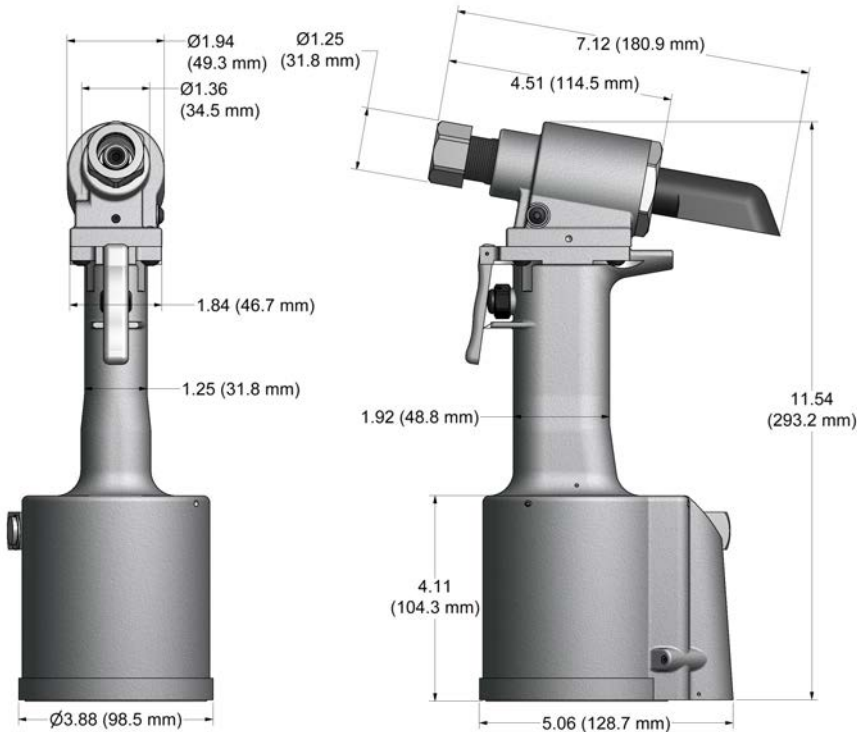

### GB752SH

Stroke - 0.500" (12.7 mm)  
 Hand held weight - 2.50 lbs (1.1 kg)  
 Entire tool weight - 7.50 lbs (3.4 kg)  
 Pull load - 3,800 lbs.(16.9 kN)  
 Standard Hyd. Hose Length - 8ft (2.4m)

*5ft Hyd. Hoses are recommended with use of Backpack  
 Additional custom lengths are available.*

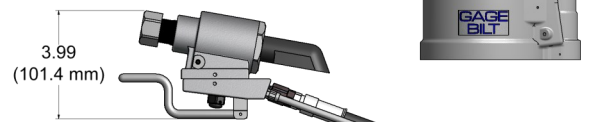

### GB752SR

Stroke - 0.500" (12.7 mm)  
 Hand held weight - 2.00 lbs (.9 kg)  
 Entire tool weight - 7.00 lbs (3.2 kg)  
 Pull load - 3,800 lbs.(16.9 kN)  
 Standard Hyd. Hose Length - 3ft (1.m)

*5ft Hyd. Hoses are recommended with use of Backpack  
 Additional custom lengths are available.*

## DESCRIPTION

The GB752 is a pneumatic-hydraulic tool designed specifically for the efficient installation of blind rivets. It weighs 4.75 lbs (2.2 kg) and can be operated in any position. It has a 0.500" (12.7mm) rivet setting stroke and a rated pull load of 3,800 lbs. (16.9 kN) with 90 psi (6.2 bar) air pressure at the air inlet.

The GB752SH and GB752SR riveters offer a unique "split" system providing the operator with an ergonomic tool with reduced hand held weight. The GB751SH comes with 8 feet (2.4 m) of hose and the GB751SR comes with 3 feet (1 m) of hose. Use with our "NEW" Split-System Backpacks to increase user mobility, ergonomics and productivity. Contact GAGE BILT for more information.

The GB752 tool series operate on 90 to 100 psi (6.2-6.9 bar) of air pressure, with 90 psi. (6.2 bar) providing the maximum efficiency. At 90 psi (6.2 bar) of air pressure, the GB752 series does not exceed 81.5 dB(A) and consumes .16 SCF/cycle (4.53 L/cycle) for the GB752 & GB752SR. The GB752SH consumes .30 SCF/cycle (8.50 L/cycle).

The air inlet is provided with 1/4-18 female pipe thread to accept the users air hose fitting.

**NOSE ASSEMBLIES ARE NOT FURNISHED WITH THIS RIVETER AND MUST BE ORDERED SEPARATELY.**

**GAGE BILT**  
 **MADE in USA**

**INNOVATIVETOOLING**  
 On the leading edge of Aircraft Tooling  
 800-832-7009  
 sales@innovativetooling.com  
 innovativetooling.com



# GB752 NOSE ASSEMBLY SELECTION CHART & ACCESSORIES

## ACCESSORIES

**AIR BLEEDER ASSY**  
#704153  
(Sold Separately)



**CATCHER BAG**  
#704214  
(Sold Separately)



### Grip Gage #269G3

For CHERRYMAX® and CHERRYLOCK® rivets  
(Sold Separately)



### Grip Gage #GB105093

For NAS LOCKBOLTS and blind fasteners  
(Sold Separately)



Gage Bilt also supplies pin & collar swage inspection gages to certify swage installation.  
(Sold Separately)

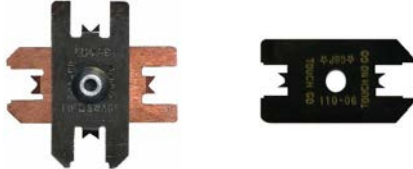

### Riveter Kits

Gage Bilt offers a wide selection of standard and custom kits tailored to your needs  
Contact us for more information.  
(Sold Separately)



## STRAIGHT (Sold Separately)

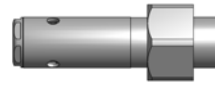

## RIGHT ANGLE (Sold Separately)



## OFFSET (Sold Separately)



FASTENER	DIA.	STRAIGHT	*RIGHT ANGLE	**OFFSET	
COMMERCIAL LOCKBOLTS	3/16 1/4	LB06-722-20 LB08-722-20	LB06-722-60 LB08-722-60		
MULTI-GRIP LOCKBOLTS	3/16 1/4	MG06-722-20 MG08-722-20	MG06-722-60 MG08-722-60		
BLIND BOLT (SINGLE ACTION) WITH OR W/OUT DRIVE WASHER MS90353S & U / MS90354S & U MS21140S & U / MS21141S & U MAXIBOLT®, BACB30YY, YU, & YT	1/8 5/32 3/16	SB04-752C-20 SB05-752C-20 SB05-752C-80 SB06-752B-20 SB06-752B-80	SB04-752C-45 SB05-752C-45 SB06-752B-45	SB04-751C-54RA SB05-751C-54RA SB06-751B-54RA	SB04-752B-43OS SB05-752A-43OS SB06-204D-27OS
BLIND BOLT (SINGLE ACTION) WITH DRIVE WASHER MS90353S & U / MS90354S & U MS21140S & U / MS21141S & U MAXIBOLT®, BACB30YY, YU, & YT	1/8 5/32 3/16	UBB04-752C-20 UBB05-752C-20 UBB05-752C-80 UBB06-752B-20 UBB06-752B-80	UBB04-752C-45 UBB05-752C-45 UBB06-751B-54RA	UBB04-751C-54RA UBB05-751C-54RA UBB06-751B-54RA	UBB04-752B-43OS UBB05-752B-43OS UBB06-204D-27OS
EN6122 & UAB130-EU EN6127 & UAB6127-EU EN6128 & UAB100-EU EN6129 & UABP-EU MAXIBOLT® PLUS	5/32 3/16	UAB05-752C-20 UAB06-752B-20	UAB05-752C-45 UAB06-752B-45	UAB05-751C-54RA UAB06-751B-54RA	UAB05-752B-43OS UAB06-752B-43OS
UNIMATIC® BLIND RIVET (SINGLE ACTION) WITH OR W/OUT DRIVE WASHER NAS1900 S & U SERIES	1/8 5/32 3/16 1/4	SML504-752C-20 SML505-752C-20 SML506-752B-20 SML508-713-20	SML504-752C-45 SML505-752C-45 SML506-752B-45 SML508-713-45	SML504-751C-54RA SML505-751C-54RA SML506-751C-54RA SML508-713-54RA	SML504-752B-43OS SML505-752B-43OS SML506-752B-43OS SML508-204D-27OS
UNIMATIC® BLIND RIVET (SINGLE ACTION) WITH DRIVE WASHER NAS1900 S & U SERIES	1/8 5/32 3/16 1/4	456UBR-751A-21 UBR08-713-20	456UBR-751A-61 UBR08-713-45	456UBR-751D-54RA UBR08-751B-54RA	456MAX-731-43OS UBR08-204D-27OS UBR08-204D-37OS
"A" CODE NAS1398A & NAS1399A	3/32 1/8 5/32 3/16 1/4	3A-352B-25 4A-752C-20 5A-752C-20 6A-752B-20 SML508-713-20	4A-752C-45 5A-752C-45 6A-752B-45	3A-751C-54RA 4A-751C-54RA 5A-751C-54RA 6A-751C-54RA	4A-752B-43OS 5A-752B-43OS 6A-752B-43OS SML508-204D-27OS
NUT PLATE RIVETS CCR244/264/274 BACR15DR MS20600	3/32 1/8	3NP-751-23 5N-751-23	3NP-352-61 5N-352-61	3NP-751B-54RA 45N-751B-54RA	3NP-751-43OS 5N-751-43OS
CHERRYMAX®, CHERRYMAX® 'AB', BACR15FR/FP, BACR15GF/GK	1/8 5/32 3/16 1/4	456MAX-751-23 08MAX-752B-20	456MAX-751A-61 08MAX-752B-45	456MAX-751D-54RA	456MAX-731-43OS **08MAX-204D-27OS **08MAX-204D-37OS
ASP® ASP 2, ASP PF, ASP 4 FF, ASP 2 F, ASP 2 LC	13/64 17/64	ASP06-752B-20 ASP08-752B-20	ASP06-752B-45 ASP08-752B-45	ASP06-751B-54RA	ASP06-752B-43OS ASP08-752B-43OS
STANDARD MBC® NAS1719, NAS1720 NAS1721	1/8 5/32 3/16	MBC04-752C-20 MBC05-752C-20 MBC06-752B-20	MBC04-752C-45 MBC05-752C-45 MBC06-752B-45	MBC04-751C-54RA MBC05-751C-54RA MBC06-751C-54RA	MBC04-752C-43OS MBC05-752C-43OS MBC06-752C-43OS
MBC® LOCK CREATOR NAS1719X(L), NAS1720X(L) NAS1721X(L)	1/8 5/32 3/16	456MAX-751-23 GS8-752B-20 GS10-752B-20	456MAX-751A-61 GS8-752B-45 GS10-752B-45	456MAX-X-751D-54RA GS8-751C-54RA GS10-752A-54RA	456MAX-731-43OS GS8-752B-43OS GS10-752B-43OS
GROUND STUD, M83454 & BACS53B	8/32 10/32	GS8-752B-20 GS10-752B-20	GS8-752B-45 GS10-752B-45	GS8-751C-54RA GS10-752A-54RA	GS8-752B-43OS GS10-752B-43OS
POP® OPEN END NAIL RIVET	3/32 1/8 5/32 3/16	3N-751-23 4N-751-23 5N-751-23 6N-751-23	3N-352-61 4N-352-61 5N-352-61 6N-352-61	3N-751B-54RA 45N-751B-54RA 45N-751B-54RA 6N-751C-54RA	3N-751A-43OS 4N-751A-43OS 5N-751A-43OS 6N-751A-43OS
POP® CLOSED END NAIL RIVET (ALUMINUM MANDREL)	3/32 1/8 5/32 3/16	3N-751-23 4CEA-751-23 5CEA-751-23 6CEA-751-23	3N-352-61 4CEA-352-61 5CEA-352-61 6CEA-352-61	3N-751B-54RA 45CEA-751B-54RA 45CEA-751B-54RA 6CEA-751C-54RA	3N-751A-43OS 4CEA-751-43OS 5CEA-751-43OS 6CEA-751-43OS
POP® CLOSED END NAIL RIVET (STEEL MANDREL)	3/32 1/8 5/32 3/16	3N-751-23 4CES-751-23 5CES-751-23 6CES-751-23	3N-352-61 4CES-352-61 5CES-352-61 6CES-352-61	3N-751B-54RA 4CES-751B-54RA 5CES-751B-54RA 6CES-751C-54RA	3N-751A-43OS 4CES-751-43OS 5CES-751-43OS 6CES-751-43OS

CHERRYMAX®, T RIVETS®, MAXIBOLT® AND MBC® ARE REGISTERED TRADEMARKS OF CHERRY AEROSPACE FASTENERS. AVEX®, KLAMP-TITE®, TUB®, HELICOIL® AND MCONBOLT® ARE REGISTERED TRADEMARKS OF AVDEL UK LIMITED. ASP®, MAGNA-LOK®, UNIMATIC® AND MAGNA-BULB® ARE REGISTERED TRADEMARKS OF ARCONIC INC. BULB-TITE® IS A REGISTERED TRADEMARK OF GESIPA FASTENERS USA, INC. ULTRA-GRIP® AND POP® ARE REGISTERED TRADEMARKS OF EMHART TECHNOLOGIES.

### GAGE BILT CERTIFIES THE GB752 WILL INSTALL THE ABOVE FASTENERS

- \*ALL RIGHT ANGLE NOSES REQUIRE 752142 STROKE LIMITER.
- \*\*ALL OFFSET 204 SERIES NOSES REQUIRE 751204 ADAPTER.
- 1) RIGHT ANGLE NOSE ASSEMBLY'S MAY REQUIRE MORE THAN ONE PULL.
- 2) INSTALLS 1/8, 5/32 & 3/16 DIAMETERS
- 3) INSTALLS 5/32 & 3/16 DIAMETERS
- 4) BACS53B -10 ONLY
- 5) TWO PULLS MAY BE REQUIRED FOR 1/4" DIAMETER MULTI-GRIP LOCKBOLTS
- 6) THESE NOSES FOR LIGHT DUTY / REPAIR ONLY. CONSULT GAGE BILT FOR HIGH PRODUCTION APPLICATIONS.

NOTE: THE LAST 2 DIGITS OF THE NOSE ASSEMBLY REPRESENTS THE LENGTH THE NOSE EXTENDS FROM THE TOOL. I.E. -20 = 2.0 INCHES  
GB752SR MODELS MUST USE -45 LENGTH OR LONGER ON ALL 752 STYLE NOSES

### Adapter Assy #751204

Adapts 204 offset series nose assemblies to GB752 installation tool.  
(Sold Separately)

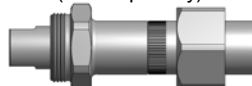

Other adapters available. Contact Gage Bilt for more information.

### Adapter Assy #730715

Adapts GB715 Series Nose Assemblies to: Gage Bilt GB752, GB730, GB713, GB731 & GB722  
(Sold Separately)

