

ORIGINAL INSTRUCTIONS

S/N: 1226 AND ABOVE
PLEASE CONTACT GAGE BILT FOR
ALL OTHER SERIAL NUMBERS.

GB756

INSTALLATION TOOL

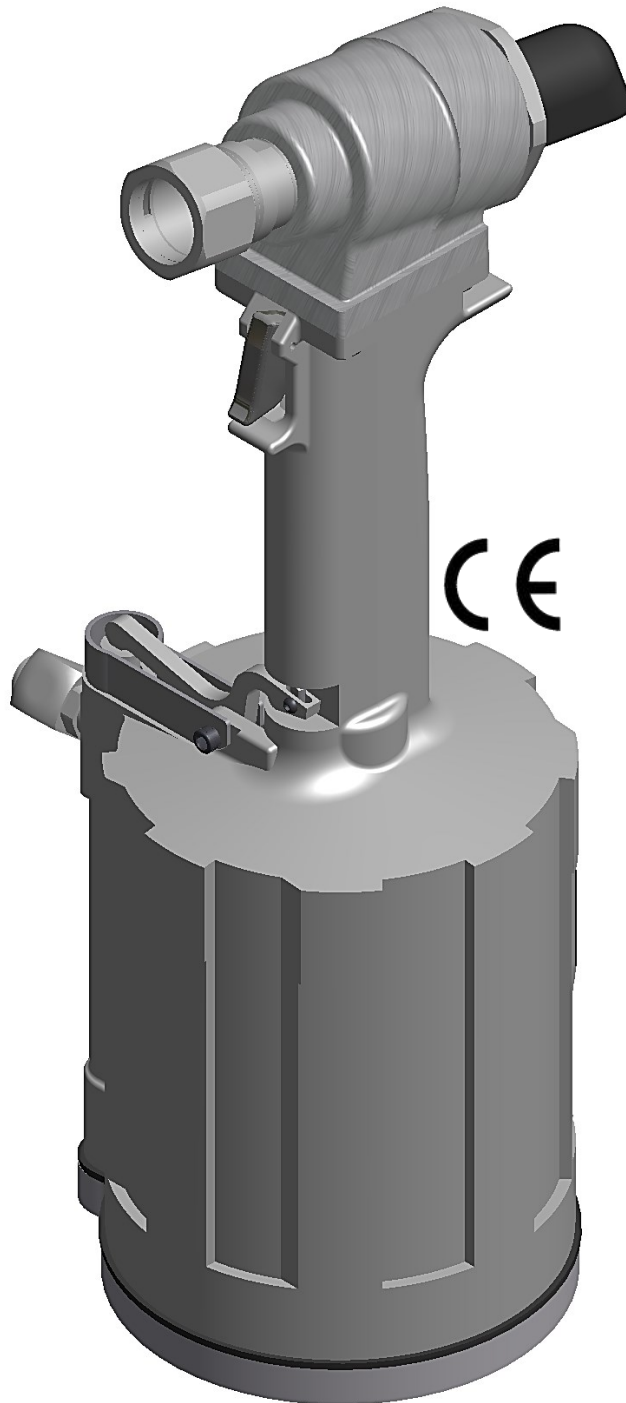

GAGE BILT
 **MADE in USA**

INNOVATIVETOOLING
On the leading edge of Aircraft Tooling

800-832-7009 

sales@innovativetooling.com 

innovativetooling.com 



	<u>Page</u>
EU Conformity and Warranty	3
Description and Technical Specifications	4
Description of Functions	5
Safety Warnings	6
Principle of Operation.....	7
How to set-up the GB756.....	8 & 9
How to use the GB756	10
Maintenance	11
Filling	12
Bleeding and Stroke Chart.....	13
Troubleshooting	14
Overhaul	15-16
Parts Lists.....	17
DEXRON® III Oil Safety Data (SDS)	18
Nose Assembly Selection Chart / Accessories	19-24



DECLARATION OF CONFORMITY

MANUFACTURER: Gage Bilt Inc. 44766 Centre Ct. Clinton Twp. Michigan U.S.A. +1(586-226-1500)

WE DECLARE THAT THE EQUIPMENT SPECIFIED HEREIN CONFORMS TO THE FOLLOWING DIRECTIVES AND STANDARDS

Machinery Directive 2006/42/EC

EN12100-1 & 12100-2:2010

EN ISO 11148-1:2011

EU REPRESENTATIVE: Edgar Hausmann GmbH Förster-Busch-Str. 10 D-34346 Hann. Münden Germany

EQUIPMENT DESCRIPTION: GB756 FASTENER INSTALLATION TOOL

This product specified above conforms to the above directives and standards.

SIGNATURE:

NAME: BRIAN LEIGH
PRODUCT MANAGER
CLINTON TWP., MI U.S.A.
SEPT 2012
+1(586) 226-1500

WARRANTY

Seller warrants that all goods covered by this catalog will conform to applicable specifications and will replace or repair, EXW our plant, any goods providing defective from faulty workmanship, or material, for 1 year from date of shipment.

Said warranty to remain in effect if, and only if, such goods are used in accordance with all instructions as to maintenance, operation and use, set forth in manuals and instruction sheets furnished by seller.

Sellers obligation under this warranty shall be limited to the repair or rework of the goods supplied or replacement thereof, at Seller's option, and in no case is to exceed the invoice value of said goods. Under no circumstances will the seller be liable for incidental or consequential damages or for damages incurred by the buyer or subsequent user in repairing or replacing defective goods or if the goods covered by this warranty are reworked or subjected to any type of additional processing.

This warranty is void if Seller is not notified in writing of any rejections or defects within 1 year after the receipt of the material by the customer.

THIS WARRANTY IS MADE IN LIEU OF ALL OTHER WARRANTIES EXPRESSED OR IMPLIED, INCLUDING MERCHANTABILITY.

DESCRIPTION



⚠ WARNING: Any other use is forbidden.

The GB756 is a pneumatic installation tool designed specifically for the efficient installation of blind, lockbolt and Magna-Grip® fasteners thru 3/8" diameter.

It weighs 11.1 lbs. (5.0kg) and can be operated in any position. It has a .960" (24.4mm) fastener setting stroke and a rated pull load of 10,000 lbs. (44.5kN).

The GB756 installation tool operates on 90 to 100 psi (6.2-6.9 bar) Max. of air pressure. At 90 psi. (6.2 bar) of air pressure, the GB756 does not exceed 81.5 dB(A) and consumes .29 SCF/cycle (8.21 L/cycle).

The air inlet is provided with 1/4-18 female pipe thread for accepting the user's air hose fitting.

Nose Assemblies that were designed for the model 353 installation tool mount directly on the GB756 without the use of an adapter.

Nose Assemblies that were designed for the model 352 installation tool will attach to the GB756 with the use of the 745751 nose assembly adapter.

NOSE ASSEMBLIES ARE NOT FURNISHED WITH THIS TOOL AND MUST BE ORDERED SEPARATELY (SEE NOSE ASSEMBLY SELECTION CHART PG. 19).

ENVIRONMENTAL USE

⚠ WARNING: Do not operate in an explosive atmosphere.

The GB756 can be operated between 0°F - 118°F (-17.8°C / 47.8°C)

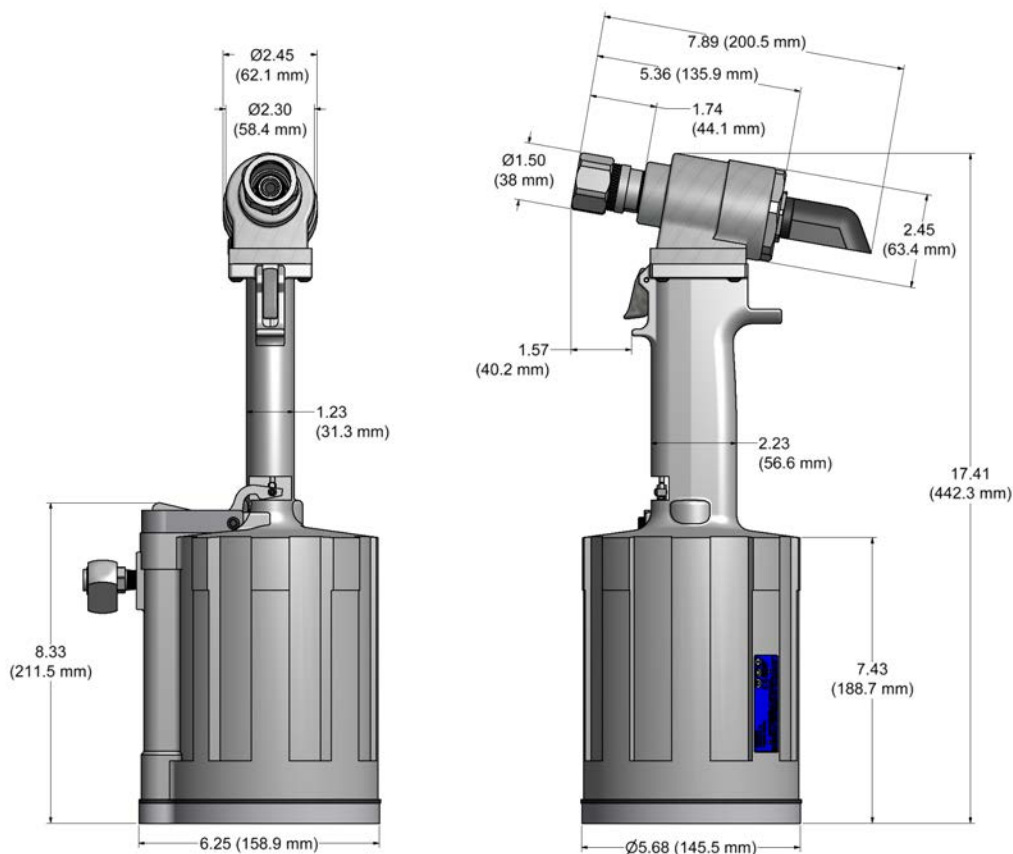

TECHNICAL SPECIFICATIONS

Hand Held Weight	- 11.1 lbs (5.0 kg).
Air pressure req'd	- 90-100 p.s.i. (6.2-6.9 bar) Max.
Air consumption	- .29 SCF/cycle (8.21 L/cycle)
Hydraulic Oil	- Automatic Transmission Oil, Dexron® III, or equivalent.
Setting stroke	- .960" (24.4mm)
Rated pull load	- 10,000 lbs. (44.5kN)
Noise level	- 94.3 dB(A) Peak
Vibration	- Tested– No hazards found.

DESCRIPTION OF FUNCTIONS

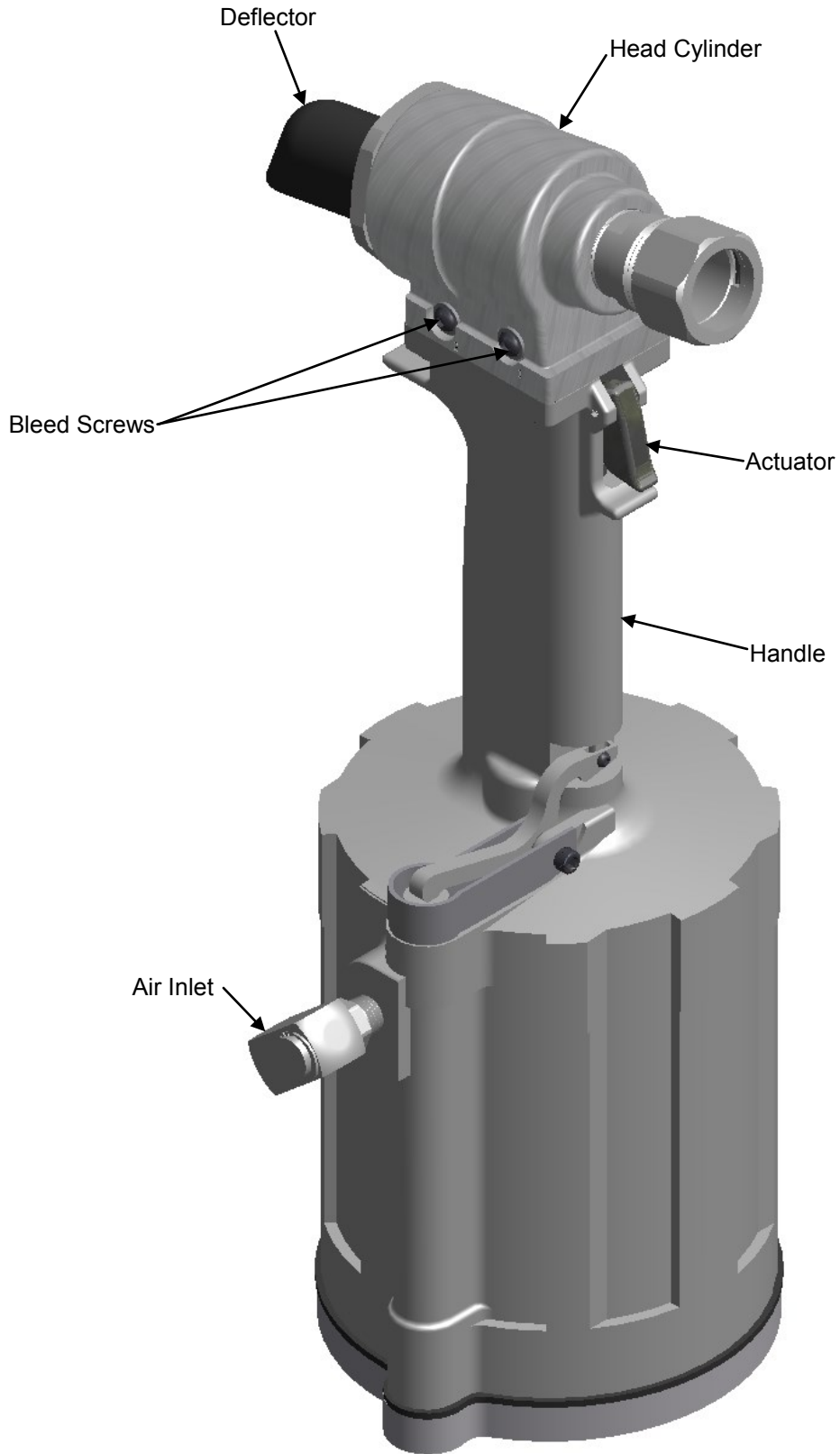

Image may not reflect actual tool



TERMS AND SYMBOLS



- Product complies with requirements



- Hearing protection and eye protection



- Read manual prior to using equipment



- Foot protection



WARNINGS - Must be understood to avoid severe personal injury.



CAUTIONS - show conditions that will damage equipment and/or structure.

Notes - are reminders of required procedures.

GENERAL SAFETY RULES:

1. For multiple hazards, read and understand the safety instructions before installing, operating, repairing, maintaining, changing accessories on, or working near the assembly power tool for non-threaded mechanical fasteners.
2. Only qualified and trained operators should install, adjust or use the assembly power tool for non threaded mechanical fasteners.
3. Do not modify this assembly power tool for non-threaded mechanical fasteners. Modifications can reduce effectiveness of safety measures and increase the risks to the operator.
4. Do not discard safety instructions; give them to the operator.
5. Do not use assembly power tool for non-threaded mechanical fasteners if it has been damaged.
6. Tools shall be inspected periodically to verify all ratings and markings required are legible. The employer/user shall contact the manufacturer to obtain replacement marking labels when necessary.
7. Air under pressure can cause severe injury.
8. Always shut off air supply, drain hose of air pressure and disconnect tool from air supply when not in use, before changing accessories or when making repairs.
9. Never direct air at yourself or anyone else.
10. Whipping hoses can cause severe injury. Always check for damage or loose hoses and fittings.
11. Cold air shall be directed away from hands.
12. Whenever universal twist couplings (claw couplings) are used, lock pins shall be installed and whipcheck safety cables shall be used to safeguard against possible hose-to-tool or hose-to-hose connection failure.
13. Do not exceed the maximum air pressure stated on the tool or manual.
14. Never carry an air tool by the hose.

ADDITIONAL SAFETY RULES FOR PNEUDRAULIC POWER TOOLS:

1. Air under pressure can cause severe injury.
2. Always shut off air supply, drain hose of air pressure and disconnect tool from air supply when not in use, before changing accessories or when making repairs.
3. Never direct air at yourself or anyone else.
4. Whipping hoses can cause severe injury. Always check for damage or loose hoses and fittings.
5. Cold air shall be directed away from hands.
6. Whenever universal twist couplings (claw couplings) are used, lock pins shall be installed and whipcheck safety cables shall be used to safeguard against possible hose-to-tool or hose-to-hose connection failure.
7. Do not exceed the maximum air pressure stated on the tool or manual.
8. Never carry an air tool by the hose.

PROJECTILE HAZARDS:

1. Disconnect the tool from the energy source when changing inserted tools/nose assemblies or accessories.
2. Be aware that failure of the workpiece or accessories, or even the inserted tool/nose assembly itself can generate high-velocity projectiles.
3. Always wear impact resistant eye protection during operation of the tool. The grade of protection required should be assessed for each use.
4. The risk to others should also be assessed at this time.
5. Ensure that the workpiece is securely fixed.
6. Check that the means of protection from ejection of fastener and/or stem is in place and operative (such as the deflector).
7. Forcible ejection of the mandrel from the front of the nose assembly is possible.

OPERATING HAZARDS:

1. Use of tool can expose the operator's hands to hazards, including crushing, impacts, cuts, abrasions and heat. Wear suitable gloves to protect hands.
2. Operators and maintenance personnel shall be physically able to handle the bulk, weight and power of the tool.
3. Hold the tool correctly; be ready to counteract normal or sudden movements and have both hands available.
4. Maintain a balanced body position and secure footing.
5. Release the start-and-stop device in the case of interruption of energy supply.
6. Use only lubricants recommended by the manufacturer.
7. Avoid unsuitable postures as it is likely for these positions not to allow counteracting of normal or unexpected movement of the tool.
8. If the tool is fixed to a suspension device, make sure that fixation is secure.
9. Beware of the risk of crushing or pinching if nose equipment is not fitted.
10. Due to the tool weight, it is recommended safety shoes be worn during operation.
11. It is recommended tool be operated not more than 50 out of every 60 minutes, where prolonged use is expected.

REPETITIVE MOTIONS HAZARDS:

1. When using the tool, the operator can experience discomfort in the hands, arms, shoulders, neck or other parts of the body.
2. While using the tool, the operator should adopt a comfortable posture while maintaining a secure footing and avoiding awkward or off balanced postures. The operator should change posture during extended tasks; this can help avoid discomfort and fatigue.
3. If the operator experiences symptoms such as persistent or recurring discomfort, pain, throbbing, aching, tingling, numbness, burning sensations or stiffness, these warning signs should not be ignored. The operator should tell the employer and consult a qualified health professional.

ACCESSORY HAZARDS:

1. Disconnect tool from energy supply before changing the nose assembly or accessory.
2. Use only sizes and types of accessories recommended by the manufacturer. Do not use other types or sizes of accessories.

WORKPLACE HAZARDS:

1. Slips, trips and falls are major causes of workplace injury. Be aware of slippery surfaces caused by use of tool and also of trip hazards caused by the air line or hydraulic hose.
2. Proceed with care in unfamiliar surroundings. There could be hidden hazards, such as electricity or other utility lines.
3. The tool is not intended for use in potentially explosive atmospheres and is not insulated against contact with electrical power.
4. Ensure that there are no electrical cables, gas pipes, etc., which can cause a hazard if damaged by the tool.

NOISE HAZARDS:

1. Exposure to high noise levels can cause permanent, disabling hearing loss and other problems, such as tinnitus (ringing, buzzing, whistling or humming in the ears). Therefore, risk assessment and the implementation of appropriate controls for these hazards are essential.
2. Appropriate controls to reduce the risk may include actions such as damping materials to prevent workpieces from "ringing".
3. Use hearing protection in accordance with employer's instructions and as required by occupational health and safety regulations.
4. Operate and maintain the assembly power tool for non-threaded mechanical fasteners as recommended in the instruction handbook, to prevent an unnecessary increase in the noise level.
5. Select, maintain and replace the consumable/inserted tool as recommended in the instruction handbook, to prevent an unnecessary increase in noise.
6. If the power tool has a silencer, always ensure that it is in place and in good working order when the power tool is being operated.

VIBRATION HAZARDS:

1. Exposure to vibration can cause disabling damage to the nerves and blood supply of the hands and arms.
2. Wear warm clothing when working in cold conditions and keep your hands warm and dry.
3. If you experience numbness, tingling, pain or whitening of the skin in your fingers or hands, stop using the assembly power tool for non-threaded mechanical fasteners, tell your employer and consult a physician.
4. Support the weight of the tool in a stand, tensioner or balancer, because a lighter grip can then be used to support the tool.

PRINCIPLE OF OPERATION



When the actuator is depressed, the throttle valve is shifted, directing the pressurized air inside the tool to the bottom of the air piston assy, moving it in an upward direction. The air above the air piston assy is then directed out the exhaust, on the bottom of the tool. Simultaneously, the piston rod assy connected to the air piston assy is also moving up, forcing hydraulic oil up and into the front of the head cylinder, causing the piston assy to move to the rear of the head cylinder. The oil from the rear of the head cylinder is directed to the bottom of the piston rod assembly, inside the handle assy. The internal components of the attached nose assembly are also moving with the piston assy to start the fastener installation. When the fastener installation is completed the actuator is released allowing spring pressure to move the throttle back to the original position, directing the air pressure to the top side of the air piston assy and reversing the sequence.

PNEUDRAULIC DIAGRAM

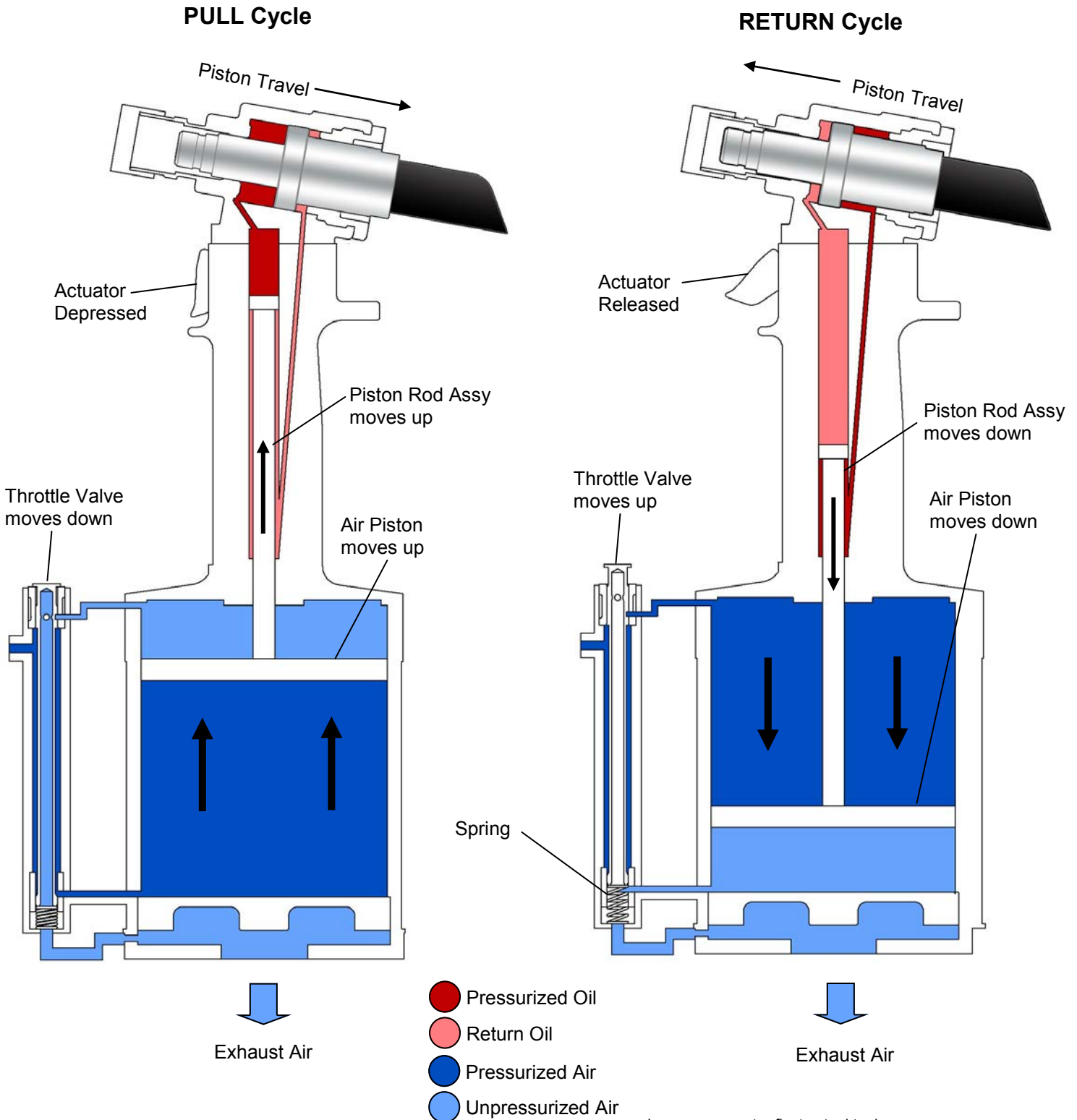

Images may not reflect actual tool

HOW TO SET-UP THE GB756



- ⚠ WARNING:** Only qualified and trained operators should install, adjust or use the assembly power tool for non-threaded mechanical fasteners.
- ⚠ WARNING:** Operator **MUST** read and understand all warnings and cautions.
- ⚠ WARNING:** It is required that eye protection, hearing protection and safety boots be worn at all times while handling this equipment.
- ⚠ WARNING:** The users or the user's employer should assess specific risks that could be present as a result after each use based on their application.
 - *Be sure there is adequate clearance for tool and operator's hands before proceeding. Keep fingers clear of any moving parts. Keep fingers clear from fasteners and installed materials. Severe personal injury may result.*
 - *Verify the air lines and/or hydraulic hoses are not a trip hazard.*
 - *Ensure that there are no electrical cables, gas pipes, etc., which can cause a hazard if damaged by the tool*
- ⚠ WARNING:** Do not pull fastener in the air. Personal injury from fastener ejecting may occur.
- ⚠ WARNING:** Air is exhausted from the bottom of the tool. Direct bottom of the tool (exhausted air) away from operator, other persons working in the vicinity, foreign matter and liquid.
- ⚠ WARNING:** Do not carry from hoses or use as a hammer.
- ⚠ WARNING:** Do not use in explosive atmosphere.
- ⚠ WARNING:** Ensure air hose is securely connected to avoid possible hose whipping.
- ⚠ WARNING:** Always disconnect air supply when tool is not in use to prevent accidental start-up.
- ⚠ WARNING:** Be sure there is adequate clearance for tool and operator hands.
- ⚠ CAUTION:** Do not use beyond the design intent.

The tool is shipped with a red plastic plug in the air inlet connector. The connector has a 1/4-18 NPT female pipe thread to accept end-user air hose fitting. The tool comes with oil and is ready to use.

1. Remove red plastic shipping pipe plug (A-204) from air inlet swivel (A-249) and screw in your quick disconnect (air) fitting.
2. Attach Deflector (756120) to rear of Head Cylinder (756300).
3. Connect tool to air hose with 90 psi. (6.2 bar) using clean, dry air. 3/8 minimum diameter air line is recommended. Cycle tool five times by depressing and releasing actuator (756142).
4. Disconnect air hose from tool.
5. Select proper nose assembly and stroke limiter (if applicable) (see nose selection chart pg. 19). For further information see pages 9 & 19. Screw collet assy onto piston assy and slide anvil over collet, secure with retaining nut stop (480125) and retaining nut (480124). (See proper data sheet for further instructions.)
6. Connect air supply.

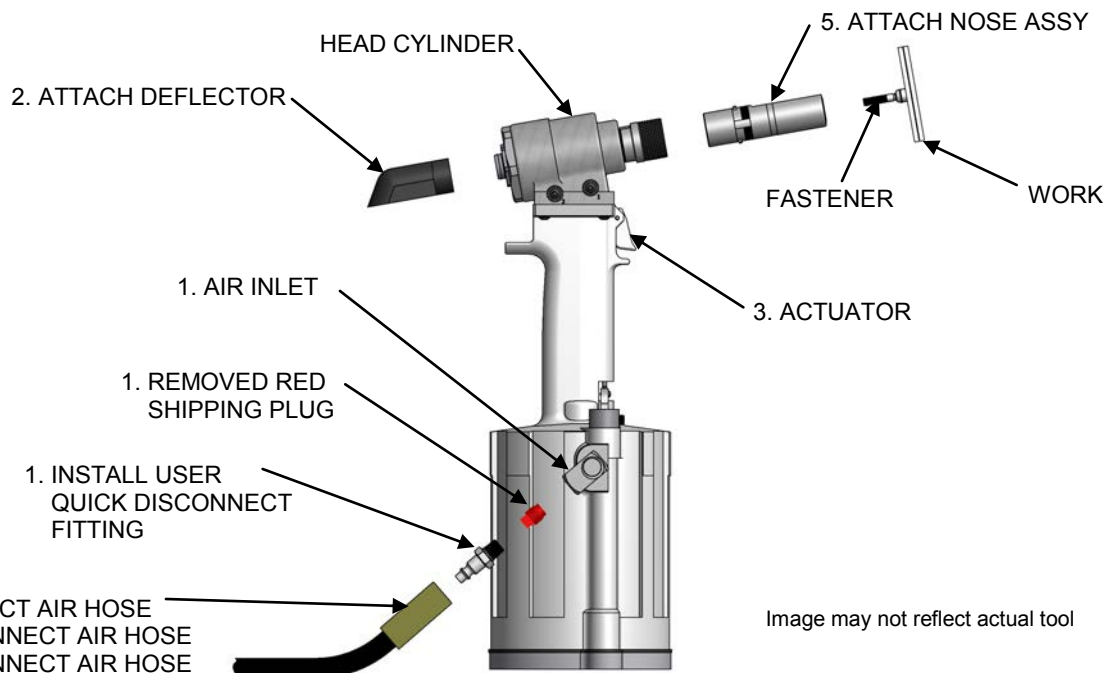

NOSE ASSEMBLIES



Nose assemblies are attached using a 1-1/4 inch socket on the rear of the piston assy. Socket (A-1307) may be ordered separately from Gage Bilt. (GB756TK) tool kit may also be ordered separately which includes socket (A-1307) and other tools needed for complete tool overhaul.

When attaching offset and right angle nose assemblies an adapter and stroke limiter is necessary. Refer to nose assembly selection chart on pg 19 for the adapter and stroke limiter for your specific nose assembly. Follow instructions below for installation of stroke limiter.

STROKE LIMITERS ARE DESIGNED FOR THE PROTECTION OF THE OPERATOR AND EQUIPMENT. FAILURE TO OPERATE TOOL WITHOUT A STROKE LIMITER WILL RESULT IN DAMAGE TO NOSE ASSEMBLY OR TOOL AND MAY RESULT IN PERSONAL INJURY. IF UNSURE YOUR NOSE ASSEMBLY REQUIRES A STROKE LIMITER CONTACT GAGE BILT.

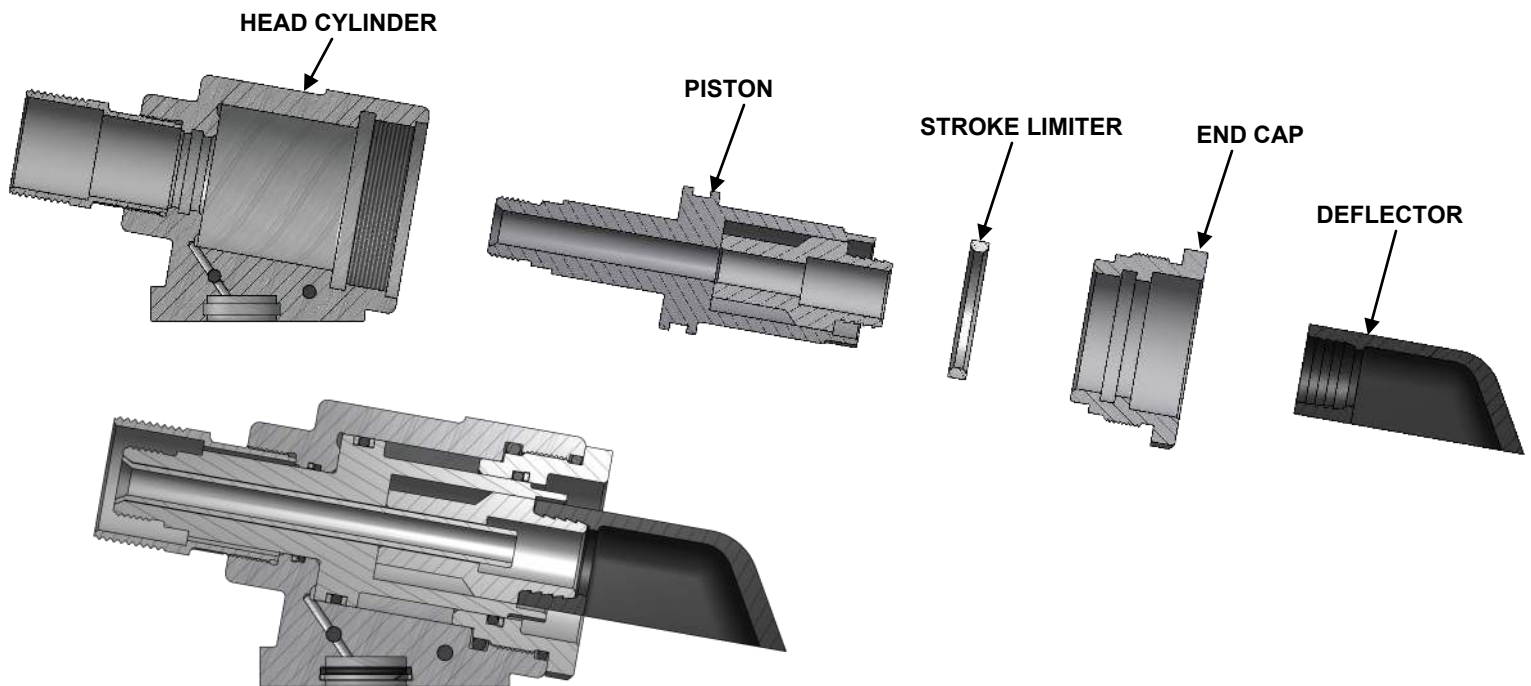

STROKE LIMITER INSTRUCTIONS

1. Disconnect air supply from tool.
2. Remove rear bleeder screw (marked #2). **CAUTION:** Rear bleeder screw (marked #2) may be under pressure.
3. Remove deflector (756120) and end cap (756116). **CAUTION:** Pour hydraulic oil into a container.
4. Slide stroke limiter over the rear of the piston assy (756211).
5. Tighten end cap onto head cylinder and re-attach deflector (756120). See torque spec.
6. Attach air bleeder assy (704153) to rear hole.
7. With front button head screw (marked #1) and stat-o-seal torqued to 35-40 inch pounds, (do not over tighten), and the air bleeder assy (704153) attached to rear hole (marked #2), connect tool to air with the pressure being set at 40-50 psi. (2.76 to 3.45 bar).
8. Cycle tool ten times, holding actuator down for 5 seconds and releasing the actuator for 5 seconds.
9. Depress actuator and hold until piston assy (756211) is in its full rear position. While still holding actuator, disconnect air supply.
10. Remove air bleeder assy (704153) and install rear button head screw (402482) and stat-o-seal (A-1155) on head cylinder (756300) hole marked #2.
11. Refer to bleeding procedure on pg13, step #1.



- ⚠ WARNING:** Only qualified and trained operators should install, adjust or use the assembly power tool for non-threaded mechanical fasteners.
- ⚠ WARNING:** Operator **MUST** read and understand all warnings and cautions.
- ⚠ WARNING:** It is required that eye protection, hearing protection and safety boots be worn at all times while handling this equipment.
- ⚠ WARNING:** The users or the user's employer should assess specific risks that could be present as a result after each use based on their application.
 - *Be sure there is adequate clearance for tool and operator's hands before proceeding. Keep fingers clear of any moving parts. Keep fingers clear from fasteners and installed materials. Severe personal injury may result.*
 - *Verify the air lines and/or hydraulic hoses are not a trip hazard.*
 - *Ensure that there are no electrical cables, gas pipes, etc., which can cause a hazard if damaged by the tool*
- ⚠ WARNING:** Do not pull fastener in the air. Personal injury from fastener ejecting may occur.
- ⚠ WARNING:** Air is exhausted from the bottom of the tool. Direct bottom of the tool (exhausted air) away from operator, other persons working in the vicinity, foreign matter and liquid.
- ⚠ WARNING:** Do not carry from hoses or use as a hammer.
- ⚠ WARNING:** Do not use in explosive atmosphere.
- ⚠ WARNING:** Ensure air hose is securely connected to avoid possible hose whipping.
- ⚠ WARNING:** Always disconnect air supply when tool is not in use to prevent accidental start-up.
- ⚠ WARNING:** Be sure there is adequate clearance for tool and operator hands.
- ⚠ CAUTION:** Do not use beyond the design intent.

Lockbolts

#1. Insert fastener through the work piece.



#2. Slide collar over fastener.



#3. Insert fastener into nose assembly.



#4. Press actuator to start cycle.

#5. Release actuator as soon as fastener breaks.

#6. Repeat steps 1-5.

Blind Fasteners

1. Insert fastener into the work piece.



2. Insert fastener into nose assembly.



3. Press actuator to start cycle.



4. Release actuator as soon as fastener breaks.

5. Repeat steps 1-4.

Images may not reflect actual tool or fastener

DAILY MAINTENANCE



- ⚠ WARNING:** Tool must be maintained in a safe working condition at all times and examined on a daily basis for damage or wear. Any repair should be done by qualified personnel trained on Gage Bilt procedures.
- ⚠ WARNING:** Excessive contact with hydraulic oil and lubricants should be avoided.
- ⚠ WARNING:** Maintenance personnel **MUST** read and understand all warnings and cautions.
- ⚠ WARNING:** Disconnect tool from its power source before performing maintenance, cleaning or when replacing worn or damaged components. Severe personal injury may occur if power source is not disconnected.
- ⚠ WARNING:** Read SDS documents for all applicable materials.

Note:

- Dispose of hydraulic oil in accordance with manufacture safety datasheet.
- All tool materials are recyclable except rubber o'rings, seals and wipers.

The performance of any tool depends upon good maintenance practices. Following these minimal requirements daily will extend the life of your tool.

- * Only use a clean dry air supply set at 90 (6.2 bar) -100 p.s.i. (6.9 bar) equipped with a filter-regulator to prevent wear.
- * Check tool and nose assembly for damage. (Replace/Repair if necessary). See Overhaul pg. 15-16 for tool repair.
- * Inspect hoses and couplings for wear, damage and leaks. (Replace/Repair if necessary).
- * Cycle the tool several times to assure there are no leaks during use.
- * Keep hydraulic system free of dirt.
- * Proper care by operators is necessary in maintaining full productivity and reducing downtime.
- * Keep nose assemblies, especially jaws, clean and free of chips and debris.

WEEKLY MAINTENANCE

- Keep the hydraulic system full (only use Dexron III or equivalent) and free of air by using the air bleeder assy (704153) (sold separately) on a weekly basis. or as needed. (See Filling and Bleeding procedure pgs. 12-13).

SEE TROUBLESHOOTING (PG. 14) AND OVERHAUL (PG. 15-16) FOR FURTHER GUIDANCE.

CLEANING AND LUBRICATING PROCEDURE

Daily cleaning and lubrication of nose assembly will greatly reduce downtime and increase life of components. Using sewing machine oil, or an equivalent cleaner/lubricant, follow instructions below.

CLEANING

Clean nose assy daily or as often as needed.

1. Dip into mineral spirits or similar solvent to clean jaws and wash away metal chips and debris. **DO NOT** allow jaws to come in contact with other solvents. **DO NOT** let jaws soak. Dry jaws immediately.
2. Disassemble nose assy and use a sharp "pick" to remove embedded particles from grooves of jaws.

LUBRICATING

Lubricate nose assy after each cleaning and as often as needed.

1. Disconnect tool vacuum line (if equipped).
2. Point nose assembly into oil as shown.
3. Cycle tool 8-10 times and wipe dry.

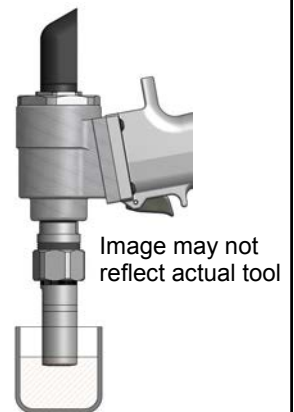

TORQUE SPECIFICATIONS

- Button Head Cap Screws (402479) = 35-40 inch lbs.
- Packing Plug (756218) = 45 foot lbs.
- Flexlock Nut (A-1089) = 17 foot lbs.
- End Cap (756116) = 50 foot lbs
- Button Head Cap Screws (402482)= 35-40 inch lbs. (*Do NOT over-tighten*)

FILLING PROCEDURE



- ⚠ WARNING:** Do not cycle tool without air bleeder assy (704153) (sold separately), or the screw and stat-o-seal, installed in tool head. Severe personal injury could result.
- ⚠ CAUTION:** Before filling handle assy, air piston assy should be all the way down.
- ⚠ CAUTION:** When forcing piston rod assy (756134) downward, with head cylinder (756300) removed, hydraulic oil will eject forcibly from handle assy (756229).
- ⚠ CAUTION:** When bleeding tool, ensure tubing is free from kinks or other obstructions.
- ⚠ CAUTION:** Use CAUTION when removing screws, air bleeder assy (704153) and fill bottle (745263) (sold separately). Hydraulic oil may be under pressure.

Note:

- Air Bleeder Assy (704153) (sold separately) is required.

IMPORTANT: Be sure to use thread sealant on all hydraulic fittings, Loctite® 545 or equivalent or a non-hardening Teflon® thread compound such as Slic-tite®. Tighten until fitting feels snug and then continue to tighten 1/2 to 1 full turn. **CAUTION:** Over tightening can easily distort the threads. DO NOT USE TEFLON® TAPE. **CAUTION:** Teflon® tape is an excellent thread sealer, however, if it is not properly applied, pieces of Teflon® may enter the hydraulic system and cause malfunction or damage.

Should it become necessary to completely refill the tool (as would be required after tool has been dismantled and reassembled), take the following steps:

1. Ensure the air piston assy (756121) is at the full bottom of its stroke, by pushing the piston rod assembly (756134) down until it stops.
2. Fill the power cylinder (756227) to top and oil passage to the bottom of counterbore, this should be done with gland-return (756126) removed. Use socket head cap screw (A-1201) to remove gland-return (756126).
3. Place gland-return (756126) into top of handle assy (756229) being careful not to tear o'rings when installing.
4. Push piston assy (756211) in head cylinder (756300) to its full forward position (See 'A' dimension fig. A pg. 13).
5. Install gasket (756148) and head cylinder (756300) onto top of handle assy (756229) being careful not to tear o'rings on head cylinder (756300) or gland-return (756126).
6. Install the four button head cap screws (402479) into the head cylinder (756300) and torque evenly to 40 inch lbs.

Note:

- Tool must be bled after filling. (See bleeding procedure pg. 13).

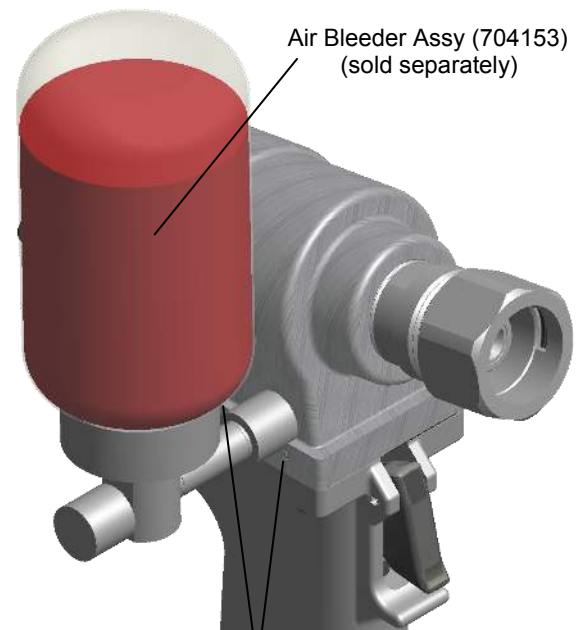
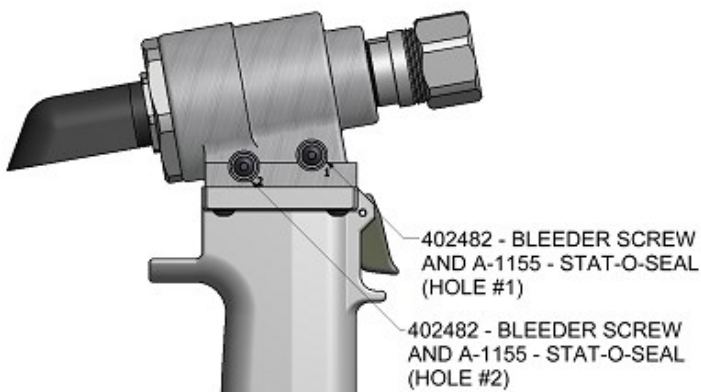

Bleeder hole #1 & #2 on head cylinder (756300)
Button head cap screw (402482) & stat-o-seal (A-1155)

Images may not reflect actual tool.

BLEEDING PROCEDURE:



- ⚠ WARNING:** Do not cycle tool without air bleeder assy (704153) (sold separately), or the screw and stat-o-seal, installed in tool head. Severe personal injury could result.
- ⚠ CAUTION:** Before filling handle assy, air piston assy should be all the way down.
- ⚠ CAUTION:** When forcing piston rod assy (756134) downward, with head cylinder (756300) removed, hydraulic oil will eject forcibly from handle assy (756229).
- ⚠ CAUTION:** When bleeding tool, ensure tubing is free from kinks or other obstructions.
- ⚠ CAUTION:** Use CAUTION when removing screws, air bleeder assy (704153) and fill bottle (745263) (solde separately). Hydraulic oil may be under pressure.

Note:

- Air Bleeder Assy (704153) (sold separately) is required.

1. Make sure air supply is disconnected. Make sure piston assy (756211) is in its full forward position (dimension 'A'), then remove front button head cap screw (402482) and stat-o-seal (A-1155) from bleeder hole #1 (See fig. B.) on head cylinder (756300).
2. Make sure the rear button head cap screw (402482) and stat-o-seal (A-1155) are installed in the head cylinder (756300) hole marked #2, and screw is torqued to (35-40) inch pounds. Do not over tighten.
3. Attach air bleeder assy (704153) (sold separately) to front of hole in head cylinder (756300) hole marked #1.
4. Set air supply to 40-50 psi (2.8-3.4 bar), connect air supply to the tool. Cycle tool ten times, while holding actuator (756142) down for five seconds, and releasing the actuator (756142) for five seconds.
5. Release the actuator (756142) and let the piston assy (756211) return to full forward position (Dim. A). Disconnect air supply and remove air bleeder assy (704153) (sold separately).
6. Install button head cap screw (402482) and stat-o-seal (A-1155) in head cylinder (756300) hole marked #1 and torque to 35-40 inch pounds. Do not over tighten.
7. Once both button head cap screws (402482) and stat-o-seals (A-1155) are installed in the head cylinder (756300) holes marked #1 and #2, and torqued to 35-40 inch pounds, (do not over tighten), connect the air supply 40-50 psi. (2.8-3.4 bar).
8. Hold the actuator (756142) down for 3 to 5 seconds and disconnect the air supply. The piston assy (756211) should be at (Dim. B).
9. Remove the rear button head cap screw (402482) and stat-o-seal (A-1155) from the head cylinder (756300) hole marked #2. Attach the air bleeder assy (704153) (sold separately) to the rear hold marked #2.
10. With the front button head cap screw (402482) and stat-o-seal (A-1155) installed and the air bleeder assy (704153) (sold separately) installed in hole marked #2, connect the air supply 40-50 psi. (2.8-3.4 bar) and cycle the tool ten times.
11. Hold the actuator (756142) down for 3 to 5 seconds and disconnect the air supply. The piston assy (756211) should be at (Dim. B).
12. Remove air bleeder assy (704153) (sold separately), install rear button head cap screw (402482) and stat-o-seal (A-1155) in head cylinder (756300) marked #2 and torque to 35-40 inch pounds. Do not over tighten.
13. Once both button head cap screws (402482) and stat-o-seals (A-1155) are installed in the head cylinder (756300) holes marked #1 and #2, and torqued to 35-40 inch pounds, (do not over tighten), connect the air supply 40-50 psi. (2.8-3.4 bar).
14. The piston assy (756211) should move full forward to (Dim. A). Cycle the tool ten to twenty times, checking the stroke (Dim. A) and (Dim. B). We recommend using dial calipers. If stroke checks ok the bleeding procedure is complete.
15. If Dim. A checks long and piston assy (756211) does not come completely full forward, disconnect air supply then remove both front and rear button head cap screws (402482) and stat-o-seals (A-1155) from holes marked #1 and #2 and push piston assy (756211) full forward until it stops (Dim. A) and repeat bleeding procedure beginning at step #8.
16. If Dim. B checks short, disconnect air supply, repeat steps 3-6.



Figure "A"

STROKE CHART

TOOL	STROKE LIMITER	STROKE LIMITER THICKNESS	STROKE	"A"	"B"
GB756	NONE	-	.96" 24.38mm	.147" 3.73mm	1.107" 28.12mm
	756152	.280	.68" 17.27mm	.147" 3.73mm	.827" 21.01mm
	756153	.210	.75" 19.05mm	.147" 3.73mm	.897" 22.78mm
	756155	.585	.375" 9.53mm	.147" 3.73mm	.522" 13.26mm

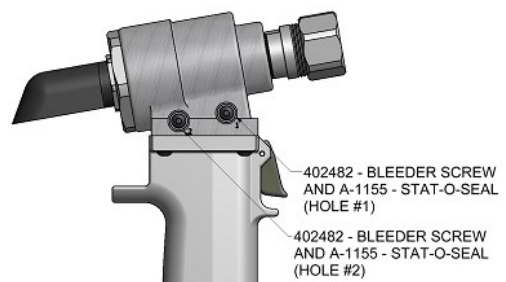

Figure "B"



Providing all maintenance conditions have been met, follow this systematic approach to diagnosis.

1. **MORE THAN ONE PULL IS REQUIRED TO BREAK FASTENER.**
 - a) Tool needs to be bled. (See filling and bleeding procedures pgs. 12-13).
 - b) Jaws are stripped or packed with chips. Clean or replace.
 - c) Incorrect nose assembly.

2. **SLOW OR PARTIAL OPERATION WHEN THE ACTUATOR (756142) IS DEPRESSED.**
 - a) Back-up Ring (401119) and O'Rings (403815) on the piston assy (756211) could be worn or damaged. Replace.
 - b) Back-up Rings (401086) and O'Ring (403770) on the piston rod assy (756134) could be worn or damaged. Replace.

3. **NO OPERATION WHEN ACTUATOR (756142) IS DEPRESSED.**
 - a) Tool seized due to mechanical failure or damaged parts.

4. **OIL LEAKAGE.**
 - a) **DO NOT** OPERATE WITH OIL LEAKING FROM TOOL. HIGH PRESSURE OIL MAY CAUSE SEVERE PERSONAL INJURY.
 - b) Any oil leaking externally should be traced to its source. An o'ring or seal that leaks should be replaced.

5. **AIR BYPASS FROM THROTTLE VALVE HOUSING.**
 - a) If the spring (50607) breaks, air will flow freely through the muffler (756145). Replace.
 - b) Check o'rings on throttle valve (756140). If worn or damaged, replace.

6. **FASTENER STEM JAMMED IN NOSE ASSEMBLY.**
 - a) Nose assembly components require service. **DISCONNECT AIR FROM TOOL**, remove the nose from the tool and disassemble. Replace worn or broken parts. Clean the surface the jaws ride on.
 - b) Stems lodged side by side in the follower. Disassemble, remove stems, and reassemble.
 - c) Incorrect follower.



- ⚠ WARNING:** Only qualified and trained personnel should perform overhaul.
- ⚠ WARNING:** Personnel must read and understand all warnings and cautions.
- ⚠ WARNING:** Tool must be maintained in a safe working condition at all times and examined on a daily basis for damage or wear. Any repair should be done by qualified personnel trained on Gage Bilt procedures.
- ⚠ WARNING:** Disconnect tool from its power source before performing overhaul. Severe personal injury may occur if power source is not disconnected.
- ⚠ WARNING:** Excessive contact with hydraulic oil and lubricants should be avoided (See SDS documents for all applicable materials).
- ⚠ WARNING:** When operating, repairing or overhauling tool, wear approved eye protection. Do not look in front of tool or rear of tool when installing fastener.
- ⚠ WARNING:** Ensure air hose is securely connected to avoid possible hose whipping (Air Actuated Tools only).
- ⚠ WARNING:** Depress actuator (756142) and disconnect from air, with the piston in the rear position, before overhaul. Severe personal injury may occur if air hose is not disconnected. **USE CAUTION** when forcing piston rod assy downward with head cylinder removed. Hydraulic oil will eject forcibly from handle assy.

Note:

- Dispose of hydraulic oil in accordance with manufacture safety datasheet.
- All tool materials are recyclable except rubber o’rings, seals and wipers.

Perform overhaul in a clean, well lit area using care not to scratch or nick any smooth surface that comes in contact with an o’ring. Use of Lubriplate® (Gage Bilt part no. 402723) or other lubricant is recommended during reassembly to prevent tearing or distorting of o’rings.

The disassembly and re-assembly procedure can be accomplished by utilizing the following instructions and parts lists on pgs. 15-17. Use extreme care during disassembly and re-assembly not to mar or nick any smooth surface that comes in contact with seals. Before installing seals, always apply a good lubricant, such as Lubriplate®, to the surfaces. It is recommended that tool kit (GB756TK) be used to facilitate overhaul. A complete overhaul can be achieved by the use of Service Kit (756004) which contains a complete set of o’rings, back-up rings, screws, washers and gasket.

Clean parts in mineral spirits or other o’ring compatible solvent being sure to clean o’ring grooves. Inspect components for scoring, excessive wear or damage.

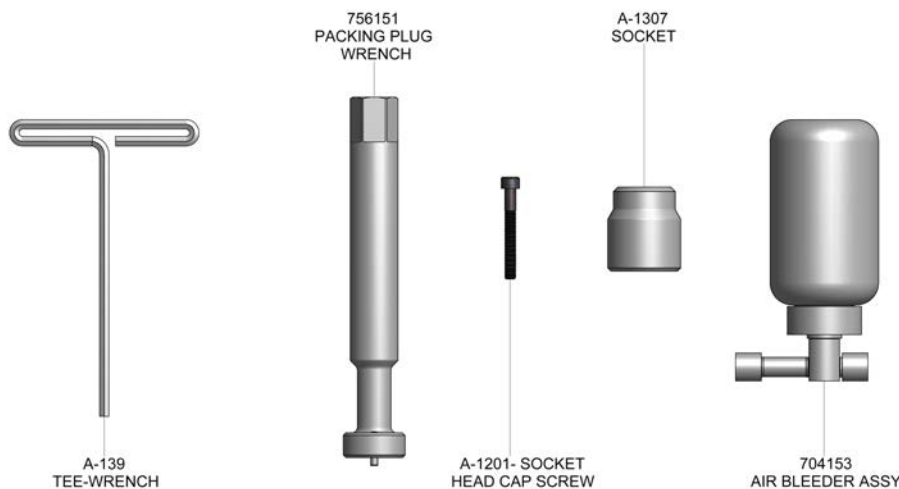

GB756TK Service Tool Kit Includes:

Part No.	Description
A-139	Tee Wrench
756151	Packing Plug Wrench
A-1201	Socket Head Cap Screw
A-1307	DR 6PT Socket
704153	Air Bleeder Assy

TOOL DISPOSAL

1. When tool life is met, drain hydraulic oil from tool and dispose of the hydraulic oil in accordance with all environmental regulations applicable to your area.
2. Disassemble tool and remove all rubber o’rings, seals, wipers and hydraulic hoses. All tool materials are recyclable except rubber o’rings, seals, wipers and hydraulic hoses. Dispose of rubber materials in accordance with all environmental regulations applicable in your area.



⚠ WARNING: Disconnect tool from its air source before disassembly.

HEAD

1. Remove nose assembly and adapter from tool before attempting disassembly of head cylinder (756300).
2. Remove deflector (756120) and end cap (756116).
3. Push against threaded end of piston assembly (756211) to slide it out of head cylinder (756300). Be careful not to damage threads or cause burrs on polished piston rod assy surface.

The re-assembly sequence is the opposite of disassembly. (See Filling and Bleeding procedures pgs. 12-13). Apply Loctite® #242 and torque the four button-head cap screws (402479) uniformly to 35-40 inch lbs. to prevent leakage around the gasket (756148).

HANDLE

To inspect air cylinder bore, remove base plate (756144), spring (50607), muffler (756145), o’ring (400777), gasket (756149), retaining ring (A-1086) and base cover (756124). Any further disassembly will require removal of the head cylinder (756300) first.

For complete disassembly.

1. Removing base plate (756144), muffler (756145), o’ring (400777), gasket (756149), retaining ring (A-1086) and base cover (756124).
2. Holding tool upright, remove four button-head cap screws (402479). Lift head cylinder (756300), gasket (756148) and gland-return (756126) from handle assy (756229).
3. Use socket head cap screw (A-1201) to remove gland-return (756126).
4. Empty all hydraulic oil into an approved container and dispose of in accordance with all environmental regulations applicable to your area.
5. Place tee wrench (A-139) down into top of power cylinder into hex on piston rod assy (756134). While holding tee wrench (A-139), put a 9/16 socket wrench on flexlock nut (A-1089) and loosen piston rod cap “not shown” from piston rod.
6. Using vice grips, grab flexlock nut (A-1089) and remove air piston assy (756121) from bottom of handle assy (756229).
7. After removal of air piston assy (756121), use packing plug wrench (756151) and remove packing plug (756218).
8. Stand tool upright and carefully push on top of power cylinder (756227) to eject from bottom of handle assy (756229), not letting it drop and nick large cylinder bore handle. Remove piston rod cap from inside of power cylinder (756227).

To reassemble the handle assy (756229).

1. Reverse the above procedure, being certain that all o’rings are properly lubricated. After installing the power cylinder (756227), install the packing plug (756218) and torque to 45 foot lbs.
2. Push piston rod assy (756134) thru the packing plug (756218) with the air piston assy (756121) attached. Be sure when attaching air piston assy (756121) to piston rod assy (756134) that the washer i.d. with the chamfer on one side is face up. (See fig. “C”).
3. Install piston rod cap back into the power cylinder (756227) and tighten securely to the piston rod using tee wrench and 9/16 socket wrench.
4. Re-install the spring (50607), muffler (756145), o’ring (400777), gasket (756149) and base cover (756124), retaining ring (A-1086) and base plate (756144).
5. With piston rod assy (756134) in the down position, fill oil passages on top of handle assy (756229) with automatic transmission oil. Dexron® III, or equivalent. See Filling and Bleeding instructions for more information.
6. Replace gasket (756148) and o’ring (S829), just prior to replacing head cylinder (756300). Torque all screws to manual specifications. (See Filling & Bleeding procedures pgs. 12-13) & (See torque specs. pg. 11).

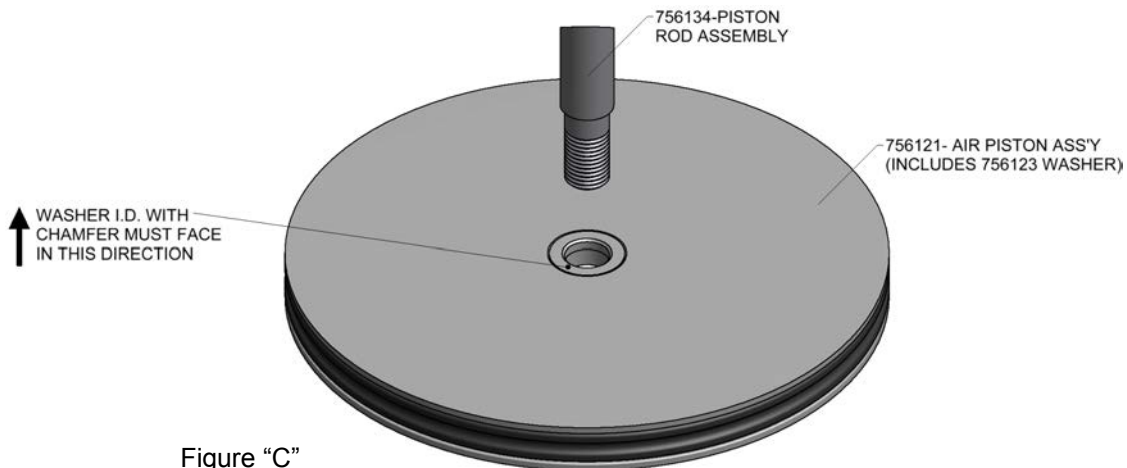
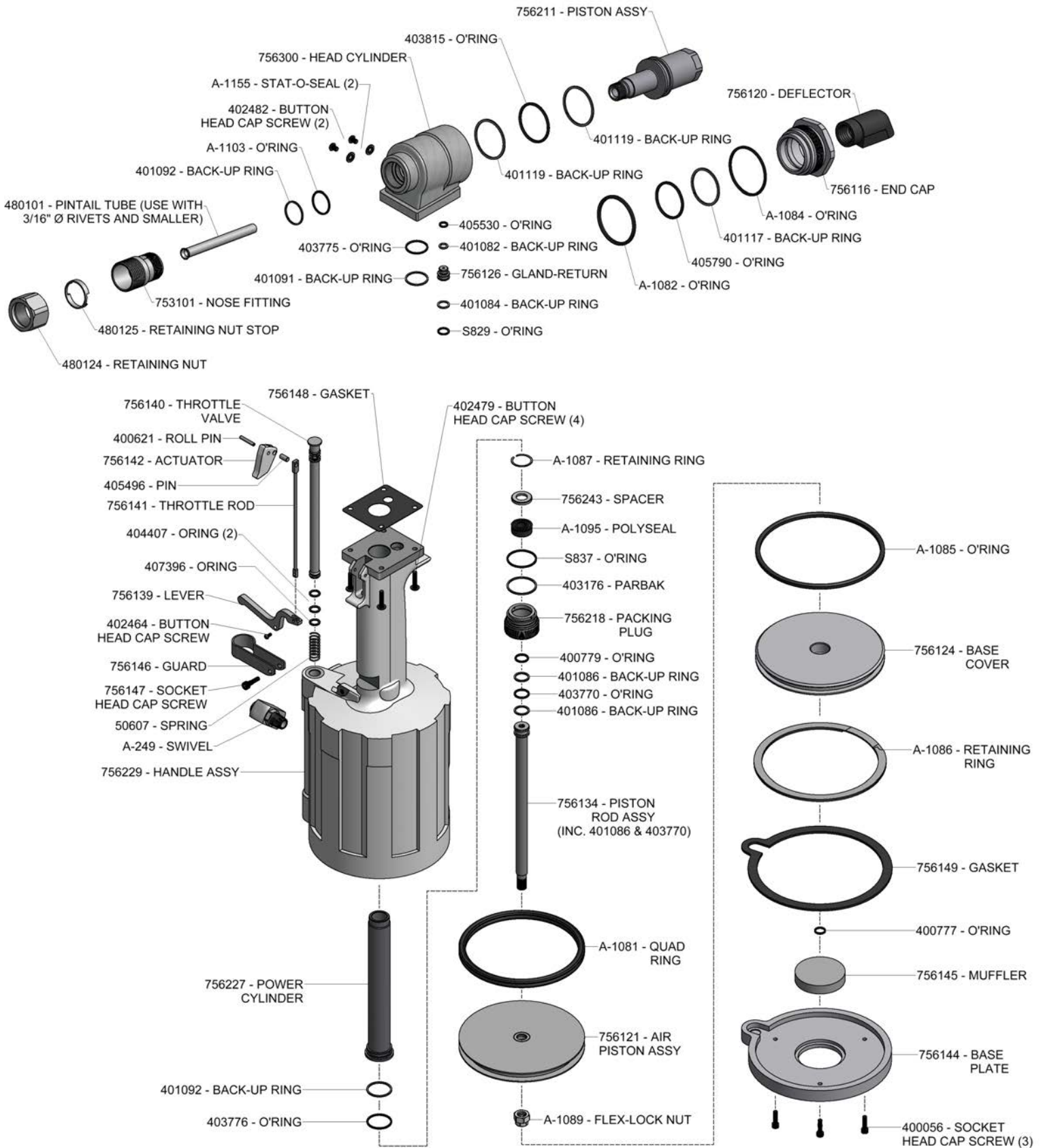

Figure “C”

PARTS LIST





FIRST AID MEASURES

Eye: No specific first aid measures are required. As a precaution, remove contact lenses, if worn, and flush eyes with water.
Skin: No specific first aid measures are required. As a precaution, remove clothing and shoes if contaminated. To remove the material from skin, use soap and water. Discard contaminated clothing and shoes or thoroughly clean before reuse.
Ingestion: No specific first aid measures are required. Do not induce vomiting. As a precaution, get medical advice.
Inhalation: No specific first aid measures are required. If exposed to excessive levels of material in the air, move the exposed person to fresh air. Get medical attention if coughing or respiratory discomfort occurs.
Note to Physicians: In an accident involving high-pressure equipment, this product may be injected under the skin. Such an accident may result in a small, sometimes bloodless, puncture wound. However, because of its driving force, material injected into a fingertip can be deposited into the palm of the hand. Within 24 hours, there is usually a great deal of swelling, discoloration, and intense throbbing pain. Immediate treatment at a surgical emergency center is recommended.

FIRE

Leaks/ruptures in high pressure system using materials of this type can create a fire hazard when in the vicinity of ignition sources (eg. open flame, pilot lights, sparks, or electric arcs).

FLAMMABLE PROPERTIES:

Flashpoint: (Cleveland Open Cup) 178 °C (352 °F) Minimum

EXTINGUISHING MEDIA: Use water fog, foam, dry chemical or carbon dioxide (CO2) to extinguish flames.

PROTECTION OF FIRE FIGHTERS:

Fire Fighting Instructions: This material will burn although it is not easily ignited. See Section 7 for proper handling and storage. For fires involving this material, do not enter any enclosed or confined fire space without proper protective equipment, including self-contained breathing apparatus.

Combustion Products: Highly dependent on combustion conditions. A complex mixture of airborne solids, liquids, and gases including carbon monoxide, carbon dioxide, and unidentified organic compounds will be evolved when this material undergoes combustion.

ACCIDENTAL RELEASE MEASURES

Protective Measures: Eliminate all sources of ignition in vicinity of spilled material.

Spill Management: Stop the source of the release if you can do it without risk. Contain release to prevent further contamination of soil, surface water or groundwater. Clean up spill as soon as possible. Use appropriate techniques such as applying non-combustible absorbent materials or pumping. Where feasible and appropriate, remove contaminated soil. Place contaminated materials in disposable containers and dispose of in a manner consistent with applicable regulations.

ECOLOGICAL INFORMATION

Waste disposal: In accordance with all environmental regulations applicable to your area.

Spillage: Prevent entry into drains, sewers and water course. Soak up with diatomaceous earth or other inert material. Store in appropriate container for disposal.

Ecotoxicity: This material is expected to be harmful to aquatic organisms and may cause long-term adverse effects in the aquatic environment. The ecotoxicity hazard is based on an evaluation of data for the components or a similar material.

HANDLING

Precautionary Measures: DO NOT USE IN HIGH PRESSURE SYSTEMS in the vicinity of flames, sparks and hot surfaces. Use only in well ventilated areas. Keep container closed. Keep out of the reach of children.

General Handling Information: Avoid contaminating soil or releasing this material into sewage and drainage systems and bodies of water.

Static Hazard: Electrostatic charge may accumulate and create a hazardous condition when handling this material. To minimize this hazard, bonding and grounding may be necessary but may not, by themselves, be sufficient. Review all operations which have the potential of generating and accumulating an electrostatic charge and/or a flammable atmosphere (including tank and container filling, splash filling, tank cleaning, sampling, gauging, switch loading, filtering, mixing, agitation, and vacuum truck operations) and use appropriate mitigating procedures.

DISPOSAL CONSIDERATIONS

Use material for its intended purpose or recycle if possible. Oil collection services are available for used oil recycling or disposal. Place contaminated materials in containers and dispose of in a manner consistent with applicable regulations.

ACCESSORIES



NOSE ASSEMBLY SELECTION CHART

STRAIGHT
(Sold Separately)

RIGHT ANGLE
(Sold Separately)

OFFSET
(Sold Separately)



FASTENER	DIA.	STRAIGHT	**RIGHT ANGLE	*OFFSET		
ASP® 2 ASP & ASP PF ASP FF & ASP F ASP-LC and MAF	13/64 17/64 21/64	ASP06-745C-23 ASP08-745B-23 ASP10-755-23	ASP06-745C-48 ASP08-745B-48 ASP10-755-48	***ASP06-751B-54RA	ASP06-204D-27OS ASP08-204D-27OS ASP10-204D-27OS	ASP06-204D-37OS ASP08-204D-37OS ASP10-204D-37OS
BOM® AVBOLT®	1/4 5/16	BOM08-755A-23 BOM10-756-26				
COMMERCIAL LOCKBOLTS C&L® AVDELOK®	3/16 1/4 5/16 3/8	NAS06-2581-12 NAS06-2581-23 NAS08-2581-12 NAS08-2581-23 LB10-745C-26 LB12-756-26	NAS06-2581-48 NAS08-2581-48 NAS10-2581-48 NAS12-756-48		NAS06-204C-25OS NAS06-204C-34OS NAS08-204C-25OS NAS08-205A-31 NAS10-205D-31 NAS12-205A-31	NAS06-204D-30OS NAS08-204D-30OS NAS08-204C-34OS
CONTAINER BOLT	3/8	HT12-756-23				
FLOOR BOLT	5/16	FT10-353A-28				
LGP® LOCKBOLT	5/32 3/16	LGP05-2581-12 LGP05-2581-48 LGP06-2581-12 LGP06-2581-48	LGP05-2581-23 LGP06-2581-23		LGP05-204C-25OS LGP05-204C-34OS LGP06-204C-25OS LGP06-204C-34OS	LGP05-204C-30OS LGP06-204D-30OS
LGPL2SC-V BACB30VM LGPL18SC-V BACB30XT LGPL4SC-V ABS0548 LGPL2SP-V BACB30VN LGPL4SP-V ASNA2392 LGPL8SC-V BACB30WD LGPL9SC-V BACB30WB LGPL9SP-V BACB30VY BACB31N BACB31P	7/32 1/4 5/16 3/8	LGP07-2581-12 LGP07-755-48 LGP08-2581-12 LGP08-2581-48 LGP10-2581-12 LGP10-2581-48 LGP12-745B-12 LGP12-756-48	LGP07-755-23 LGP08-2581-23		LGP07-204C-25OS LGP07-204C-34OS LGP08-204C-25OS LGP08-204C-34OS LGP10-205D-31 LGP12-205A-31	LGP07-204C-30OS LGP08-204D-30OS LGP08-205A-31
MLGP® (MILLIMETER) LOCKBOLT	4mm 5mm 6mm 8mm 10mm	MLGP4-2581-12 MLGP4-2581-23 MLGP5-2581-12 MLGP5-2581-23 MLGP6-2581-12 MLGP6-2581-23 MLGP8-2581-12 MLGP8-2581-23 MLGP10-2581-23	MLGP4-2581-48 MLGP5-2581-48 MLGP6-2581-48 MLGP8-2581-48 MLGP10-2581-48		MLGP4-204C-25OS MLGP4-204C-34OS MLGP5-204C-25OS MLGP5-204C-34OS MLGP6-204C-25OS MLGP6-204C-34OS MLGP8-204C-25OS MLGP8-204C-34OS	MLGP4-204C-30OS MLGP5-204D-30OS MLGP6-204D-30OS MLGP8-204C-30OS MLGP8-205A-31
NAS and GP® SHEAR/TENSION LOCKBOLTS	5/32 3/16 1/4 5/16 3/8	NASS05-2581-12 NASS05-2581-23 NASS05-2581-48 NAS06-2581-12 NAS06-2581-48 NAS08-2581-12 NAS08-2581-48 NAS10-2581-12 NAS10-2581-48 NAS12-745B-12 NAS12-756-48	NAST05-2581-12 NAST05-2581-23 NAST05-2581-48 NAS06-2581-23		NASS05-204C-25O NASS05-204C-30O NASS05-204C-34O NAS06-204C-25OS NAS06-204C-34OS NAS08-204C-25 NAS08-204C-34 NAS10-205D-31 NAS12-205A-31	NAST05-204C-20O NAST05-204C-30O NAST05-204C-34O NAS06-204D-30OS NAS08-204D-30OS NAS08-205A-31
MGP® (MILLIMETER) LOCKBOLT	4mm 5mm 6mm 8mm 10mm	MGP4-2581-23 MGP5-2581-23 MGP6-2581-23 MGP8-2581-23 MGP10-2581-23	MGP4-2581-48 MGP5-2581-48 MGP6-2581-48 MGP8-2581-48 MGP10-2581-48		MGP4-204C-25OS MGP4-204C-34OS MGP5-204C-25OS MGP5-204C-34OS MGP6-204C-25OS MGP6-204C-34OS	MGP4-204C-30OS MGP5-204D-30OS MGP6-204D-30OS
MULTI-GRIP LOCKBOLT MAGNA-GRIP® and MAXLOK®	3/16 1/4 5/16 3/8	MG06-745-24 MG08-745-24 MG10-756-28 MG12-756-28	MG06-745-48 MG08-745-48			
MULTI-GRIP STRUCTURAL BLIND RIVET	1/4 5/16 3/8	**MGL08-752A-21 MGL10-353-28 MGL12-353C-28				
OVERSIZE STRUCTURAL RIVET	1/4 5/16 3/8	OS08-353A-48 OS10-756-26 OS12-756A-26	OS10-756-48 OS12-756A-48			
BLIND BOLT (SINGLE ACTION) WITH OR W/O DRIVE WASHER	5/32 3/16 1/4 5/16 3/8	SB05-745C-23 SB06-745B-23 SB08-755-23 SB10-756-28 SB12-756-28	SB05-745C-48 SB06-745B-48 SB08-755-48	***SB05-751C-54RA ***SB06-751B-54RA ***SB08-713A-58RA	SB05-204D-27OS SB06-204D-27OS SB08-204D-27OS SB08-205A-35 SB10-205A-35 SB12-205A-35	SB05-204D-37OS SB06-204D-37OS SB08-204D-37OS
BLIND BOLT (SINGLE ACTION) WITH DRIVE WASHER	5/32 3/16 1/4 5/16 3/8	UBB05-745C-23 UBB06-745B-23 UBB08-755-23 UBB10-756-28 UBB12-756-28	UBB05-745C-48 UBB06-745B-48 UBB08-755-48	***UBB05-751C-54RA ***UBB06-751B-54RA ***UBB08-713A-58RA	UBB05-204D-27OS UBB06-204D-27OS UBB08-204D-27OS UBB08-205B-35 UBB10-205B-35 UBB12-205A-35	UBB05-204D-37OS UBB06-204D-37OS UBB08-204D-37OS

ASP®, BOM®, LGP®, C&L®, GP®, MLGP®, MGP®, and MAGNA-GRIP® ARE REGISTERED TRADEMARKS OF ARCONIC INC. AVBOLT®, AVDELOK®, and MAXLOK® ARE REGISTERED TRADEMARKS OF AVDEL UK LIMITED. MAXI-BOLT® IS A REGISTERED TRADEMARK OF CHERRY AEROSPACE FASTENERS.

GAGE BILT CERTIFIES THE GB756 WILL INSTALL THE ABOVE FASTENERS
See www.gagebilt.com/nose_assemblies.php for nose assembly information (data sheets)

*ALL OFFSET 204 SERIES NOSES REQUIRE 353204 ADAPTER WITH 756152 STROKE LIMITER.
*ALL OFFSET 205 SERIES NOSES REQUIRE 353205 ADAPTER WITH 756153 STROKE LIMITER.
**NOSE REQUIRES 745751 ADAPTER
***-54RA RIGHT ANGLE SERIES NOSES REQUIRE 745751 ADAPTER WITH 756155 STROKE LIMITER.
****-58RA RIGHT ANGLE NOSES REQUIRE 745751 WITH 756152 STROKE LIMITER.

NOTE: THE LAST 2 DIGITS OF THE NOSE ASSEMBLY REPRESENTS THE LENGTH THE NOSE EXTENDS FROM THE TOOL. I.E. -20 = 2.0 INCHES

Rev. 3/18



**Adapter Assy
#353204**

Adapts 204 series nose assemblies to GB756
installation tool w/ 756152 stroke limiter.
(Sold Separately)

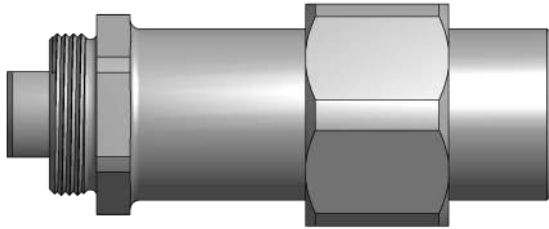

Other adapters available. Contact Gage Bilt for
more information.

**Adapter Assy
#353205**

Adapts 205 series nose assemblies to GB756
installation tool w/ 756153 stroke limiter.
(Sold Separately)

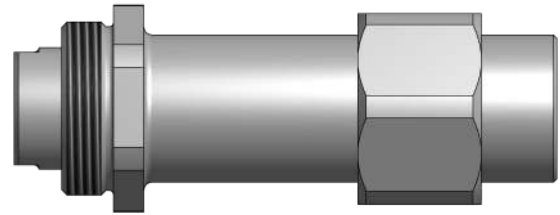

Other adapters available. Contact Gage Bilt for
more information.

**Adapter Assy
#745751**

Adapts -54 & -58 RA series nose assemblies to
GB756 installation tool w/ 756155 stroke limiter.
(Sold Separately)

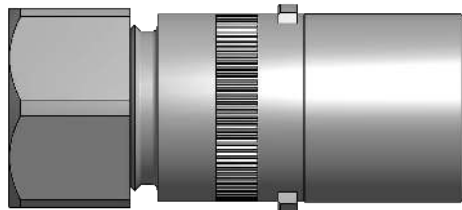

Other adapters available. Contact Gage Bilt for
more information.



Stroke Limiter

#756152

Required with all offset 204 & -58 RA series nose
assy's when used on GB756 tool. See *Chart pg. 19*.
(Sold Separately)



Stroke Limiter

#756153

Required with all offset 205 series nose assy's
when used on GB756 tool. See *Chart pg. 19*.
(Sold Separately)



Stroke Limiter

#756155

Required with all -54 RA series nose assy's
when used on GB756 tool. See *Chart pg. 19*.
(Sold Separately)



Grip Gage #GB105093

For NAS LOCKBOLTS and blind fasteners
(Sold Separately)



Catcher Bag-Stem

#756610
(Sold Separately)



Air Bleeder Assy

#704153
(Sold Separately)



Gage Bilt also supplies pin & collar swage inspection gages to certify swage installation.
(Sold Separately)

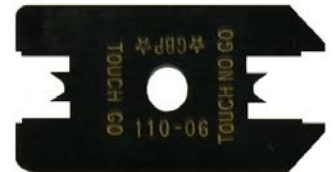



This page intentionally left blank

RIVETER KITS AVAILABLE

(Sold Separately)



Gage Bilt offers a wide selection of standard and custom kits tailored to your needs.
Contact us for more information.



DEXRON® IS A REGISTERED TRADEMARK OF GENERAL MOTORS CORPORATION. LUBRIPLATE® IS A REGISTERED TRADEMARK OF FISKE BROTHERS REFINING. LOCTITE® IS A REGISTERED TRADEMARK OF HENKEL CORPORATION. TEFLON® IS REGISTERED TRADEMARK OF E.I. DUPONT DE NEMOURS & CO. SLIC-TITE® IS A REGISTERED TRADEMARK LA-CO INDUSTRIES.

GB756 S/N: 1226 AND ABOVE
PLEASE CONTACT GAGE BILT FOR ALL OTHER SERIAL NUMBERS.