

ORIGINAL INSTRUCTIONS

GB784 INSTALLATION TOOL



GAGE BILT
 **MADE in USA**

 **INNOVATIVETOOLING**
On the leading edge of Aircraft Tooling
 800-832-7009
 sales@innovativetooling.com
 innovativetooling.com

TABLE OF CONTENTS



	<u>Page</u>
EU Conformity and Warranty	3
Description and Technical Specifications.....	4
Description of Functions	5
Warnings.....	6
Principle of Operation	7
How to set-up the GB784.....	8
How to use the GB784	9
Maintenance.....	10
Filling and Bleeding	11
Troubleshooting	12
Overhaul.....	13-16
Parts Lists	17
DEXRON® III Oil Safety Data (SDS)	18
Setting the Shift Point.....	19
Shift Piston Check.....	20
Nose Assembly Selection Chart	21
Accessories	22 & 24

DECLARATION OF CONFORMITY

MANUFACTURER: Gage Bilt Inc. 44766 Centre Ct. Clinton Twp. Michigan U.S.A. +1(586-226-1500)

WE DECLARE THAT THE EQUIPMENT SPECIFIED HEREIN CONFORMS TO THE FOLLOWING DIRECTIVES AND STANDARDS

Machinery Directive 2006/42/EC

EN12100-1 & EN12100-2

EN792-1:2000+A1

EU REPRESENTATIVE: Edgar Hausmann GmbH Förster-Busch-Str. 10 D-34346 Hann. Münden Germany

EQUIPMENT DESCRIPTION: GB784 FASTENER INSTALLATION TOOL

This product specified above conforms to the above directives and standards.

SIGNATURE:



NAME: BRIAN LEIGH
PRODUCT MANAGER
CLINTON TWP., MI U.S.A.
MAY 2010
+1(586) 226-1500

WARRANTY

Seller warrants that all goods covered by this catalog will conform to applicable specifications and will replace or repair, EXW our plant, any goods providing defective from faulty workmanship, or material, for 1 year from date of shipment.

Said warranty to remain in effect if, and only if, such goods are used in accordance with all instructions as to maintenance, operation and use, set forth in manuals and instruction sheets furnished by seller.

Sellers obligation under this warranty shall be limited to the repair or rework of the goods supplied or replacement thereof, at Seller's option, and in no case is to exceed the invoice value of said goods. Under no circumstances will the seller be liable for incidental or consequential damages or for damages incurred by the buyer or subsequent user in repairing or replacing defective goods or if the goods covered by this warranty are reworked or subjected to any type of additional processing.

This warranty is void if Seller is not notified in writing of any rejections or defects within 1 year after the receipt of the material by the customer.

THIS WARRANTY IS MADE IN LIEU OF ALL OTHER WARRANTIES EXPRESSED OR IMPLIED, INCLUDING MERCHANTABILITY.

DESCRIPTION



⚠ WARNING: Any other use is forbidden.

The GB784 is a pneumatic-hydraulic hydro-shift tool designed specifically for the efficient installation of the 2000 series CHERRYLOCK®, NAS1398, NAS1399, NAS1738 and NAS1739 double action blind fasteners. The GB784 weighs only 8 lbs. (3.62 kg) and can be operated in any position. It has a .875" (22.2 mm) rivet setting stroke and a rated pull load of 2,650 lbs. (11.78 kN) with 90 psi (6.2 bar) of air pressure at the air inlet.

The GB784 installation tool operates on 90 to 100 psi (6.2-6.9 bar) of air pressure with 90 psi (6.2 bar) providing the maximum efficiency. At 90 psi (6.2 bar) of air pressure, the GB784 does not exceed 81.5 dB(A) and consumes .30 SCF/cycle (8.50 L/cycle).

The air inlet is provided with 1/4-18 female pipe thread to accept the users air hose fitting.

NOSE ASSEMBLIES ARE NOT FURNISHED WITH TOOL AND MUST BE ORDERED SEPARATELY. (See nose assembly selection chart pg. 21 for nose assembly recommendations.)

ENVIRONMENTAL USE

⚠ WARNING: Do not operate in an explosive atmosphere.

The GB784 can be operated between 0°F — 118°F (-17.8°C / 47.8°C)

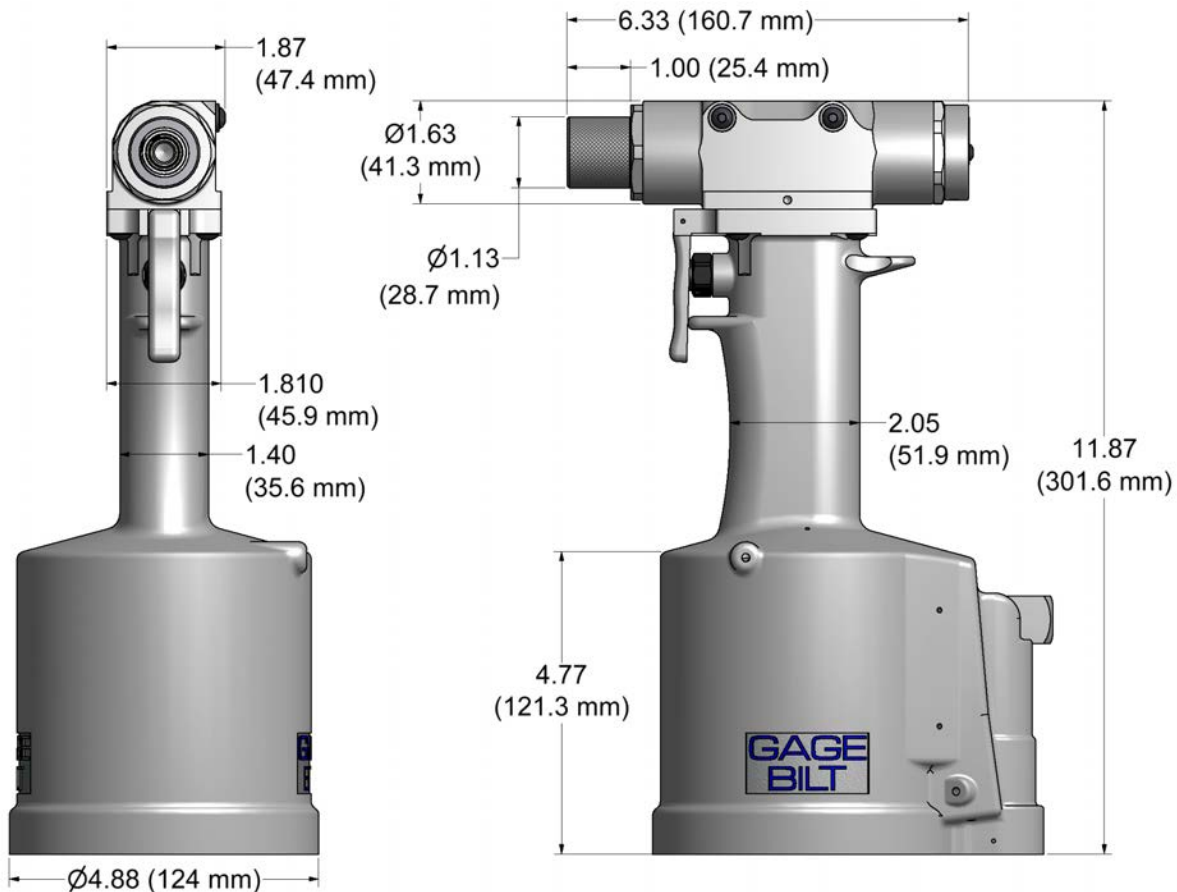

SPECIFICATIONS

Hand Held Weight	- 8.00 lbs. (3.62 kg)
Air pressure req'd	- 90-100 p.s.i.
Air consumption	- .30 SCF/cycle (8.50 L/cycle)
Hydraulic Oil	- Automatic Transmission Oil, Dexron III, or equivalent.
Setting stroke	- .875" (22.2 mm)
Rated pull load	- 2,650 lbs. (11.78 kN)
Noise level	- 81.5 dB(A)
Vibration	- Tested— No hazards found.

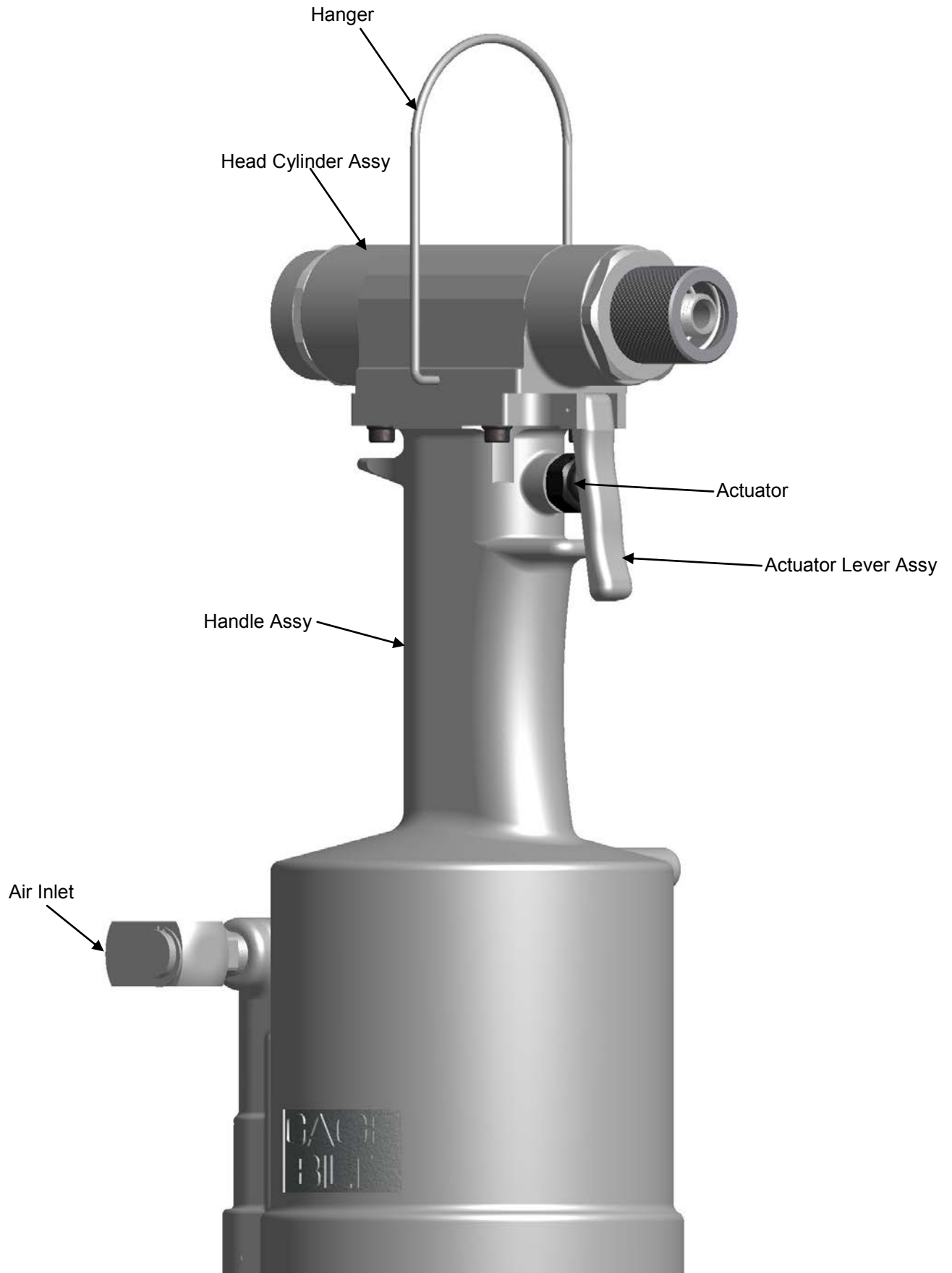

Image may not reflect actual tool



TERMS AND SYMBOLS



- Product complies with requirements



- Hearing protection and eye protection



- Read manual prior to using equipment



- Wear safety boots



WARNINGS - Must be understood to avoid severe personal injury.



CAUTIONS - show conditions that will damage equipment and/or structure.

Notes - are reminders of required procedures.

OPERATING HAZARDS:

1. Use of tool can expose the operator's hands to hazards, including crushing, impacts, cuts, abrasions and heat. Wear suitable gloves to protect hands.
2. Operators and maintenance personnel shall be physically able to handle the bulk, weight and power of the tool.
3. Hold the tool correctly; be ready to counteract normal or sudden movements and have both hands available.
4. Maintain a balanced body position and secure footing.
5. Release the start-and-stop device in the case of interruption of energy supply.
6. Use only lubricants recommended by the manufacturer.
7. Avoid unsuitable postures as it is likely for these positions not to allow counteracting of normal or unexpected movement of the tool.
8. If the tool is fixed to a suspension device, make sure that fixation is secure.
9. Beware of the risk of crushing or pinching if nose equipment is not fitted.
10. Due to the tool weight, it is recommended safety shoes be worn during operation.
11. It is recommended tool be operated not more than 50 out of every 60 minutes, where prolonged use is expected.

REPETITIVE MOTIONS HAZARDS:

1. When using the tool, the operator can experience discomfort in the hands, arms, shoulders, neck or other parts of the body.
2. While using the tool, the operator should adopt a comfortable posture while maintaining a secure footing and avoiding awkward or off balanced postures. The operator should change posture during extended tasks; this can help avoid discomfort and fatigue.
3. If the operator experiences symptoms such as persistent or recurring discomfort, pain, throbbing, aching, tingling, numbness, numbness, sensations or stiffness, these warning signs should not be ignored. The operator should tell the employer and consult a qualified health professional.

GENERAL SAFETY RULES:

1. For multiple hazards, read and understand the safety instructions before installing, operating, repairing, maintaining, changing accessories on, or working near the assembly power tool for non-threaded mechanical fasteners.
2. Only qualified and trained operators should install, adjust or use the assembly power tool for non threaded mechanical fasteners.
3. Do not modify this assembly power tool for non-threaded mechanical fasteners. Modifications can reduce effectiveness of safety measures and increase the risks to the operator.
4. Do not discard safety instructions; give them to the operator.
5. Do not use assembly power tool for non-threaded mechanical fasteners if it has been damaged.
6. Tools shall be inspected periodically to verify all ratings and markings required are legible. The employer/user shall contact the manufacturer to obtain replacement marking labels when necessary.
7. Air under pressure can cause severe injury.
8. Always shut off air supply, drain hose of air pressure and disconnect tool from air supply when not in use, before changing accessories or when making repairs.
9. Never direct air at yourself or anyone else.
10. Whipping hoses can cause severe injury. Always check for damage or loose hoses and fittings.
11. Cold air shall be directed away from hands.
12. Whenever universal twist couplings (claw couplings) are used, lock pins shall be installed and whipcheck safety cables shall be used to safeguard against possible hose-to-tool or hose-to-hose connection failure.
13. Do not exceed the maximum air pressure stated on the tool or manual.
14. Never carry an air tool by the hose.

ADDITIONAL SAFETY RULES FOR PNEUDRAULIC POWER TOOLS:

1. Air under pressure can cause severe injury.
2. Always shut off air supply, drain hose of air pressure and disconnect tool from air supply when not in use, before changing accessories or when making repairs.
3. Never direct air at yourself or anyone else.
4. Whipping hoses can cause severe injury. Always check for damage or loose hoses and fittings.
5. Cold air shall be directed away from hands.
6. Whenever universal twist couplings (claw couplings) are used, lock pins shall be installed and whipcheck safety cables shall be used to safeguard against possible hose-to-tool or hose-to-hose connection failure.
7. Do not exceed the maximum air pressure stated on the tool or manual.
8. Never carry an air tool by the hose.

PROJECTILE HAZARDS:

1. Disconnect the tool from the energy source when changing inserted tools/nose assemblies or accessories.
2. Be aware that failure of the workpiece or accessories, or even the inserted tool/nose assembly itself can generate high-velocity projectiles.
3. Always wear impact resistant eye protection during operation of the tool. The grade of protection required should be assessed for each use.
4. The risk to others should also be assessed at this time.
5. Ensure that the workpiece is securely fixed.
6. Check that the means of protection from ejection of fastener and/or stem is in place and operative (such as the deflector).
7. Forcible ejection of the mandrel from the front of the nose assembly is possible.

ACCESSORY HAZARDS:

1. Disconnect tool from energy supply before changing the nose assembly or accessory.
2. Use only sizes and types of accessories recommended by the manufacturer. Do not use other types or sizes of accessories.

WORKPLACE HAZARDS:

1. Slips, trips and falls are major causes of workplace injury. Be aware of slippery surfaces caused by use of tool and also of trip hazards caused by the air line or hydraulic hose.
2. Proceed with care in unfamiliar surroundings. There could be hidden hazards, such as electricity or other utility lines.
3. The tool is not intended for use in potentially explosive atmospheres and is not insulated against contact with electrical power.
4. Ensure that there are no electrical cables, gas pipes, etc., which can cause a hazard if damaged by the tool.

NOISE HAZARDS:

1. Exposure to high noise levels can cause permanent, disabling hearing loss and other problems, such as tinnitus (ringing, buzzing, whistling or humming in the ears). Therefore, risk assessment and the implementation of appropriate controls for these hazards are essential.
2. Appropriate controls to reduce the risk may include actions such as damping materials to prevent workpieces from "ringing".
3. Use hearing protection in accordance with employer's instructions and as required by occupational health and safety regulations.
4. Operate and maintain the assembly power tool for non-threaded mechanical fasteners as recommended in the instruction handbook, to prevent an unnecessary increase in the noise level.
5. Select, maintain and replace the consumable/inserted tool as recommended in the instruction handbook, to prevent an unnecessary increase in noise.
6. If the power tool has a silencer, always ensure that it is in place and in good working order when the power tool is being operated.

VIBRATION HAZARDS:

1. Exposure to vibration can cause disabling damage to the nerves and blood supply of the hands and arms.
2. Wear warm clothing when working in cold conditions and keep your hands warm and dry.
3. If you experience numbness, tingling, pain or whitening of the skin in your fingers or hands, stop using the assembly power tool for non-threaded mechanical fasteners, tell your employer and consult a physician.
4. Support the weight of the tool in a stand, tensioner or balancer, because a lighter grip can then be used to support the tool.

PRINCIPLE OF OPERATION



When the actuator assy-air is depressed, the pressurized air inside of the tool is released allowing spring pressure to move the valve spool assy causing the air to be redirected. The air is directed to the top of the air piston assy, moving it in a downward direction. The air below the air piston assy is then directed through the valve sleeve and exhausted out of the bottom of the tool. Simultaneously, the piston rod assy, connected to the air piston assy, is also moving down, forcing hydraulic oil up and into the front side of the head cylinder assy, causing the piston to move to the rear of the head cylinder assy. The internal components of the attached nose assembly are also moving with the piston to start the fastener installation. When the fastener installation is completed the actuator assy-air is released. Air pressure is then built up inside of the handle assy causing the valve spool assy to return to its original position and reversing the sequence. Spring pressure then returns the head piston to the forward position.

PULL Cycle

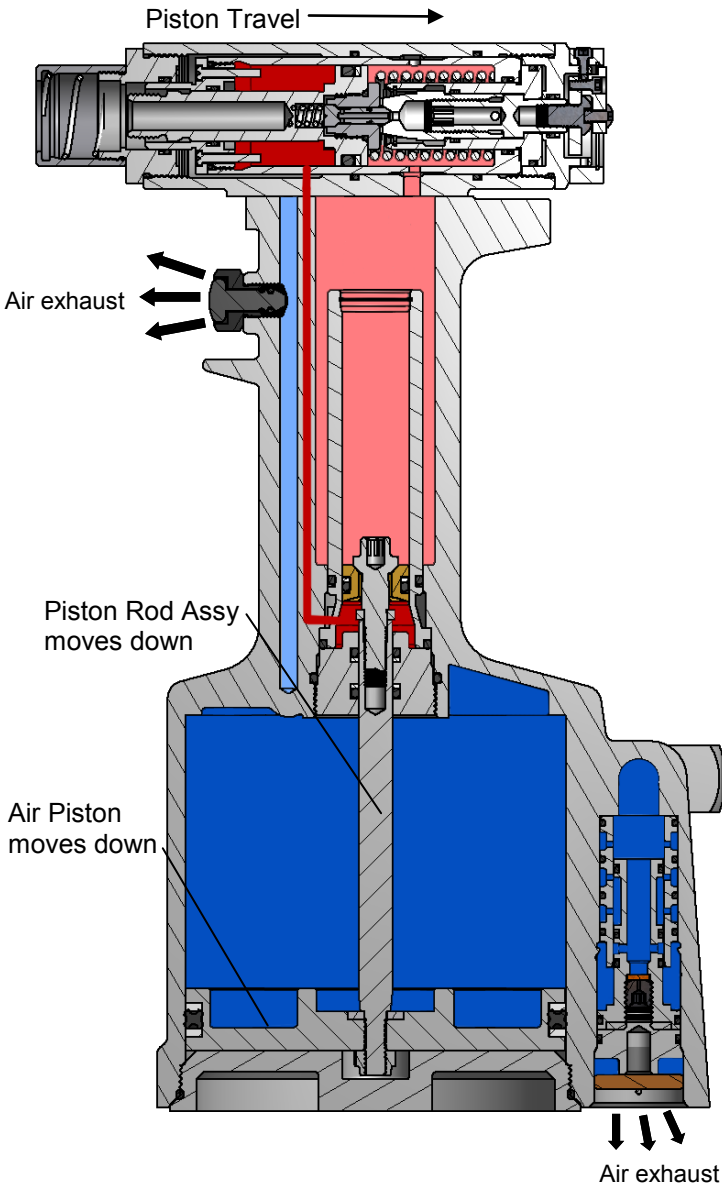

RETURN Cycle

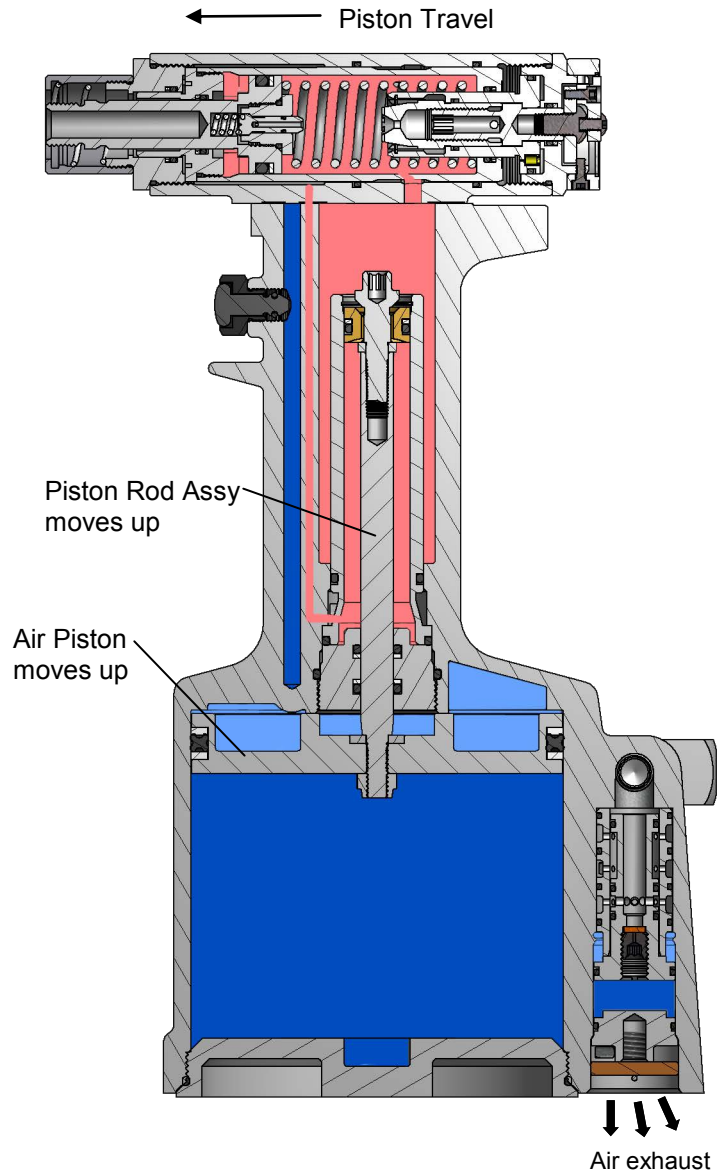

- Pressurized Oil
- Pressurized Air
- Return Oil
- Unpressurized Air

Images may not reflect actual tool

HOW TO SET-UP THE GB784



- ⚠ WARNING:** Only qualified and trained operators should install, adjust or use the assembly power tool for non-threaded mechanical fasteners.
- ⚠ WARNING:** Operator **MUST** read and understand all warnings and cautions.
- ⚠ WARNING:** It is required that eye protection, hearing protection and safety boots be worn at all times while handling this equipment.
- ⚠ WARNING:** The users or the user's employer should assess specific risks that could be present as a result after each use based on their application.
 - *Be sure there is adequate clearance for tool and operator's hands before proceeding. Keep fingers clear of any moving parts. Keep fingers clear from fasteners and installed materials. Severe personal injury may result.*
 - *Verify the air lines and/or hydraulic hoses are not a trip hazard.*
 - *Ensure that there are no electrical cables, gas pipes, etc., which can cause a hazard if damaged by the tool*
- ⚠ WARNING:** Do not pull fastener in the air. Personal injury from fastener ejecting may occur.
- ⚠ WARNING:** Air is exhausted from the bottom of the tool. Direct bottom of the tool (exhausted air) away from operator, other persons working in the vicinity, foreign matter and liquid.
- ⚠ WARNING:** Do not carry from hoses or use as a hammer.
- ⚠ WARNING:** Do not use in explosive atmosphere.
- ⚠ WARNING:** Ensure air hose is securely connected to avoid possible hose whipping.
- ⚠ WARNING:** Always disconnect air supply when tool is not in use to prevent accidental start-up.
- ⚠ WARNING:** Be sure there is adequate clearance for tool and operator hands.
- ⚠ CAUTION:** Do not use beyond the design intent.

The tool is shipped with a red plastic plug in the air inlet connector. The connector has a 1/4-18 female pipe thread to accept user air hose fitting. The tool comes with oil and is ready to use.

1. Remove red plastic shipping plug from air inlet Swivel (A-249) and screw in your quick disconnect (air) fitting.
2. Connect tool to air hose with 90 psi. (6.2 bar). 3/8 minimum diameter air line is mandatory. Cycle tool five times by depressing and releasing actuator. (Clean dry air is mandatory).
3. Disconnect air hose from tool.
4. Select proper nose assembly (see accessories pg. 21 for more information). Screw collet onto piston and slide anvil over collet and secure with nut (784101). (See proper data sheet for further instructions.)
5. Connect air supply.

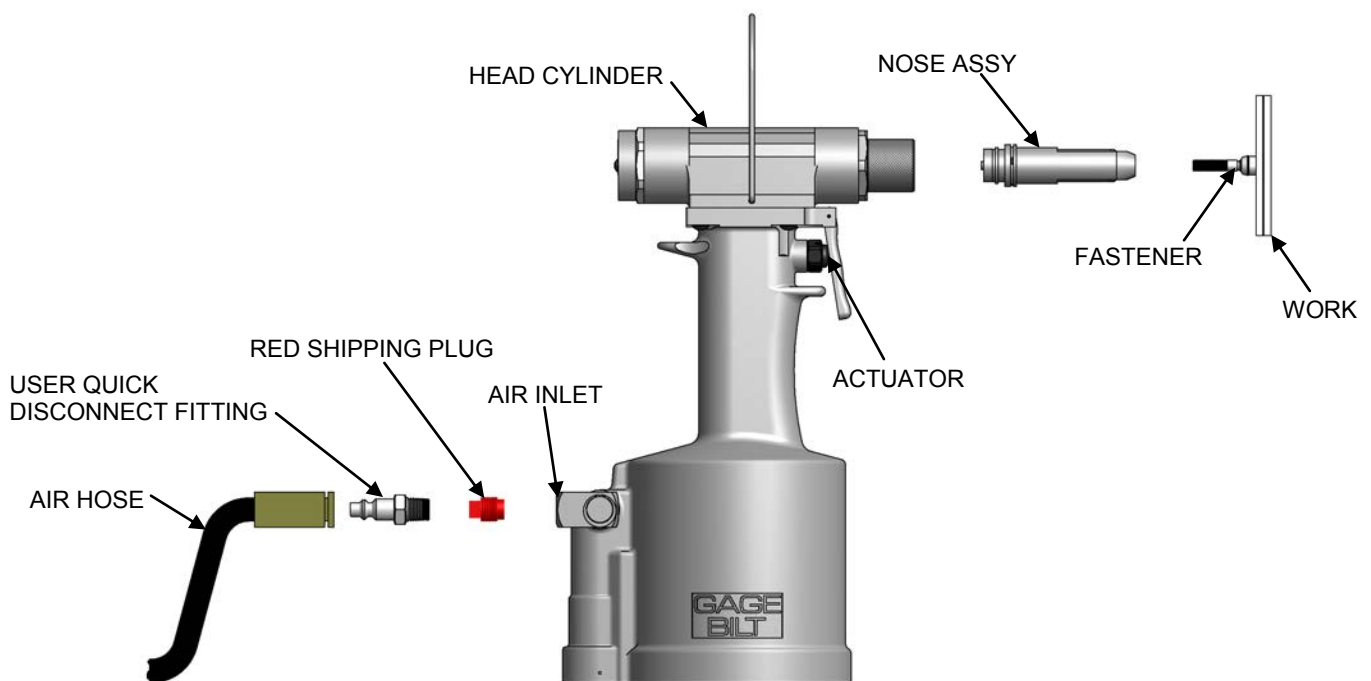

Image may not reflect actual tool



- ⚠ WARNING:** Only qualified and trained operators should install, adjust or use the assembly power tool for non-threaded mechanical fasteners.
- ⚠ WARNING:** Operator **MUST** read and understand all warnings and cautions.
- ⚠ WARNING:** It is required that eye protection, hearing protection and safety boots be worn at all times while handling this equipment.
- ⚠ WARNING:** The users or the user's employer should assess specific risks that could be present as a result after each use based on their application.
 - *Be sure there is adequate clearance for tool and operator's hands before proceeding. Keep fingers clear of any moving parts. Keep fingers clear from fasteners and installed materials. Severe personal injury may result.*
 - *Verify the air lines and/or hydraulic hoses are not a trip hazard.*
 - *Ensure that there are no electrical cables, gas pipes, etc., which can cause a hazard if damaged by the tool*
- ⚠ WARNING:** Do not pull fastener in the air. Personal injury from fastener ejecting may occur.
- ⚠ WARNING:** Air is exhausted from the bottom of the tool. Direct bottom of the tool (exhausted air) away from operator, other persons working in the vicinity, foreign matter and liquid.
- ⚠ WARNING:** Do not carry from hoses or use as a hammer.
- ⚠ WARNING:** Do not use in explosive atmosphere.
- ⚠ WARNING:** Ensure air hose is securely connected to avoid possible hose whipping.
- ⚠ WARNING:** Always disconnect air supply when tool is not in use to prevent accidental start-up.
- ⚠ WARNING:** Be sure there is adequate clearance for tool and operator hands.
- ⚠ CAUTION:** Do not use beyond the design intent.

Blind Fasteners

1. Insert fastener.



2. Insert fastener into nose assembly.



3. Press actuator to start cycle.



4. Release actuator as soon as fastener breaks.
5. Repeat steps 1-4.

Images may not reflect actual tool or fastener

DAILY MAINTENANCE



- ⚠ WARNING:** Tool must be maintained in a safe working condition at all times and examined on a daily basis for damage or wear. Any repair should be done by qualified personnel trained on Gage Bilt procedures.
- ⚠ WARNING:** Excessive contact with hydraulic oil and lubricants should be avoided.
- ⚠ WARNING:** Maintenance personnel **MUST** read and understand all warnings and cautions.
- ⚠ WARNING:** Disconnect tool from its power source before performing maintenance, cleaning or when replacing worn or damaged components. Severe personal injury may occur if power source is not disconnected.
- ⚠ WARNING:** Read SDS documents for all applicable materials.

Note:

- Dispose of hydraulic oil in accordance with manufacture safety datasheet.
- All tool materials are recyclable except rubber o'rings, seals and wipers.

The performance of any tool depends upon good maintenance practices. Following these minimal requirements daily will extend the life of your tool.

- *Only use a clean dry air supply set at 90-100 p.s.i. (6.2-6.9 bar) Max. equipped with a filter-regulator to prevent wear.
- * Check tool and nose assembly for damage. (Replace/Repair if necessary). See overhaul (pgs. 13-15) for tool repair.
- * Inspect hoses and couplings for wear, damage and leaks. (Replace/Repair if necessary).
- * Verify that hydraulic hose fittings and couplings, air and electrical connections are secure. Tighten, Replace or Repair if necessary
- * Cycle the tool several times to assure there are no leaks during use.
- * Keep hydraulic system free of dirt.
- * Proper care by operators is necessary in maintaining full productivity and reducing downtime.
- * Keep nose assemblies, especially jaws, clean and free of chips and debris. Lube jaws and collet surfaces that jaws ride on with light machine oil on a daily basis.
- * All Screwed End Caps, Base Covers, Air Fittings, Air Actuators, Screws and Nose Assemblies are to be examined at the end of each working shift to check that they are secure.
- * For a complete overhaul, service tool kit (GB784TK) is recommended. (See overhaul pgs. 13-15).

WEEKLY MAINTENANCE

- Keep the hydraulic system full (only use Dexron® III or equivalent) and free of air by using the air bleeder assy (704153) on a weekly basis or as needed. (See Filling and procedure pg. 11).

SEE TROUBLESHOOTING (PG.12) AND OVERHAUL (PGS. 13-15) FOR FURTHER GUIDANCE.

CLEANING AND LUBRICATING PROCEDURE

Daily cleaning and lubrication of nose assembly will greatly reduce downtime and increase life of components. Using sewing machine oil, or an equivalent cleaner/lubricant, follow instructions below.

CLEANING

Clean nose assy daily or as often as needed.

1. Dip nose assy into mineral spirits or similar solvent to clean jaws and wash away metal chips and debris. **DO NOT** allow jaws to come in contact with other solvents. **DO NOT** let jaws soak. Dry jaws immediately.
2. Disassemble nose assy and use a sharp "pick" to remove embedded particles from grooves of jaws.

LUBRICATING

Lubricate nose assy after each cleaning and as often as needed.

1. Disconnect tool vacuum line (if equipped).
2. Point nose assembly into oil as shown.
3. Cycle tool 8-10 times and wipe dry.

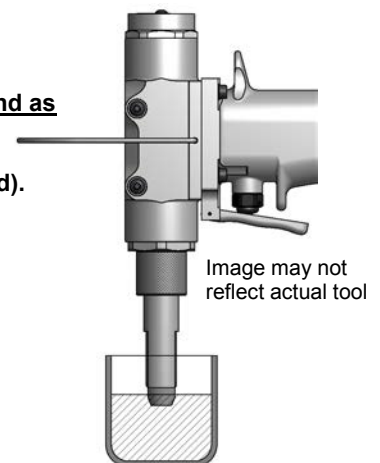

TORQUE SPECIFICATIONS

- Socket Head Cap Screws (400061) = 40 inch lbs.
- Button Head Cap Screws (402479) = 40 inch lbs.
- Packing Plug (744118) = 45 foot lbs.
- Flexlock Nut (400559) = 40 inch lbs.
- Rear Cap (784132) = 140 foot lbs.
- Front Cap (784103) = 140 foot lbs.
- Button Head Cap Screws (402482) = 35-40 inch lbs. (*Do NOT over-tighten*)

FILLING AND BLEEDING PROCEDURE



- ⚠ WARNING:** Do not cycle tool without air bleeder assy (704153) (sold separately), or the screw and stat-o-seal, installed in tool head. Severe personal injury could result.
- ⚠ WARNING:** Use CAUTION when removing screws, air bleeder assy (704153) and fill bottle assy (745263) (Sold separately). Hydraulic oil may be under pressure.
- ⚠ CAUTION:** Before filling handle assy (744129), air piston assy (744121) should be all the way down.
- ⚠ CAUTION:** When forcing piston rod assy (744136) downward, with head cylinder (784221) removed, hydraulic oil will eject forcibly from handle assy (744129).
- ⚠ CAUTION:** When bleeding tool, ensure tubing is free from kinks or other obstructions.

Note:

- Air Bleeder Assy (704153) & Fill Bottle (745263) (sold separately) is required.

Should it become necessary to completely refill the tool (such as would be required after tool has been dismantled and reassembled), take the following steps after depressing actuator assy-air **AND DISCONNECTING THE AIR SUPPLY:**

1. Remove head cylinder (784221) from handle assembly (744129). Slowly push head piston (784112) completely forward. Remove adjusting ring (784138). Turn adjuster knob assy (784139) completely in clockwise, then back out two turns counterclockwise. This will set gage point #1 very close. It will need to be readjusted slightly after bleeding is complete using stroke setting gage (784159).
2. Fill handle assy (744129) and the oil passage on top of handle assy (744129) with automatic oil, Dexron® III or equivalent. When looking at the top of the handle assy (744129), the oil passage is the hole that is counterbored for S832 o'ring.
3. Replace head cylinder (784221) with care, ensuring gasket (704129) and o'ring (S832) are properly installed. Tighten and torque button head cap screws (402479) uniformly to 40 inch lbs. to prevent leakage around gasket.
4. Lay tool on its side with the button-head cap screws (402482) and stat-o-seals (S572) facing up. Remove button-head cap screw (402482) and stat-o-seal (S572) from the front and rear hole. Attach the fill bottle (745263) (sold separately) filled with automatic transmission oil, Dexron® III or equivalent, to the front hole and squeeze the fill bottle (745263) (sold separately) until oil flows freely from the rear hole and air bubbles stop appearing at rear hole.

NOTE:

If oil does not flow freely, remove base cover and push air piston up about 1 in. (25.4 mm). This will open the oil valve on the piston rod assy (744136). Replace base cover. Repeat step #4.

5. Remove fill bottle (745263) (sold separately) from front hole and attach fill bottle (745263) (sold separately) to rear hole and reverse step #4.
6. Install button head cap screw (402482) and stat-o-seal (S572) to front hole and torque 35-40 inch lbs. Do not over tighten.
7. Stand tool up. Remove button head cap screw (402482) and stat-o-seal (S572) from rear hole. Install air bleeder assy (704153) (sold separately) to rear hole and connect tool to air line. Cycle ten to twenty times to fully circulate oil through hydraulic system.
8. **DISCONNECT AIR FROM TOOL.** Remove air bleeder assy (704153) (sold separately). Install button head cap screw (402482) and stat-o-seal (S572). Torque to 35-40 in. lbs. Do not over tighten. Reconnect air and cycle tool 10 more times. Check tool stroke of .875" (22.2 mm) Min. We recommend using dial calipers. With the actuator assy-air (704130) released, check dimension (A). Holding actuator assy-air (704130) in, check dimension (B). Add dimension (A) to dimension (B). If stroke is not consistent within 1/64" (.396 mm) repeat steps 7-8.

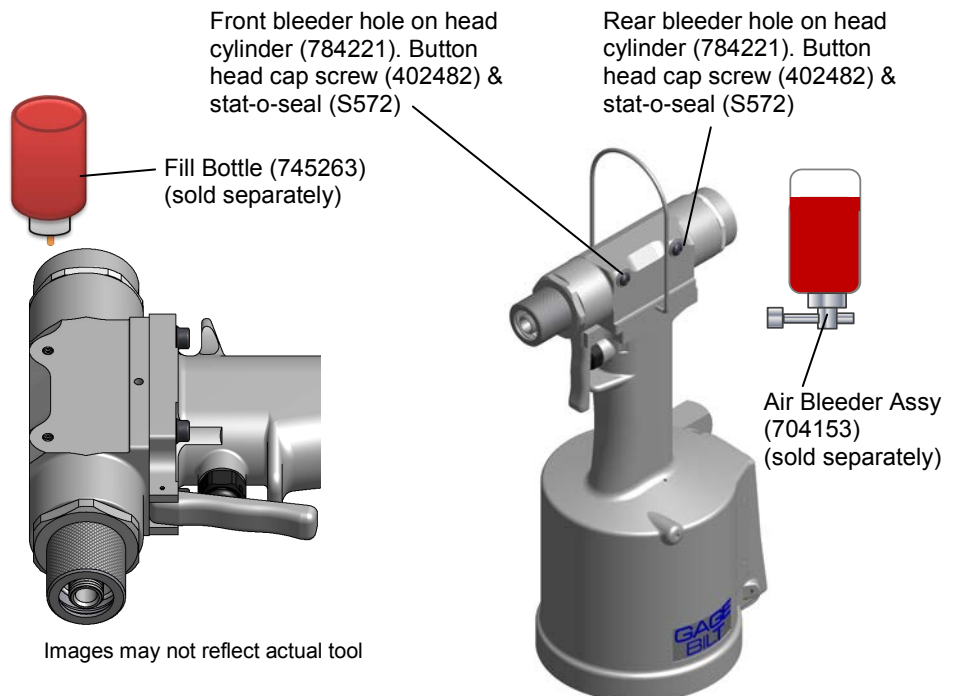
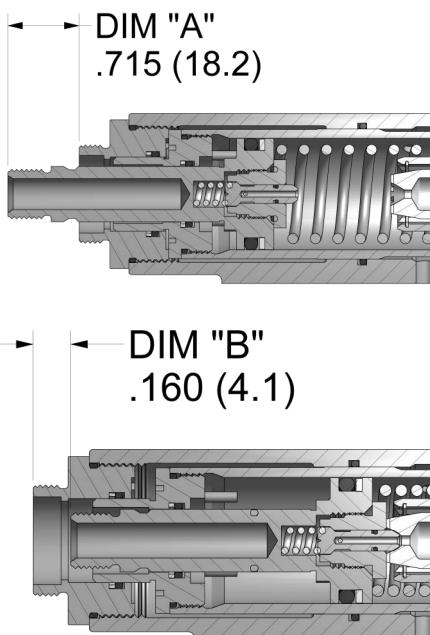



Providing all maintenance conditions have been met, follow this systematic approach to diagnosis.

1. **MORE THAN ONE PULL IS REQUIRED TO BREAK FASTENER.**
 - a) Tool needs to be bled. (See filling and bleeding procedure pg. 11).
 - b) Spring has fatigued, replace.
 - c) Jaws are stripped or packed with chips. Clean or replace.
 - d) Incorrect nose tip.

2. **SLOW OR PARTIAL OPERATION WHEN THE ACTUATOR LEVER ASSY (704343) IS DEPRESSED**
 - a) O'rings (400845) and back-up ring (S657) on the head piston (784112) could be worn or damaged. Replace.
 - b) O'ring (A-201) and back-up ring (S908) on the piston rod assy (744136) could be worn or damaged. Replace.
 - c) Muffler (744143) or filter inside valve spool assy (743142) may be plugged. Clean thoroughly and back-blow with compressed air.
 - d) Hole in metering screw in valve spool assy (743142) may be blocked or damaged. Hole diameter should be .028" (.71 mm). Clear and size or replace.

3. **NO OPERATION WHEN ACTUATOR LEVER ASSY (704343) IS DEPRESSED**
 - a) Tool seized due to mechanical failure or damaged parts.

4. **OIL LEAKAGE**
 - a) **DO NOT** OPERATE WITH OIL LEAKING FROM TOOL. HIGH PRESSURE OIL MAY CAUSE SEVERE PERSONAL INJURY.
 - b) Any oil leaking externally should be traced to its source. An o'ring or seal that leaks should be replaced.

5. **AIR BYPASS FROM VALVE HOUSING**
 - a) If the spring (744144) breaks or dislodges, air will flow freely through the muffler (744143). Replace or reset. Valve spring installation tool (744251) is recommended.
 - b) Check o'rings on valve sleeve (743144), valve spool assy (743142), and valve plug (744142). If worn or damaged, replace. Valve sleeve removal tool (744152) is recommended.

6. **FASTENER STEM JAMMED IN NOSE ASSEMBLY**
 - a) Nose assembly components require service. **DISCONNECT AIR FROM TOOL**, remove the nose from the tool and disassemble. Replace worn or broken parts. Clean the surface the jaws ride on.
 - b) Stems lodged side by side in the follower. Disassemble, remove stems, and reassemble.
 - c) Incorrect follower.



- ⚠ WARNING:** Only qualified and trained personnel should perform overhaul.
- ⚠ WARNING:** Personnel must read and understand all warnings and cautions.
- ⚠ WARNING:** Tool must be maintained in a safe working condition at all times and examined on a daily basis for damage or wear. Any repair should be done by qualified personnel trained on Gage Bilt procedures.
- ⚠ WARNING:** Disconnect tool from its power source before performing overhaul. Severe personal injury may occur if power source is not disconnected.
- ⚠ WARNING:** Excessive contact with hydraulic oil and lubricants should be avoided (See SDS documents for all applicable materials).
- ⚠ WARNING:** When operating, repairing or overhauling tool, wear approved eye protection. Do not look in front of tool or rear of tool when installing fastener.
- ⚠ WARNING:** Ensure air hose is securely connected to avoid possible hose whipping (Air Actuated Tools only).
- ⚠ WARNING:** Depress actuator assy-air (704130) and disconnect from air, with the piston in the rear position, before overhaul. Severe personal injury may occur if air hose is not disconnected. **USE CAUTION** when forcing piston rod assy downward with head cylinder removed. Hydraulic oil will eject forcibly from handle assy.

Note:

- Dispose of hydraulic oil in accordance with manufacture safety datasheet.
- All tool materials are recyclable except rubber o’rings, seals and wipers.

Perform overhaul in a clean, well lit area using care not to scratch or nick any smooth surface that comes in contact with an o’ring. Use of Lubriplate® (Gage Bilt part no. 402723) or other lubricant is recommended during reassembly to prevent tearing or distorting of o’rings.

The disassembly and re-assembly procedure can be accomplished by utilizing the following instructions and parts lists on pgs. 13-17. Use extreme care during disassembly and re-assembly not to mar or nick any smooth surface that comes in contact with seals. Before installing seals, always apply a good lubricant, such as Lubriplate, to the surfaces. It is recommended that service tool kit (GB784TK) be used to facilitate overhaul. A complete overhaul can be achieved by the use of Service Kit (784004) which contains a complete set of o’rings, back-up rings, screws, washers and gasket.

Clean parts in mineral spirits or other o’ring compatible solvent being sure to clean o’ring grooves. Inspect components for scoring, excessive wear or damage.

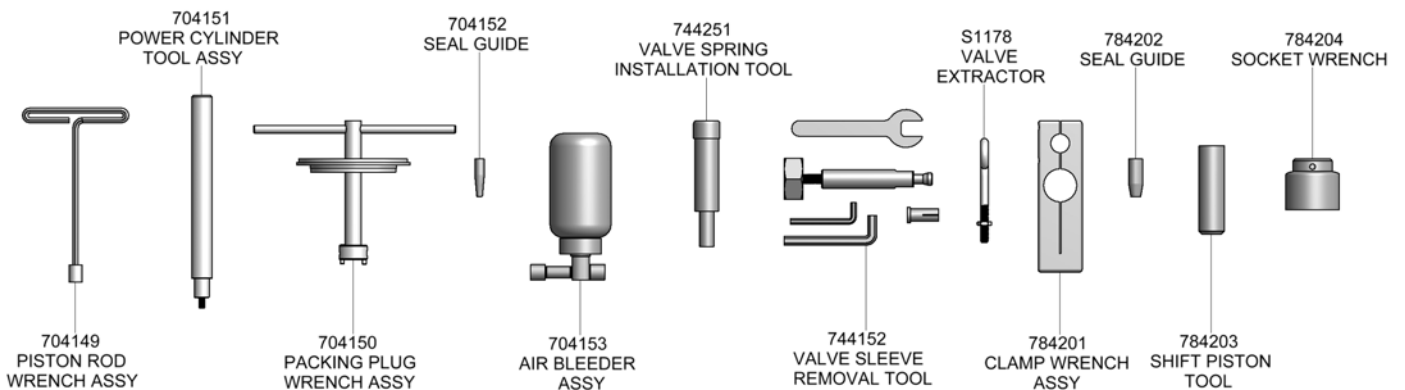

GB784TK Service Tool Kit Includes:

Part No.	Description
704149	Piston Rod Wrench Assy
704151	Power Cylinder Tool Assy
704150	Packing Plug Wrench Assy
704152	Seal Guide
704153	Air Bleeder Assy
744251	Valve Spring Installation Tool
744152	Valve Sleeve Removal Tool
S1178	Valve Extractor
784201	Clamp Wrench Assy
784202	Seal Guide
784203	Shift Piston Tool
784204	Socket Wrench

TOOL DISPOSAL

1. When tool life is met, drain hydraulic oil from tool and dispose of the hydraulic oil in accordance with SDS datasheet and all environmental regulations applicable to your area.
2. Disassemble tool and remove all rubber o’rings, seals, wipers and hydraulic hoses. All tool materials are recyclable except rubber o’rings, seals, wipers and hydraulic hoses. Dispose of rubber materials in accordance with all environmental regulations applicable in your area.



ACTUATOR ASSY-AIR

- ⚠ WARNING:** Disconnect tool from its power source before actuator removal or installation. Severe personal injury may occur if power source is not disconnected.
- ⚠ CAUTION:** Actuator assy-air (704130) can break if not careful.
- ⚠ CAUTION:** Do not over tighten actuator assy-air (704130). Snug tighten only.

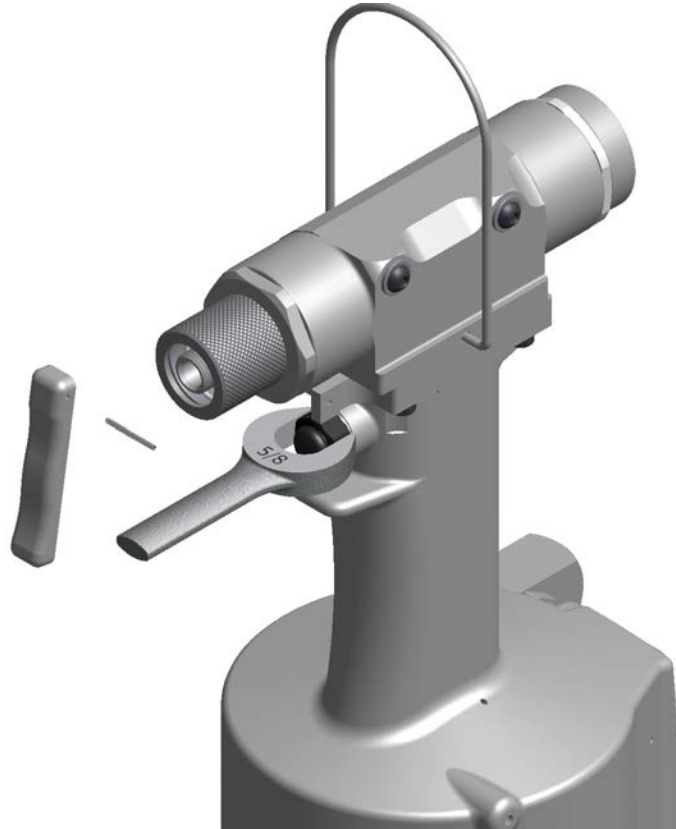

REMOVING ACTUATOR ASSY-AIR (704130)

1. Remove actuator lever assy (704343) including pin-slotted (400608) from the handle assy (744129).
2. Insert a 5/8" open end wrench around actuator assy-air (704130).
3. Loosen the actuator assy-air (704130).
4. Remove wrench. Unthread and remove the actuator assy-air (704130) with fingers from the handle assy (744129).

INSTALLING ACTUATOR ASSY-AIR (704130)

1. Apply Teflon® tape onto threads of actuator assy-air (704130) one to two wraps.
2. Thread the actuator assy-air (704130) all the way into handle assy (744129) with fingers.
3. Insert and turn 5/8" open end wrench and snug tight approximately 1/4-1/2 turn.
4. Re-attach actuator lever assy (704343) including pin-slotted (400608) to the handle assy (744129).



⚠ WARNING: Disconnect tool from its air source before disassembly.

⚠ CAUTION: Spring piston (784124) will eject outward when removing piston cap (784108) during shift piston (784125) disassembly.

HEAD

1. Remove nose assembly and adapter from tool before attempting disassembly of head cylinder (784221).
2. Loosen and remove (4) button head cap screws (402479) and remove head cylinder (784221) from handle assy (744129).
3. Place head cylinder (784221) in a vise vertically with the front cap (784103) upwards.
4. Remove front cap (784103) with socket wrench (784204) from maintenance tool kit (GB784TK). Remove (4) piston stops (784107).
5. Turn the head cylinder (784221) in the vise so the rear cap (784132) is upwards. Remove the (2) socket head cap screws (405334) and adjuster knob assy (784139) with a 3/32 hex key. Remove the adjusting ring (784138).
6. Remove the rear cap (784132). Push the head piston (784112) towards the rear to remove the shift piston (784125).
Note: Valve (784116), valve seat (784119) and shift stop (784127) must be replaced as a valve assembly (784118).

The re-assembly sequence is the opposite of disassembly. (See Filling and Bleeding procedure pg. 11). Apply Loctite #242 and torque the button head cap screws (402479) uniformly to 40 inch lbs. to prevent leakage around the gasket (745124).

SHIFT PISTON DISASSEMBLY

1. Clamp the shift piston (784125) into the large hole of clamp wrench assy (784201), locating on a polished surface. Tighten the cap screws on the clamp wrench assy (784201) securely.
2. Place the clamp wrench assy (784201) in a vise so the shift piston (784125) is facing upward.
3. Place shift piston tool (784203) over the threads and against the shoulder of the head piston (784112) to protect the seals.
4. Remove the piston cap (784108) with a second clamp wrench assy (784201) tightened around the smaller hole.
5. Remove the valve seat (784119) with an 11/16" wrench.
6. Remove the valve (784116) and valve spring (784115).

REAR CAP DISASSEMBLY

1. Using a 5/32" hex key, turn socket head cap screw (405334), attached to adjuster knob assy (784139), counterclockwise until it stops. Remove the retaining ring (S768) with a sharp or pointed instrument. The socket head cap screw (405334) can then be turned clockwise so the shift stop (784127) can be removed.
2. Remove the shift screw (784128) with a 3/16" hex key. Hold socket head cap screw (405334) with a 5/32" hex wrench.
3. Remove the socket head cap screw (405334) and index washer (784136).
4. Push the shift screw (784128) out.
5. Remove the release piston assy (784130) from the rear cap (784132).

Note: After servicing the tool, to reassemble, reverse the above procedures. Make sure to use proper tools and tighten all parts to manual torque specifications. (See page 10).



⚠ WARNING: Disconnect tool from its air source before disassembly.

HANDLE

To inspect air cylinder bore, remove base cover (744124). Any further disassembly will require removal of the head cylinder (784221) first.

For complete disassembly.

1. Remove base cover (744124).
2. Holding tool upright, remove four button-head cap screws (402479). Lift head cylinder (784221) from handle assy (744129) and set aside o-ring (S832) and gasket (704129).
3. Empty all hydraulic oil into an approved container and dispose of in accordance with all environmental regulations applicable to your area.
4. Place piston rod wrench assy (704149) down into top of power cylinder (743131) and into the hex of piston rod assy (744136). While holding the piston rod wrench assy (704149), remove flexlock nut (400559) using a 7/16" socket wrench. Still holding piston rod wrench assy (704149), remove air piston assy (744121) using packing plug wrench assy (704150), by turning counterclockwise.
5. When air piston assy (744121) is completely free from piston rod assy (744136), tap or push on the piston rod wrench to eject air piston assy (744121) from bottom of handle assy (744129).
6. After removal of air piston assy (744121), slide piston rod assy (744136) back up to the end of its travel. Using packing plug wrench assy (704150) remove packing plug (744118).
7. With packing plug (744118) removed, power cylinder (743131) can be removed by pushing on power cylinder tool assy (704151) when inserted into top of power cylinder (743131).

To reassemble the handle assy (744129).

1. Reverse the above procedure, being certain that all o-rings are properly lubricated before installation. Torque packing plug (744118) to 45 foot lbs.
2. Attach the seal guide (704152) to the piston rod assy (744136) and tap the piston rod assy (744136) through the packing plug (744118).
3. Attach air piston assy (744121) and flexlock nut (400559). Torque flexlock nut to 40 inch lbs.
4. Attach air piston assy (744121) to piston rod assy (744136).
5. With the piston rod in the down position, fill oil passage on top of handle assy (744129) with automatic transmission oil, Dexron III or equivalent. When looking at top of handle assy (744129) the oil passage is the hole that has a counterbore for (S832) o-ring.
6. Replace gasket (704129) and o-ring (S832), just prior to replacing head cylinder (784221). Torque all screws to manual specifications. (See Filling & Bleeding procedure pg. 11) & (See torque specs. pg. 10).

AIR VALVE

1. Remove pin (744149) and muffler (744143).
2. Insert valve extractor (S1178) into end of valve plug (744142) and pull it out.
3. Using the same procedure, pull out valve spool assy (743142).
4. It should never be necessary to remove valve sleeve (743144) unless the ports in the valve sleeve (743144) are plugged from contaminated air. If ports are plugged, use needle nose pliers to grasp end of spring (744144), turning clockwise and pulling to dislodge from groove in casting. Valve spring installation tool (744251) will facilitate the proper installation of the spring (744144).
5. Valve sleeve (743144) can be pulled out using valve sleeve removal tool (744152).

PARTS LIST



⚠ 784118 VALVE ASSY INCL: 784116, 70412, S298, 784119 & 784127

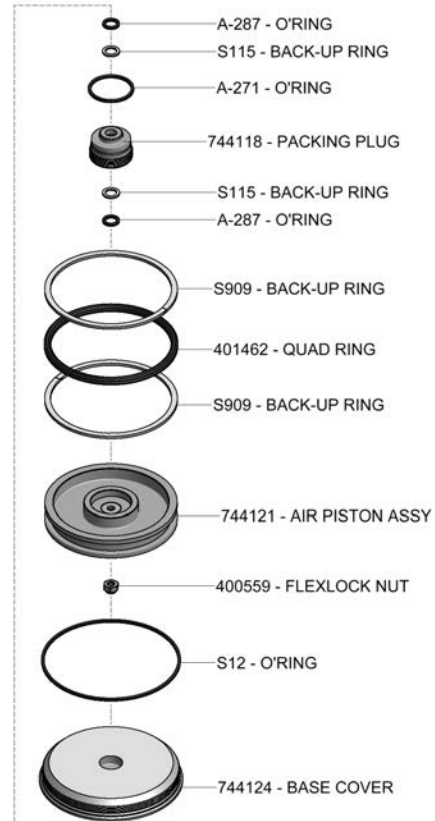
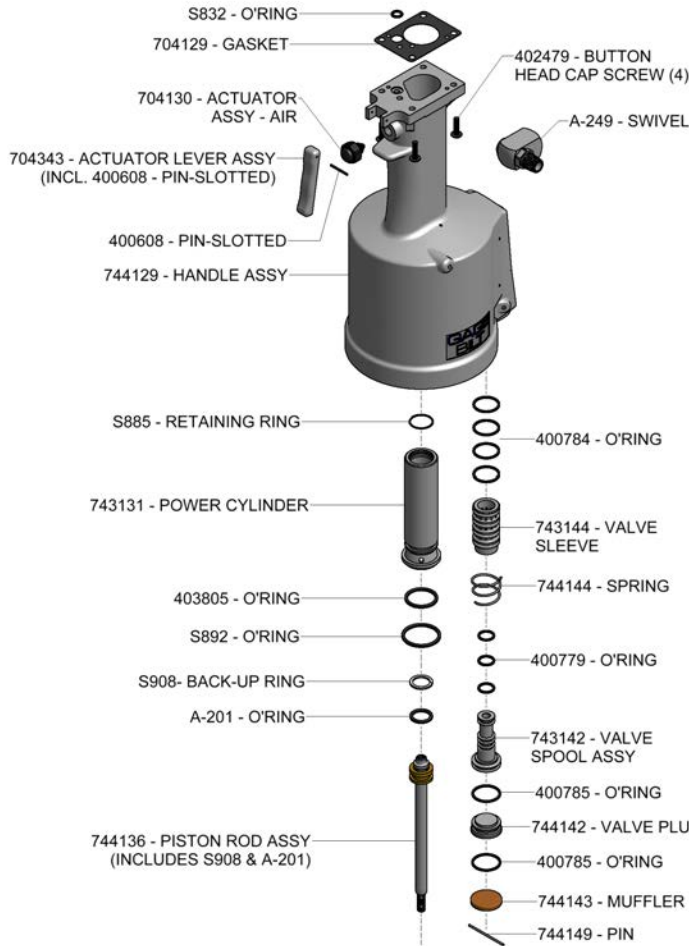
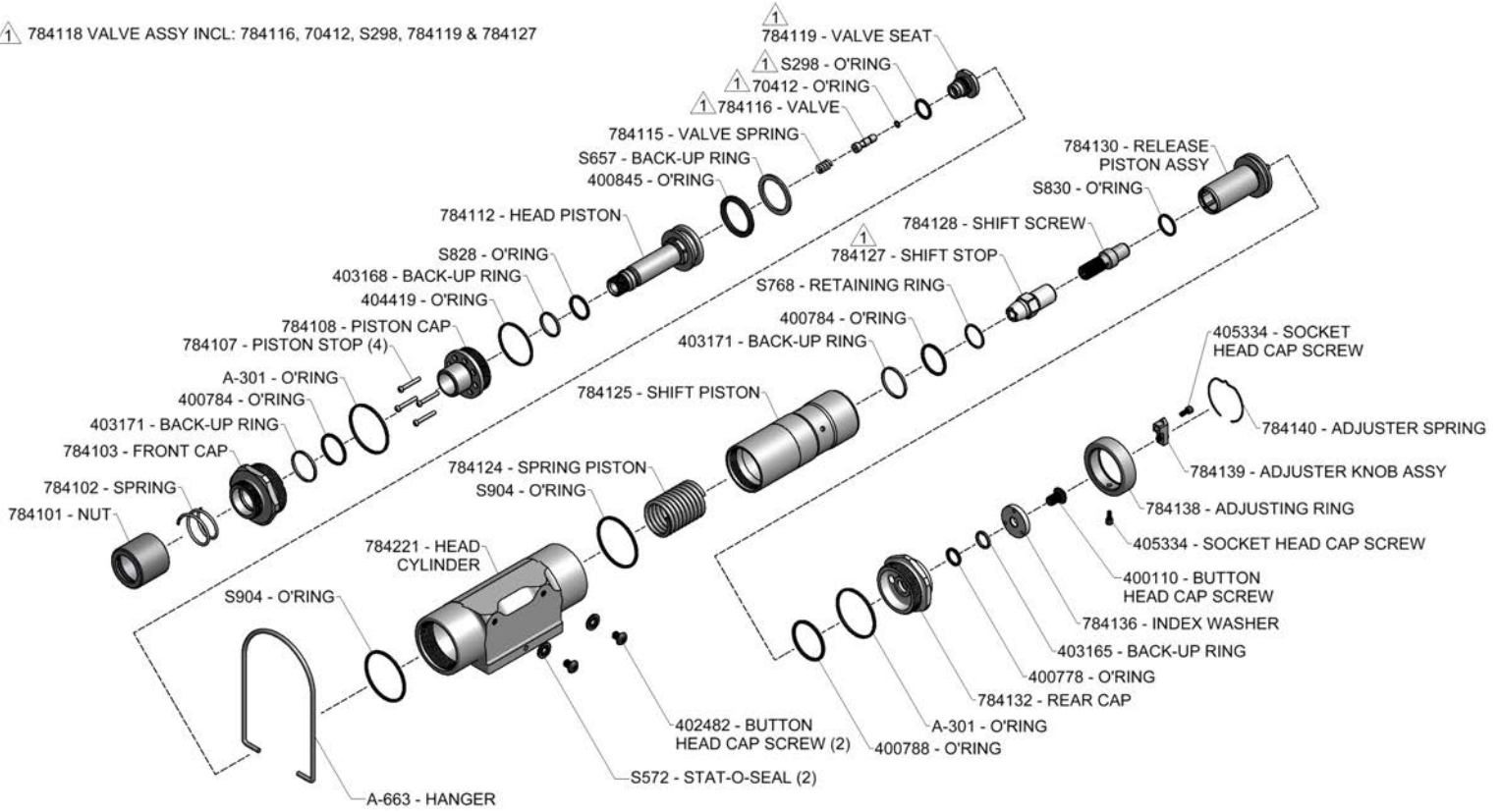

DEXRON® III OIL SAFETY DATA

FIRST AID MEASURES

Eye: No specific first aid measures are required. As a precaution, remove contact lenses, if worn, and flush eyes with water.

Skin: No specific first aid measures are required. As a precaution, remove clothing and shoes if contaminated. To remove the material from skin, use soap and water. Discard contaminated clothing and shoes or thoroughly clean before reuse.

Ingestion: No specific first aid measures are required. Do not induce vomiting. As a precaution, get medical advice.

Inhalation: No specific first aid measures are required. If exposed to excessive levels of material in the air, move the exposed person to fresh air. Get medical attention if coughing or respiratory discomfort occurs.

Note to Physicians: In an accident involving high-pressure equipment, this product may be injected under the skin. Such an accident may result in a small, sometimes bloodless, puncture wound. However, because of its driving force, material injected into a fingertip can be deposited into the palm of the hand. Within 24 hours, there is usually a great deal of swelling, discoloration, and intense throbbing pain. Immediate treatment at a surgical emergency center is recommended.

FIRE

Leaks/ruptures in high pressure system using materials of this type can create a fire hazard when in the vicinity of ignition sources (eg. open flame, pilot lights, sparks, or electric arcs).

FLAMMABLE PROPERTIES:

Flashpoint: (Cleveland Open Cup) 178 °C (352 °F) Minimum

EXTINGUISHING MEDIA: Use water fog, foam, dry chemical or carbon dioxide (CO₂) to extinguish flames.

PROTECTION OF FIRE FIGHTERS:

Fire Fighting Instructions: This material will burn although it is not easily ignited. See Section 7 for proper handling and storage. For fires involving this material, do not enter any enclosed or confined fire space without proper protective equipment, including self-contained breathing apparatus.

Combustion Products: Highly dependent on combustion conditions. A complex mixture of airborne solids, liquids, and gases including carbon monoxide, carbon dioxide, and unidentified organic compounds will be evolved when this material undergoes combustion.

ACCIDENTAL RELEASE MEASURES

Protective Measures: Eliminate all sources of ignition in vicinity of spilled material.

Spill Management: Stop the source of the release if you can do it without risk. Contain release to prevent further contamination of soil, surface water or groundwater. Clean up spill as soon as possible. Use appropriate techniques such as applying non-combustible absorbent materials or pumping. Where feasible and appropriate, remove contaminated soil. Place contaminated materials in disposable containers and dispose of in a manner consistent with applicable regulations.

ECOLOGICAL INFORMATION

Waste disposal: In accordance with all environmental regulations applicable to your area.

Spillage: Prevent entry into drains, sewers and water course. Soak up with diatomaceous earth or other inert material. Store in appropriate container for disposal.

Ecotoxicity: This material is expected to be harmful to aquatic organisms and may cause long-term adverse effects in the aquatic environment. The ecotoxicity hazard is based on an evaluation of data for the components or a similar material.

HANDLING

Precautionary Measures: DO NOT USE IN HIGH PRESSURE SYSTEMS in the vicinity of flames, sparks and hot surfaces. Use only in well ventilated areas. Keep container closed. Keep out of the reach of children.

General Handling Information: Avoid contaminating soil or releasing this material into sewage and drainage systems and bodies of water.

Static Hazard: Electrostatic charge may accumulate and create a hazardous condition when handling this material. To minimize this hazard, bonding and grounding may be necessary but may not, by themselves, be sufficient. Review all operations which have the potential of generating and accumulating an electrostatic charge and/or a flammable atmosphere (including tank and container filling, splash filling, tank cleaning, sampling, gauging, switch loading, filtering, mixing, agitation, and vacuum truck operations) and use appropriate mitigating procedures.

DISPOSAL CONSIDERATIONS

Use material for its intended purpose or recycle if possible. Oil collection services are available for used oil recycling or disposal. Place contaminated materials in containers and dispose of in a manner consistent with applicable regulations.

SETTING THE SHIFT POINT:



⚠ CAUTION: Actuator must be released before turning adjuster knob.

The shift point must be adjusted to insure the flushness of the rivet stem after installation. To Adjust:

1. Connect the tool to a clean dry air source of 90 psi to 100 psi. (6.2-6.9 bar) Max. Remove nut.
2. Hand tighten small end of stroke setting gage (784159) onto piston.
3. Depress Actuator assy-air (704130) and hold. Gage point #1 should be flush with face of front cap as shown. Release the actuator assy-air (704130).
4. To increase gage protrusion, turn adjuster knob clockwise to increase gage protrusion or counter-clockwise to decrease gage protrusion. Cycle tool and recheck after making adjustments.

NOTE: Adjustment can only be made by one-half turn in either direction.

5. After tool is initially set and stem protrusion is out of specification, follow the steps listed below:

- a. If stem protrusion is too high, turn adjustment knob clockwise to lower.
- b. If stem protrusion is too low, turn adjustment knob counter clockwise to higher.

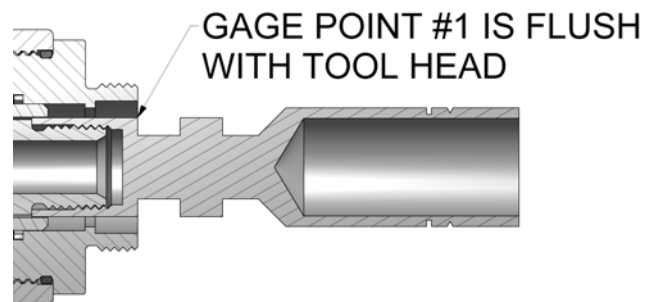
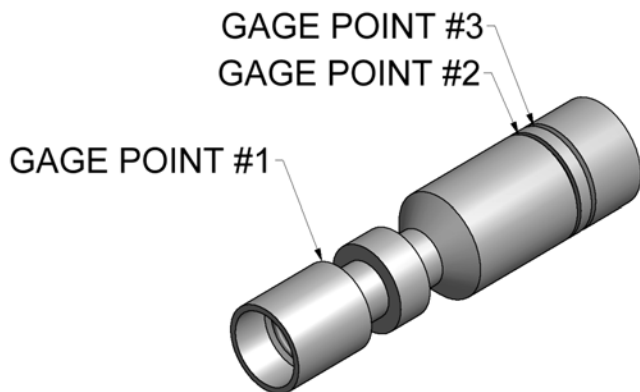
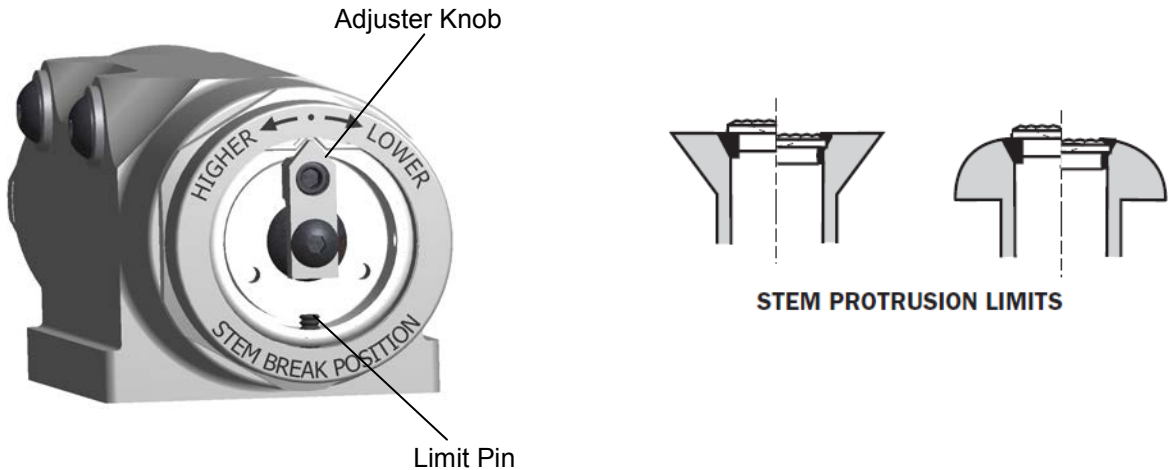

784159 - STROKE SETTING GAGE

SHIFT PISTON CHECK:

The shift piston should be checked to ensure that the shift stroke is complete.

1. Connect the tool to a clean dry air source of 90 psi to 100 psi. (6.2-6.9 bar) Max. Remove nut.
2. Install large unthreaded end of stroke setting gage (784159) over threads on head piston until it seats on pistons shoulder, gage point #2 must line up with front of tool as shown in figure A.
3. Depress and hold actuator assy-air (704130). The piston should shift gage in forward position exposing stroke setting gage point #3 in front of tool head as shown in figure B.
4. If tool fails to meet the above check, it should be overhauled.

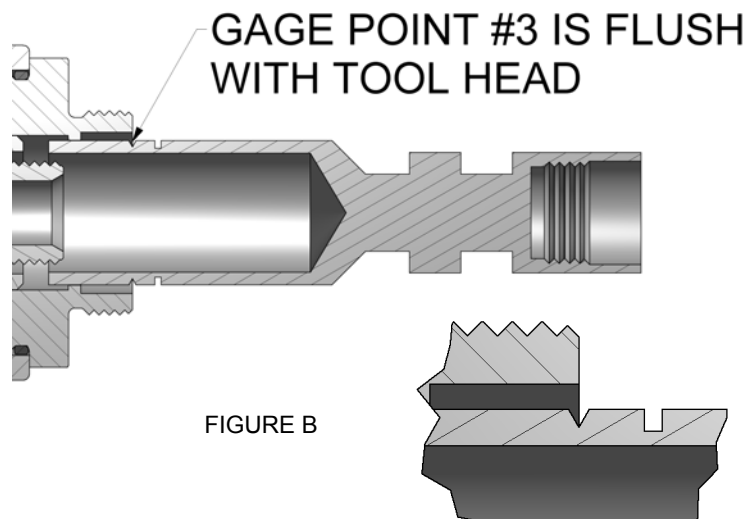
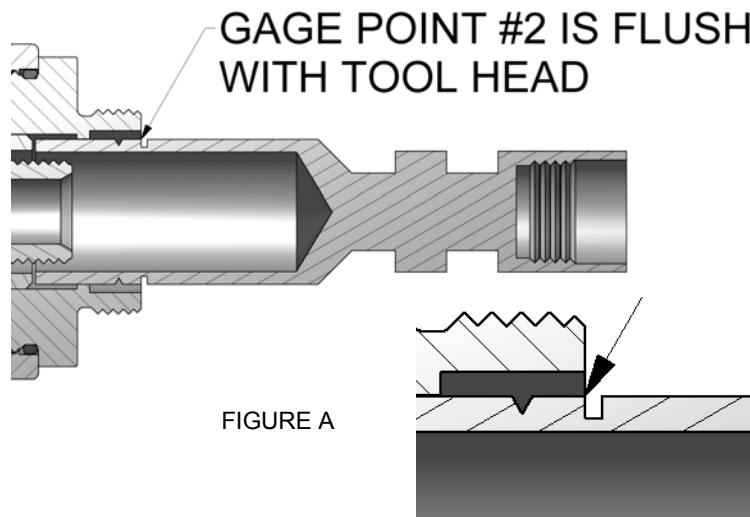

ACCESSORIES

(Sold Separately)



NOSE ASSEMBLY SELECTION CHART

Nose assemblies are not furnished with the tool and must be purchased separately. In ordering heads be sure to specify the shank diameter and head style (universal or countersunk) of the rivets to be installed.

The following pulling heads will fit directly on the GB784 Riveter. (NOTE: Cherry® 681 series pulling heads fit directly on the GB784).

681 PULLING HEADS FOR 2000 SERIES CHERRYLOCK® RIVETS CONFORMING TO NAS 1400 & NAS 1740

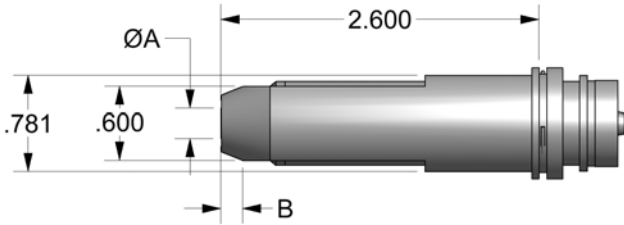

RIVET DIAMETER	NOSE ASSEMBLY	DIMENSION	
		A	B
3/32"	3U-681-25	.188	.348
3/32"	3C-681-25	.163	.332
1/8"	4U-681-25	.250	.341
1/8"	4C-681-25	.208	.377
5/32"	5U-681-25	.313	.377
5/32"	5C-681-25	.269	.352
3/16"	6U-681-25	.375	.418
3/16"	6C-681-25	.335	.386
1/4"	8U-681-25	.500	.452
1/4"	8C-681-25	.458	.398

INSTALLING 681 PULLING HEAD ON RIVETER

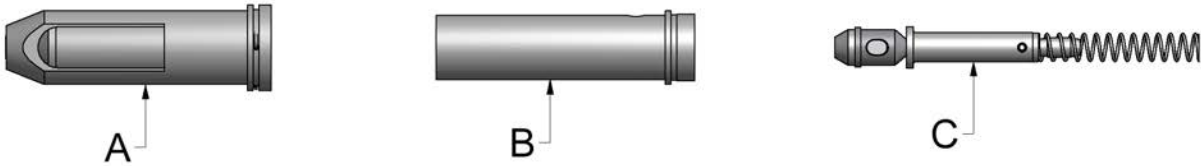

1. Remove knurled cap from front of riveter head.
2. Place jaw assembly (C) inside collet (B).
3. Insert spring end of jaw assembly into hole of head piston. Apply enough pressure to engage collet threads. Turn until collet bottoms on shoulder of piston and collet lock snaps into slot in piston. Hand tight is sufficient.

NOTE: To remove collet, push collet lock back into collet (using a blunt pointed tool) turning the collet clockwise.

4. Place sleeve assembly (A) over collet and head piston. Slip knurled cap over the sleeve assembly and hand tighten onto end of riveter head.

TOOL CAPACITY CHART:

The numbers shown in the rivet columns below are the maximum grip length that can be installed with this tool. Dashes indicate those rivets sizes which cannot be installed in any grip length.

Gage Bilt certifies the GB784 will install the fasteners listed below

GAGE BILT TOOL	STANDARD CHERRYLOCK® (NAS1398/99 & HS4464 & HS5413)							
	NOSE ASSEMBLY	RIVET DIAMETER	ALUMINUM		MONEL		STAINLESS	
			2163	2162	2563	2562	2643	2642
			UNIV. HEAD	CTSK. HEAD	UNIV. HEAD	CTSK. HEAD	UNIV. HEAD	CTSK. HEAD
GB784	XX-681-25	-4	ALL	ALL	ALL	ALL	ALL	ALL
		-5	8**	8**	8**	9**	8**	9**
		-6	8**	8**	8**	9**	8**	9**
		-8	8**	8**	8**	9**	-	-

GAGE BILT TOOL	BULBED CHERRYLOCK® (NAS1738/39)					
	NOSE ASSEMBLY	RIVET DIAMETER	ALUMINUM		MONEL	
			2239	2238	2539	2538
			UNIV. HEAD	CTSK. HEAD	UNIV. HEAD	CTSK. HEAD
GB784	XX-681-25	-4	ALL *	ALL *	ALL *	ALL *
		-5	ALL *	ALL *	ALL *	ALL *
		-6	ALL *	ALL *	ALL **	ALL **

*May require 95 PSI at tool.

**Indicates maximum grip



Grip Gage #269G3 (Similar to #269C3)

For CHERRYMAX® and CHERRYLOCK® rivets
(Sold Separately)

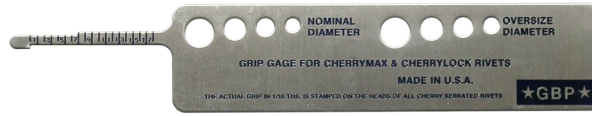

Fill Bottle #745263

(Sold Separately)



Air Bleeder Assy #704153

(Equivalent to #700A77)
(Sold Separately)

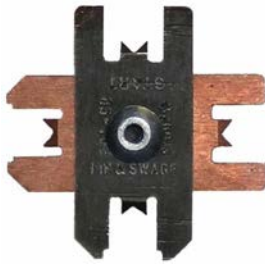

Gage Bilt also supplies pin & collar
swage inspection gages to certify correct
swage installation
(Sold Separately)

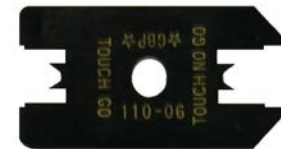

Alternative Styles

(Sold Separately)

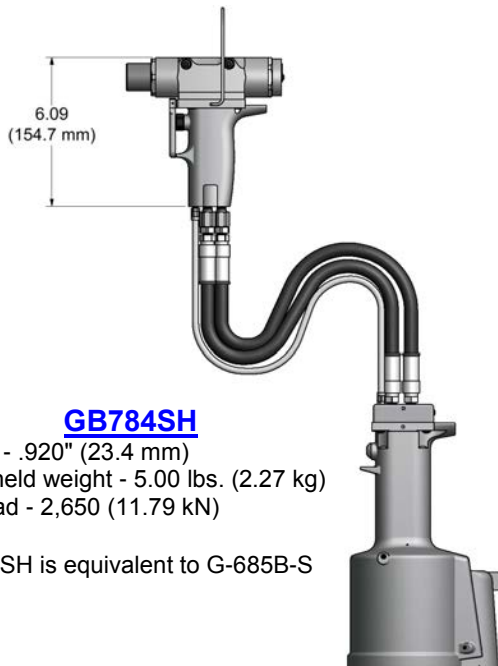

GB784SH

Stroke - .920" (23.4 mm)
Hand held weight - 5.00 lbs. (2.27 kg)
Pull load - 2,650 (11.79 kN)

GB784SH is equivalent to G-685B-S



GB784SR

Stroke - .920" (23.4 mm)
Hand held weight - 3.00 lbs. (1.36 kg)
Pull load - 2,650 (11.79 kN)



This page intentionally left blank

Riveter Kits Available

(Sold Separately)



Gage Bilt offers a wide selection of standard and custom kits tailored to your needs.
Contact us for more information.

GB784RK-1 Riveter Kit

(Equivalent to G784CLRB)



GB784RK Riveter Kit

(Equivalent to G784CLRA)



Stroke Setting Gage

#784159

Equivalent to (680A159)

Sets stroke on the GB784 installation tool.
(Sold Separately)

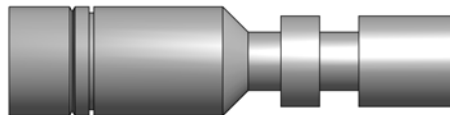

Adapter

#784740

Equivalent to (RVA84A / 680B57)

Adapts GB740 series nose assy's to
GB784 installation tool
(Sold Separately)



Adapter

#784704

Equivalent to (680B205)

Adapts 456MAX-749-35, 456MAX-704-54RA,
456MAX-704-40OS & 456MAX704-43OS series nose
assy's to GB784 installation tool
(Sold Separately)

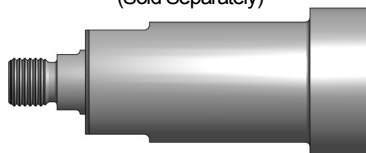

Adapter

#784715

Equivalent to (680B46)

Adapts GB715 series nose assy's to
GB784 installation tool
(Sold Separately)

